

Der vorliegende Band ist die zweite Ausgabe einer Dokumentation der Lehre und Forschung an der Fakultät für Architektur, Facility Management und Geoinformation sowie ein Rückblick auf 20 erfolgreiche Jahre kooperativen Lehrens und Lernens in der DIA, Deutschlands größtem englischsprachigem Masterstudiengang in Architektur. Die hier versammelten Texte und Studienarbeiten sind ein Spiegel aktueller gesellschaftlicher Entwicklungen, in denen nachhaltiges Planen, ökologische Umsicht und soziale Verantwortung im Einklang mit einer technologisch ambitionierten Herangehensweise stehen.

This book is the second in a series documenting the teaching and research carried out by the Faculty of Architecture, Facilities Management, and Spatial Information. It reviews the history of the Dessau Institute of Architecture, which offers Germany's largest English-language master's programme in architecture. The department has pursued a cooperative approach to teaching and learning over the last twenty years. The works collected here reflect current social developments, in which sustainable planning, environmental awareness, and social responsibility are in accord with an ambitious technological approach.



Hochschule Anhalt

Next to Bauhaus

2



**Dessauer
Schule**

Dessau School
of Architecture

Next
to Bauhaus

2

**Dessauer
Schule**
Dessau School
of Architecture

Hochschule Anhalt

Anhalt University of Applied Sciences

Das Jahrbuch ist die zweite Ausgabe einer
regelmäßigen Dokumentation der Lehre und
Forschung an der Fakultät für Architektur,
Facility Management und Geoinformation.

*This yearbook is to be counted as the
second edition of an annual documentation
of the teaching and research carried out
at the Faculty of Architecture, Facilities
Management and Geoinformation.*



Hochschule Anhalt

Anhalt University of Applied Sciences

Inhalt

Content

VORWORT Grußwort des Dekans Matthias Höhne	INTRODUCTION Letter from the Dean Matthias Höhne	9
RETROSPEKTIVE 20 JAHRE DIA	RETROSPECTIVE 20 YEARS DIA	
Kosmos DIA Ralf Niebergall	Cosmos DIA Ralf Niebergall	17
20 Jahre DIA Sandra Giegler	20 Years DIA Sandra Giegler	21
Das andere Ende des Bauhauses Johannes Kister	Another Focus of Bauhaus Johannes Kister	27
LEHRKONZEPTE AUS EINER HAND	PEDAGOGICAL CONCEPTS FROM A SINGLE SOURCE	
Was Forschung mit Intuition verbindet Alfred Jacoby	Architecture as Intuition or Research? Alfred Jacoby	33
Berufsvorbereitung für den Architekten Natascha Meuser	Professional Preparation for the Architect Natascha Meuser	41
COOP Design Research Stephan Pinkau	COOP Design Research Stephan Pinkau	50
PROJEKTE	STUDENT PROJECTS	
Masterstudiengang Bachelorstudiengang	Master Degree Programme Bachelor Degree Programme	64 179
MENSCHEN VOR UND HINTER DEN KULISSEN	PEOPLE ON STAGE AND BEHIND THE SCENES	
Vortragsreihe Dessauer Gespräche Johannes Kister	Lecture Series Dessau Talks Johannes Kister	217
Lehrwerkstatt Bauhaus 100 Sabine Thalmann	Bauhaus 100 Teaching Workshop Sabine Thalmann	219
Einrichtungen Institute Lehrende und Mitarbeitende Autoren und Akteure Next Generation	Facilities Institutes Faculty and Staff Authors and Contributors Next Generation	222 224 226 228 230

Grußwort des Dekans

Letter from
the Dean

Matthias Höhne



Foto: Sam Sanchez

Grußwort des Dekans

Matthias Höhne

Architektur wird in diesem Jahrbuch vor allem in opulenten Zeichnungen und Bildern gezeigt. Zusammen mit kurzen Texten werden Konzepte und Ideen von Entwürfen und Konstruktionen aus den vergangenen zwei Ausbildungsjahren vorgestellt.

Verführt von den optischen Reizen beim Betrachten verblasst zu schnell das eigentliche Ziel. Wir bilden aus, um Architektur zu bauen. Wie passen die schillernden Projekte mit utopischer oder dystopischer Anmutung, mit comichaften oder werbenahen Darstellungen und die Raumstrukturen jenseits physikalischer Gesetze zu diesem einfachen Ziel?

Das Studium muss die Grundlagen des fachlichen Wissens und des planerischen Handwerks vermitteln. Beginnend bei konstruktiven und statischen Kenntnissen, gehört auch das Verständnis der Bauphysik und des Baumanagements dazu. Den Kern unseres Berufs zeichnet die Verbindung dieser technischen Aspekte mit den gestalterischen Anforderungen aus. Unter Berücksichtigung von Material und Farbe formen wir Baukörper. Für diese Grundlagen unseres Handwerks stellt sich wie in vielen anderen Bereichen die Frage: **analog oder digital**, virtuell am PC oder mit den Händen geschaffen? Diese Frage stellt keinen Widerspruch dar, sondern demonstriert die breite Palette unserer Ausdrucksmöglichkeiten, die von der weichen Bleistiftskizze bis hin zum 3D-Modell reichen. Uns stehen heute Visualisierungsmöglichkeiten zur Verfügung, die wir vor 30 Jahren kaum erahnten oder erhofften. Dabei vereinfachen Computer nicht nur die Anschaulichkeit der dreidimensionalen Form. Simulationen oder Modellbetrachtungen umfassen ebenso das Tragwerk, das Hausklima und das Verarbeiten von Kenndaten und Statistiken unter anderem im Städtebau. Alle diese Verfahren erleichtern uns die Planung. Wenn wir die Betrachtung in dieser Breite zulassen und nicht vorschnell auf das visuell Reizvolle eingrenzen, sind wir mitten in der Aktualität der Lehre. Wie spiegelt sich unsere Zeit, wie spiegeln sich die gesellschaftlich emotionalisierenden

Letter from the Dean

This yearbook showcases architecture first and foremost in opulent drawings and pictures. Together with short texts, concepts and ideas of drafts and constructions from the last two years of training are presented in this bi-annual publication.

Seduced by the visual charms when looking at them, it is all too easy for the reader to overlook the actual objective. We train to build architecture. How do the dazzling projects with their utopian or dystopian impressions, their comic-like or almost promotional representations and the structures that defy the laws of physics fit with this simple objective?

A course of study must teach the basics of the specialist knowledge and the planning craft. Beginning with building and structural proficiency, it also includes the ability to understand construction physics and construction management. The core of our profession is characterised by the combination of these technical aspects with the creative requirements. Taking material and colour into consideration, we form building structures. For these basics of our craft, the question arises, as it does in many other areas: do we work in the analogue or the digital domain? Do we create virtually on the PC or manually with our hands? Rather than being a contradiction, this question demonstrates the broad palette of our expressive possibilities, ranging from soft pencil sketches all the way to 3D models. Today, we can avail of visualisation options which we could have scarcely imagined or hoped for 30 years ago. In the process, computers simplify not only the clarity of the three-dimensional form. Simulations or model views also include the supporting structure, the climate inside the building and the processing of characteristic and statistical data in, among others, urban development. All these methods make planning easier for us.

Allowing ourselves to take this type of broad view rather than hastily limiting ourselves to the visually appealing brings us to the heart of

what teaching is about these days. How is the current era reflected? How are the topics that emotionalise society reflected in the students' works? The general public discusses climate observations that extend 30 to 50 years into the future. Architects plan houses that will define our cities for the next 30 to 50 years or longer. How likely is it that our predictions will be relevant over these long time spans? The climate data of buildings, as measured during the first cold and hot periods after their completion, only confirm the simulations to a limited extent. Complying with directives is one thing, aligning our actions with the goal of minimising energy and raw material consumption is—obviously—quite another.

How enduring is the beauty of architecture? This question encapsulates two levels: a structural one and, likewise, a sensual one. The occurrence of structural damage relates to the structural area. The fact that façades become outdated does, however, raise the question of the durability of design. What are qualities that outlast time, fashions or changing doctrines? How soon will this yearbook's utopian or merely contemporary works appear old-fashioned and outdated?

Academic considerations and investigations about construction methods that will conserve material, resources and energy aim to provide answers to current social questions. Far less attention is paid to questions regarding the correct function and optimal quality of use. How do you organise a function in a room so that its usefulness endures? The fact that the size of a building determines a level of energy and raw material consumption and therefore a CO₂ equivalent is widely understood. Do we act on this knowledge? Do we respect this obvious correlation in the public debate as well as in the students' projects? In this context, we must not confuse the issue of appropriate scale with calls to forgo or make do. The issues at stake here is optimising the confluence of partially divergent interests and prioritising

Themen in den Arbeiten der Studierenden wider? Die Öffentlichkeit diskutiert **Klimabetrachtungen**, die in eine Zukunft von 30 bis 50 Jahren reichen. Architekten planen Häuser, die in den kommenden 30 bis 50 Jahren oder länger unsere Städte bestimmen werden. Mit welcher Wahrscheinlichkeit werden unsere Prognosen in diesen langen Zeiträumen zutreffen? Die Klimadaten von Gebäuden, gemessen in den ersten Kälte- und Hitzeperioden nach der Fertigstellung, bestätigen nur bedingt die Simulationen. Verordnungen einzuhalten ist eines, unser Handeln auf das Ziel der Minimierung von Energie- und Rohstoffverbrauch abzustimmen ist – offensichtlich – etwas anderes.

Wie beständig ist die **Schönheit von Architektur**? Diese Frage birgt zwei Ebenen: eine konstruktive und gleichermaßen eine sinnliche Ebene. Das Auftreten von Bauschäden betrifft den konstruktiven Bereich. Dass Fassaden unmodern werden, wirft jedoch die Frage nach der Dauerhaftigkeit von Gestaltung auf. Was sind Qualitäten, die die Zeit, die Moden oder den Wechsel von Theorien überdauern? Wie schnell werden die utopischen oder lediglich zeitgeistigen Arbeiten dieses Jahrbuchs gestrig und überholt erscheinen?

Überlegungen und Untersuchungen in der Lehre zum material-, ressourcen- und energiesparenden Bauen versuchen Antworten auf aktuelle gesellschaftliche Fragen zu geben. Weit weniger im Fokus stehen die Fragen nach der richtigen Funktion, der optimalen **Nutzungsqualität**. Wie wird eine Funktion dauerhaft sinnvoll im Raum organisiert? Dass mit der Größe eines Gebäudes über einen Energie- und Rohstoffverbrauch und damit über ein CO₂-Äquivalent entschieden wird, ist allgemein bekannt. Handeln wir nach diesem Wissen? Beachten wir in der öffentlichen Diskussion ebenso wie in den Projekten der Studierenden diesen offensichtlichen Zusammenhang? Dabei sollte man die Frage nach dem rechten Maß nicht mit der Forderung nach Verzicht

oder Suffizienz verwechseln. Es geht um ein Optimum des Zusammenführens teils divergierender Interessen und um Planungssorgfalt. Natürlich sind Wirtschaftlichkeits- beziehungsweise Effizienzbetrachtungen in der Architektur so alt wie das Bauen. Neu ist nur, dass wirtschaftliche und umweltschonende Ziele zusammengeführt werden. Gute Architektur ist im Grunde nachhaltig. Seit mehreren Jahrzehnten schon gibt es Ökobilanzen. Die Unmenge an Bauprodukten, an Produktionsverfahren und Möglichkeiten des Einbaus lässt sich zum Glück nicht in eine **Einsparverordnung des Materials** packen. Dies wäre nur eine weitere Simulation, die uns eigenes Nachdenken und verantwortliches Handeln abnimmt.

Es kommt auf den Entwurf an. Wie wird eine Idee, ein individuelles Konzept sinnvoll umgesetzt? Die Hoffnung besteht, dass wir gute Architektur nie berechnen oder ausrechnen können. In diesem Sinn bleiben alle Modellsimulationen Etappen auf dem Weg zum fertigen Haus. Der Architekt ist in der Lage, zwischen unterschiedlichen, sich zum Teil widersprechenden Anforderungen abzuwägen. Es bleibt die wunderbare Herausforderung, mit dem eigenen Nachdenken und dem eigenen Bauchgefühl die richtige Balance zwischen Rationalem und Emotionalem zu finden. Im unerklärlichen Teil guter Architektur steckt ein wesentlicher Grund für die Faszination unseres Berufs. Hier treffen sich diese im Technischen gestarteten Betrachtungen mit Jasper Cepl's Überlegungen zur Architekturlehre, veröffentlicht im Jahrbuch 1: »Was wir über Architektur wissen, das wissen wir aus Erfahrung und nicht aus Berechnung.« Dieser hier angesprochene wichtige Teil Erfahrung ist um Plausibilität, um Sinnfälligkeit der Entwurfsschritte zu erweitern. Es ist die Forderung an die Studierenden, selbstständig zu denken, das eigene Handeln zu reflektieren. Damit unsere umfassenden Bemühungen im Umweltschutz auch tatsächlich zum

diligent planning. Naturally, economic and/or efficiency considerations in architecture are as old as construction itself. The only new aspect is that economic and environmental targets are now being combined. In principle, good architecture is sustainable. Lifecycle assessments have been around for several decades. The sheer vastness of construction products, production methods and installation options luckily cannot be packaged into an efficiency decree for the material. This would only be yet another simulation, relieving us from thinking for ourselves and acting responsibly.

It all comes down to the design. How is an idea, an individual concept appropriately realised? Hope remains that we can never compute or calculate good architecture. With this in mind, all model simulations are merely stages on the journey to the finished house. The architect is able to weigh up different, sometimes contradictory requirements. The wonderful challenge remains, of using our own thoughts and gut feelings to strike the right balance between the rational and the emotional. The inexplicable aspect of good architecture is an important reason for the fascination of our profession. This is where these observations born out of the technical fields meet with Jasper Cepl's reflections on the teaching of architecture, published in yearbook 1: "What we know about architecture we know from experience and not from computations." This important aspect experience addressed here must be expanded to include plausibility, by the obviousness of the design steps. It is the call to the students to think for themselves, to reflect their own actions. To ensure that our comprehensive efforts for environmental protection actually lead to the goal, they should be able to withstand simple plausibility checks. Many of the beautiful old houses fail to meet our high building standards, but they are still sustainable in the truest sense of the word. Whether our current "sustainable architecture" will truly endure will be left,

at the earliest, for the coming generations to find out. The best works from the previous terms reflect the aspects addressed here in very different, sometimes controversial ways. Hopefully, the joy of teaching and learning invested in the works will transfer to the reader of this yearbook while browsing, looking, recognising and understanding.

Ziel führen, sollten sie einfachen Überprüfungen auf Plausibilität standhalten. Viele der schönen alten Häuser entsprechen nicht unseren hohen Baustandards, trotzdem sind sie im besten Sinn nachhaltig. Ob unsere aktuelle »nachhaltige Architektur« tatsächlich dauerhaft Bestand hat, wird frühestens die kommende Generation wissen.

Die besten Arbeiten aus den vergangenen Semestern reflektieren auf sehr unterschiedliche, teils kontroverse Weise die hier angesprochenen Aspekte. Hoffentlich überträgt sich die Freude am Lehren und am Lernen, die in den Arbeiten steckt, auf den Leser dieses Jahrbuchs – beim Blättern, Betrachten, Erkennen und Verstehen.



Via Cordusio in Mailand. »Die Sinnlichkeit einer Skizze, das Nachvollziehen der Stadtplanung mit dem Stift oder einfach die Freude am Zeichnen – was kann es ersetzen?«
Skizze: Matthias Höhne

Einführung

In seinem Grußwort plädiert Dekan Matthias Höhne für eine Ausbildung, die als Spiegel aktueller gesellschaftlicher Entwicklungen zum eigenständigen Arbeiten und Forschen anregt. Sie soll die Studierenden befähigen, Architektur von beständiger Schönheit mit optimaler Nutzungsqualität zu schaffen, jenseits aller zeitgeistigen Modeerscheinungen. Nachhaltiges Planen, ökologische Umsicht und soziale Verantwortung im Einklang mit einer technologisch ambitionierten Herangehensweise – diese Themen stehen im Zentrum des Masterstudiengangs Architektur an der Hochschule Anhalt. Ralf Niebergall zeigt, dass die mitteldeutsche Provinz ein optimaler Nährboden für kosmopolitische Weltläufigkeit sein kann, wenn wie in der *Dessau International Architecture Graduate School (DIA)* Studierende verschiedenster kultureller und sozialer Hintergründe mit einer gemeinsamen Leidenschaft, der Architektur, zusammenkommen und so im Lokalen ein komplettes Universum formen. Sandra Giegler blickt auf 20 erfolgreiche Jahre kooperativen Lehrens und Lernens in der DIA, Deutschlands größtem englischsprachigem Masterstudiengang in Architektur, zurück. Dass diese einzigartige Architekturschule mit ihrem explizit auf Internationalität und Diversität ausgerichteten Lehrprofil eine Vorreiterrolle für ganz Deutschland innehat, betont Johannes Kister. Vorgestellt werden darüber hinaus drei an der Hochschule Anhalt vertretene Lehrkonzepte. Alfred Jacoby befürwortet das Zusammenwirken von Forschung und Intuition in sämtlichen Gestaltungsdisziplinen: Eine intuitive Idee erhält durch den Prozess der gedanklichen Annäherung eine letztlich greifbare Form. Natascha Meuser sucht die Vision einer interdisziplinären Lehre, die den Menschen im Blick hat. Im Sinne eines ganzheitlichen Ansatzes sind die eigenen Fächergrenzen zu überwinden, um neue Blickwinkel zu ermöglichen. Stephan Pinkau stellt das von der Hochschule Anhalt und der *Stiftung Bauhaus Dessau* in Kooperation mit der Humboldt-Universität zu Berlin durchgeführte Masterprogramm COOP Design Research vor, das sich an praktizierende Gestalter richtet.

Introduction

In his welcoming address, Matthias Höhne advocates an education encouraging independent working and researching as a mirror of current social trends. It should empower students to create architecture of enduring, sustainable beauty with optimal usage quality—that goes beyond any contemporary fads. Ralf Niebergall shows that Dessau can be the ideal hotbed for cosmopolitanism—if, as is the case at the *Dessau International Architecture Graduate School (DIA)*, students from a wide variety of cultural and social backgrounds with a shared passion, architecture, come together to locally form a complete universe. Sandra Giegler has a track record of 20 years of collaborative teaching and learning at DIA, Germany's largest English language master's course in architecture, which was celebrated in October 2019 with a star-studded convention. The fact that this unique school of architecture, with its teaching profile explicitly geared towards internationality and diversity, plays a pioneering role for the whole of Germany, is emphasised by Johannes Kister. It also introduces three different teaching concepts represented at the Anhalt University of Applied Sciences. Alfred Jacoby supports the collaboration, the collage, of research and intuition across all the design disciplines: Through the process of intellectual approximation, an intuitive idea is ultimately given a tangible form. Natascha Meuser seeks the vision of interdisciplinary teaching with a focus on people. As part of a holistic approach, one must overcome the boundaries of one's own discipline in order to depart from beaten paths and to open up new perspectives. Stephan Pinkau introduces the COOP Design Research master's programme for practising designers. This course is run by the Anhalt University of Applied Sciences and the *Bauhaus Dessau Foundation* in collaboration with the Humboldt University of Berlin.

Internationale Kooperationen International Cooperations

Auswahl | Selection



University of Liverpool, GB



Alma Mater Studiorum
Università di Bologna, IT



Bezalel Academy of Arts and
Design Jerusalem, IL



Università luav di Venezia, IT



University of Limerick, IR



California Polytechnic
State University, US



HTW Chur, Hochschule für
Technik, CH



The University of Kansas, US



Università Degli Studi Di
Sassari, IT



Universidad de Palermo, UP |
Buenos Aires, Argentina, AR



Universidad ORT
Uruguay, UY



Moscow Architectural Institute
(State Academy) – MArch, RU



Universidad de Buenos Aires,
BR



University of Kentucky, US



École Nationale Supérieure
d'architecture Nantes, FR



Lodz University of
Technology, PL



École Spéciale
d'Architecture, FR



National Technical University of
Ukraine, UA



The College of Management
Academic Studies (Comas), IL



Universidade Federal de Ouro
Preto, BR



Moholy-Nagy-Universität für
Kunsthandwerk und Gestaltung, HU



Politecnico di Milano, IT



Universität Liechtenstein, LI



Saints Cyril and Methodius
University of Skopje, MK



Taylor's University (Taylor's
Lakeside Campus), MY

Retrospektive 20 Jahre DIA Retrospective 20 Years DIA

Sandra Giegler
Johannes Kister
Ralf Niebergall



KOSMOS DIA

Ralf Niebergall

Es gibt wohl kaum einen anderen Ort in Deutschland, wo auf so kleinem Raum junge Menschen aus allen Gegenden unseres Planeten zusammentreffen, wie auf den wenigen Hundert Metern zwischen dem Bahnhof und dem Bauhaus Dessau. Und anders als in den großen Metropolen, wo man sich zwar begegnet, aber nicht unbedingt in Beziehung zueinander treten muss, bildet sich hier ganz zwangsläufig eine Art Weltgemeinschaft. Und die jungen Menschen teilen eine Leidenschaft: die Architektur! So mannigfaltig die Sprachen und Hautfarben der Studierenden sind, so vielfältig sind auch ihre Erfahrungen, ihre Lebenswirklichkeiten und ihre Vorstellungen und Träume von einer Architektur des 21. Jahrhunderts.

Dem kosmopolitischen Bauhaus und der klassischen Moderne gelang es, vielleicht sogar unbeabsichtigt, zu einem weltumspannenden Phänomen in Stadtplanung, Architektur und Design zu werden. Ist dies auch in unserer Zeit erstrebenswert? Wer heute am gleichen historischen Ort eine globale Community in Architektur zu bilden beansprucht, muss sich täglich dieser Frage stellen. Ohne Zweifel: Technologien, Kommunikations-, Produktions- und Warenströme sind längst nur noch im Weltmaßstab zu denken; genauso wie die existenziellen Probleme, die wir zu lösen haben. So entwickelte ein Student der DIA eine Software, mit deren Hilfe Planerinnen und Planer in Dessau und in Singapur interaktiv und in Echtzeit am gleichen städtebaulichen Modell arbeiten, per Handbewegung Volumina hin und her schieben, sie dicker oder höher machen können. Künstliche Intelligenz, mit den richtigen Parametern gefüttert, unterbreitet uns unzählige Optimierungsvorschläge für Formen, Konstruktionen, die Organisation von Grundrissen – wir müssen nur noch wählen. Aber was sind die richtigen Parameter und wodurch wird unsere Auswahl oder die Entscheidung über dicker oder höher bestimmt? Das führt

Cosmos DIA

There is probably hardly another place in Germany where in such a small space, young people from all the regions of our planet meet, as on the few hundred metres between the railway station and Bauhaus Dessau. And unlike in big cities, where one encounters other people but does not necessarily have to interact with them, a kind of global community is quite inevitably formed here. And the young people share a passion: architecture! The diversity of the languages and skin colours of the students is matched by their multifaceted experiences, realities of life and ideas and dreams of architecture for the 21st century. The cosmopolitan Bauhaus movement and classical modernity succeeded, maybe even inadvertently, in becoming a worldwide phenomenon in urban planning, architecture and design. Is this also desirable in our times? Those who set out to create a global community in architecture at the same historic location must ask themselves this question every day. Without doubt: technologies, flows of communication, production and goods, have long since only been imaginable on a global scale. The same is true of the existential problems that we must solve. For example, a student at the DIA developed a software program for planners in Dessau and Singapore, which enables them to work interactively and in real time on the same urban development model, to move volumes to and fro, make them thicker or higher, all with the movement of a hand. Artificial intelligence, when fed the right parameters, proposes countless suggestions for optimising shapes, constructions, floor plan management—all we need to do is choose. But what are the right parameters? What determines our choice or a decision to go thicker or higher? This leads us straight to the heart of the discourse about the nature of architecture.

If we regard it as a resonance space for interpersonal relationships, behaviours, trends in society and the manifestation of shared cultural values, the questions go far beyond form finding and technology. The answers can still be found in useful, technically obvious and, in the best case, beautiful appearance—if it is to become architecture. Vitruv's universal truth is constantly subjected to field tests. As multifaceted as our education is—we will never succeed in fully capturing its complexity in coherent teaching. But we can attempt approximations. For a university located at the heart of Europe, the city as a place of social discourse is an important anchoring point. Admittedly, in an era when Facebook, Google, global economic cycles and financial flows with their impenetrable laws seem to determine our realities of life more than the place where we live, the city has been declared dead many times over. However, we are experiencing a counter-movement: Citizens are taking the fate of their towns and cities into their own hands, forming communities to organise socially balanced living, and to reconcile the conflicting priorities of working and living. They are reoccupying the public space, seeking neighbourhood, they want to design their living space along more ecological lines, for instance, with urban gardening, rooftop beehives or other ideas about mobility and energy supply. And they are politically engaged, something that the powers that be do not always appreciate. Such changes must be accompanied by architects, but maybe in a different way than the one conveyed by the traditional professional profile. People who look and listen closely, analyse economic and social relationships, who seek allies for change. People who do not consider it beneath them to use their wealth of ideas to solve seemingly trivial problems and create something architecturally unique. People whose vision it is not to bemoan climate change and social distortions as a God-given scourge but who see it as an incentive

uns mitten hinein in den Diskurs über das Wesen der Architektur. Wenn wir sie als Resonanzraum für zwischenmenschliche Beziehungen, Verhaltensweisen, gesellschaftliche Entwicklungen und für die Ausprägung gemeinsamer kultureller Werte sehen, gehen die Fragestellungen weit über Formfindung und Technologie hinaus. Die Antworten darauf finden sich nach wie vor in nützlicher, technisch sinnfälliger und im besten Falle schöner Gestalt – wenn es Architektur werden soll.

Vitruvs universelle Wahrheit ist dem ständigen Praxistest unterworfen. So facettenreich unsere Ausbildung ist – es wird uns nie gelingen, ihre Komplexität vollständig in eine kohärente Lehre zu fassen. Aber wir können Annäherungen versuchen. Für eine Hochschule mitten in Europa ist die Stadt als Ort des gesellschaftlichen Diskurses ein wichtiger Ankerpunkt. Freilich: In Zeiten, in denen Facebook, Google, globale Wirtschaftskreisläufe und Finanzströme mit ihren undurchschaubaren Gesetzen unsere Lebenswirklichkeit mehr zu bestimmen scheinen als der Ort, an dem wir leben, wurde die Stadt schon mehrmals totgesagt. Aber wir erleben eine Gegenbewegung: Bürger nehmen das Schicksal ihrer Städte selbst in die Hand, bilden Gemeinschaften, um sozial ausgewogenes Wohnen zu organisieren, Arbeit und Leben miteinander zu versöhnen. Sie eignen sich den öffentlichen Raum neu an, suchen Nachbarschaft, wollen ihren Lebensraum ökologischer gestalten: etwa mit Urban Gardening, dem Bienenstock auf dem Dach oder mit anderen Ideen zu Mobilität und Energieversorgung. Und sie mischen sich politisch ein, was Herrschenden nicht immer gefällt.

Solche Veränderungen brauchen die Begleitung von Architektinnen und Architekten, aber vielleicht in einer anderen Art und Weise, als es das tradierte Berufsbild vermittelt. Menschen, die genau hinschauen und hinhören, ökonomische und soziale Beziehungen analysieren, Verbündete

suchen für Veränderung. Menschen, die sich nicht zu schade sind, mit ihrem Ideenreichtum auch scheinbar banale Probleme zu lösen und selbst damit architektonisch Einmaliges schaffen. Menschen, deren Vision es ist, Klimawandel und soziale Verwerfungen nicht als gottgegebene Geißel zu beklagen, sondern als Ansporn zu sehen, um Kreativität zu entfalten ohne die Hybris, allein die Welt retten zu können. Diese Haltung auszuprägen, ist Dessau der ideale Ort.

Studierende aus reichen Regionen treffen hier auf Kommilitonen, deren Herkunftsländer die Folgen unserer Verschwendung und Achtlosigkeit erleiden müssen, selbstbewusste junge Leute aus boomenden Metropolen auf andere, deren Heimat ausblutet, weil die Jugend aus Hoffnungslosigkeit davonläuft. Dennoch bildet sich eine enge Gemeinschaft, weil Empathie und das Einanderzuhören spielerisch erlernt werden: bei Potluck Dinners oder bei der Vorbereitung von ausgelassenen Partys in der an Zerstreuungen nicht eben reichen mitteldeutschen Provinz. Eine Kulturtechnik der Lebensfreude, die schon das Bauhaus meisterhaft zelebrierte. Zugleich ist die Mission eine höchst ernsthafte.

Es wäre vermessen, von Deutschland aus eine Architektur für die Welt kreieren zu wollen. Richtige Antworten auf die drängenden globalen Fragen unserer Zeit sind immer lokal, gebunden an den Ort mit seiner spezifischen Vergangenheit und Zukunft, seinen Verletzungen, Widersprüchen, Begrenzungen, aber auch Hoffnungen und Träumen. Die gelegentlich belächelte oder gar verhasste deutsche Präzision und Nüchternheit kann jedoch helfen, sowohl universelle Fragen auf den »lokalen« Punkt zu bringen, als auch Lösungen zu entwickeln, die alle technischen Möglichkeiten unserer Zeit nutzen, ohne sie als Selbstzweck zu verstehen, sondern vielmehr als möglichst präzise eingesetzte Mittel, unser aller Kosmos ein wenig lebenswerter, angstfreier, zukunftsfähiger, schöner zu gestalten.

to unleash creativity without the hubris of single-handedly saving the world. And Dessau is the ideal place to develop this attitude. Students from wealthy regions meet ones whose countries of origin have to suffer the consequences of our wastefulness and mindlessness; self-confident young people from booming metropolises meet others whose home is bleeding dry because the next generation is fleeing in desperation. Nevertheless, a closely-knit community forms because empathy and listening to each other are learned playfully—at pot-luck dinners or when jolly parties are held in the Central German province not necessarily known for its diversions. A cultural technology of vitality, previously masterfully celebrated by Bauhaus. At the same time, the mission is a very serious one. It would be presumptuous to want to create architecture for the world from Germany. The right answers to the pressing global questions of our time are always local in nature, tied to the place with its specific past and future, its injuries, contradictions, limitations, but also hopes and dreams. The occasionally belittled or even hated German precision and sobriety may, however, help to bring universal questions to the “local” point and to develop solutions that leverage all the technical possibilities of our time without seeing them as an end in itself but rather as a means to be applied as precisely as possible to make our shared cosmos a little more liveable, less fearful, more future-ready and more beautiful.



20 Jahre DIA

Sandra Giegler

Die *Dessau International Architecture Graduate School* (DIA) ist Teil des Fachbereichs Architektur, Facility Management und Geoinformation der Fachhochschule Anhalt. Sie teilt sich in unmittelbarer Nähe zum weltberühmten Dessauer Bauhausgebäude von Walter Gropius den Campus mit dem Fachbereich Gestaltung. Die DIA bietet nicht nur die einzigartige Möglichkeit, im Umfeld eines architektonischen Weltkulturerbes zu studieren, sondern orientiert sich auch an von Walter Gropius und seinen Lehrkräften entwickelten Bildungskonzepten.

Mit zehn eingeschriebenen Studierenden startete die DIA 1999 ihr zweijähriges Masterprogramm. Eingerichtet worden war es als Reaktion auf den Bologna-Prozess, der es sich zur Aufgabe gemacht hatte, vergleichbare europäische Standards in der Hochschulbildung zu etablieren. Der Vollzeitkurs umfasst 120 Credits. Der Unterricht ist praxisnah, interkulturell und interdisziplinär konzipiert. Unterrichtssprache ist Englisch. Der Studiengang schließt mit einem international anerkannten Master of Arts ab und ist vom ASIIN akkreditiert.

Mit aktuell 100 eingeschriebenen Studierenden pro Jahr, die aus meist 300 Bewerbungen ausgewählt werden, ist die DIA heute Deutschlands größter englischsprachiger Masterstudiengang in Architektur. Trotzdem gewähren kleine Gruppen in den Kursen und Seminaren ein intensives, individuelles und produktives Lehr-, Lern- und Arbeitsumfeld. Den Studierenden soll hiermit die Gelegenheit gegeben werden, auf der Grundlage einer kritischen Auseinandersetzung mit dem Fach ihren eigenen Weg zu finden. In den vergangenen 20 Jahren haben so mehr als 1.500 Studierende aus über 50 Ländern das Programm absolviert und die hier erworbenen Kompetenzen und Ideen in der ganzen Welt verbreitet.

20 Years DIA

Dessau International Architecture Graduate School (DIA) is part of the faculty of architecture, facility management and geoinformation at the Anhalt University of Applied Sciences. In the immediate vicinity of the world-famous Dessau Bauhaus building by Walter Gropius, it shares its campus with the design faculty. DIA not only offers the unique possibility to study in the surroundings of an architectural world heritage but is also geared to the educational concepts developed by Walter Gropius and his lecturers.

With ten enrolled students, DIA started its 2-year master's programme in 1999. It was established as a response to the Bologna process, which made establishing comparable European standards in tertiary education its business. The full-time course consists of 120 credits. The lectures have been designed to be hands-on, intercultural and interdisciplinary and are held in English. The course completes with an internationally recognised Master of Arts accredited by ASIIN.

With currently 100 students enrolled per year, chosen from a usual pool of 300 applications, DIA is currently Germany's largest English language master's course in architecture. Nonetheless, small groups in the courses and seminars ensure an intense, personal and productive teaching, learning and working environment. It is aimed at giving students the opportunity to find their own way, based on a discerning examination of their subject. Over the past 20 years, more than 1,500 students from about 50 countries have completed the programme and spread the skills and ideas acquired here all around the world.



Students with a bachelor's degree are eligible for the master's course in architecture. The master's course completes the bachelor's course in architecture by systematically consolidating the fields of architecture and urban planning. The curriculum covers the subjects of design, history, theory and criticism, urbanism, computing, logic and representation, with the students able to set priorities according to their own needs. The aim is to promote an understanding of architecture as a social, cultural, political and economic activity closely linked to present problems and challenges. One focus of the course is therefore on analysing topical issues of cultural and social sciences as well as humanities. In addition, the latest findings from research and development, new methods, technologies and materials are taught. This is contrasted and historically contextualised by insights into the historic development of architecture and urban planning. The architectural education completed with a successful graduation then meets all the formal requirements to apply for membership of the architectural association.

Architecture in dialogue

With the chronological concurrence of no less than two anniversaries—20 years of Dessau International Architecture Graduate School as well as 100 years of Bauhaus—we had special reason for celebration in 2019. The DIA standpoints and viewpoints acquired in now 20 years of collaborative teaching and learning promised a productive conference at the end of 2019 so that the Anhalt University of

Zugangsvoraussetzung für den Master-Studiengang Architektur ist der Bachelor-Abschluss. Der Master-Studiengang komplettiert den Bachelor-Studiengang Architektur in Form einer systematischen Vertiefung der Bereiche Architektur und Stadtplanung. Der Lehrplan umfasst die Fächer Design, Geschichte, Theorie und Kritik, Urbanismus, Computing, Logik und Repräsentation, wobei die Studierenden nach eigenen Bedürfnissen Schwerpunkte setzen können. Gefördert werden soll das Verständnis von Architektur als einer sozialen, kulturellen, politischen und wirtschaftlichen Aktivität, die eng mit den Problemstellungen und Herausforderungen der Gegenwart verknüpft ist. Ein Schwerpunkt im Studiengang liegt deshalb in der Analyse aktueller Fragen der Kultur- und Sozialwissenschaften sowie der Geisteswissenschaften. Darüber hinaus werden die neuesten Erkenntnisse aus Forschung und Entwicklung, neue Verfahren, Technologien und Materialien vermittelt. Kontrastiert und in den geschichtlichen Kontext gesetzt wird dies, indem auch Einblicke in die historische Entwicklung der Architektur und Stadtplanung vermittelt werden. Die bei erfolgreich absolviertem Studiengang dann abgeschlossene Architekturausbildung erfüllt alle formalen Voraussetzungen, um die Mitgliedschaft in der Architektenkammer zu beantragen.

Architektur im Dialog

Das zeitliche Zusammenfallen gleich zweier Jubiläen, 20 Jahre *Dessau International Architecture Graduate School* sowie 100 Jahre Bauhaus, haben 2019 besonderen Grund zum Feiern gegeben. Die in nunmehr 20 Jahren kooperativen

Lehrens und Lernens gewonnenen Standpunkte und Perspektiven der DIA versprachen eine ertragreiche Konferenz am Ende des Jahres 2019, so dass die Hochschule Anhalt vom 23. bis 25. Oktober dazu einlud, die »Architektur im DIALOG« als globalisierte Disziplin im Hinblick auf das kooperative Lehr- und Lernfeld, das die DIA bietet, zu betrachten und zu überdenken. Studierende, Alumni, Lehrer und Experten erörterten in der Bauhaus-Aula aus verschiedenen Perspektiven Kernfragen der Architektur, unter anderem in drei Podiumsdiskussionen. Dass das Spannungsfeld von **Erhaltung und Modernisierung** nicht nur im komplexen Kontext des Bauhauses selbst ein immer aktuelles Thema ist, sondern generell auch in der zeitgenössischen Berufspraxis, diskutierten unter der Moderation von Nicolaus Schafhausen Roger Bundschuh, Johannes Kister, Daniela Spiegel und Vasco Pinheiro. Über die Frage **Forschung oder Intuition?** tauschten sich Dulmini Perera, Eric Helter, Sina Mostafavi und Laurent Lescop aus, moderiert von Alfred Jacoby. **Kultur oder Geld?** hieß das Thema, das Johanna Meyer-Grohbrügge, Ivan Cucina, Ralf Niebergall und Joanne Pascal mit Moderator Attilio Terragni besprachen. Und der Konflikt zwischen **Natur und Mensch**, wie er sich etwa im Konzept des Anthropozäns und in der Diskussion über den Klimawandel widerspiegelt, wurde bei der von Rainer Hehl moderierten Podiumsdiskussion von Ivan Haiman, Hamed Khalidi, Ilka Preschel, Janishka Shah, Anjali Ramachandran, Arpi Mangasaryan, Arturo Varela, Yang Lu und Ulises Peinado in den Blick genommen. **Die Konzeption und Organisation der Konferenz fand unter der Leitung von Johannes Kalvelage statt.**

Applied Sciences issued invitations for 23 to 25 October to observe and think about “architecture in dialogue” as a globalised discipline in terms of the collaborative teaching and learning environment offered by DIA. In the Bauhaus assembly hall, students, alumni, educators and experts discussed core architectural issues from different perspectives in a variety of settings that included three panel discussions. The fact that the conflicting priorities of conservation and modernisation is always a topical subject—not only in the complex context of Bauhaus itself but generally also in contemporary professional practice, was discussed by Roger Bundschuh, Johannes Kister, Daniela Spiegel, and Vasco Pinheiro, with Nicolaus Schafhausen as moderating host. Views on the question of “Research or intuition?” were exchanged by Dulmini Perera, Eric Helter, Sina Mostafavi and Laurent Lescop, hosted by Alfred Jacoby. “Culture or money?” was the topic that Johanna Meyer-Grohbrügge, Ivan Cucina, Ralf Niebergall and Joanne Pascal talked about with host, Attilio Terragni. And the conflict between nature and nurture, as it is reflected in the concept of the Anthropocene and in the discussion about climate change, for example, was examined in a panel discussion with Ivan Haiman, Hamed Khalidi, Ilka Preschel, Janishka Shah, Anjali Ramachandran, Arpi Mangasaryan, Arturo Varela, Yang Lu and Ulises Peinado, hosted by Rainer Hehl.

The conference was conceived and organised under the leadership of Johannes Kalvelage.



preservation or modernisation?



Studierende, Alumni, Lehrer und Experten erörtern Kernfragen der Architektur, unter anderem in drei Podiumsdiskussionen. Fotos: Aileen Dianne Krause



asphalt or jungle?



research or intuition?



culture or cash?



Studio Johannes Kister,
Präsentation des Projekts »Canale Grande« in Oberschöneweide.
Foto: Cornelia Böttner

Das andere Ende des Bauhauses

Johannes Kister

Das erste große Thema der DIA war die Stadt. Die Stadt als ein komplexes Gebilde, als der Gegenstand einer entwerflichen Recherche – und das meinte nicht nur die europäische Stadt. Von Anfang an haben sowohl Lehrbeauftragte und Gastprofessoren als auch die internationalen Studierenden globale Themen eingebracht.

Für mich als Architekt, der neben der Lehre auch baut, ist der städtebauliche Entwurfsparameter, das städtebauliche Argument, vor allem anderen der entscheidendste Parameter des Entwerfens. Das ist die Einsicht aus vielen Jahren Erfahrung und einer Vielzahl an Wettbewerbsteilnahmen. Das städtebauliche Argument qualifiziert einen Entwurf in seinen fünf Dimensionen. Drei kennen wir, die vierte ist die soziale, die fünfte die kulturelle Dimension. Die Körperhaftigkeit ist nicht das Ende eines Prozesses, sie steht vielmehr am Anfang und beinhaltet schon alle fünf Dimensionen durch die Setzung und das proportionale Verhältnis zur Umgebung. Hinter dieser Haltung verbirgt sich ein Paradigmenwechsel, der einen Gegensatz zur klassischen Moderne bedeutet und eine Abkehr von dem in diesem Jubiläumsjahr gefeierten Bauhaus darstellt, weil das städtebauliche Argument Ort, Zeit, Funktion und Typologie situativ sortiert, hierarchisiert und konkretisiert.

Die DIA hat in den vergangenen Jahren nach neuen Wegen in der Planung gesucht. Natürlich spiegelte sich in dieser Zeit auch das parametrische Entwerfen hier an der Schule wider, vor allem als Formfindung. Teilaspekte einer Aufgabe sind als Parameter vorgegeben, die im Programm dann Form generieren oder diese begründen sollen. Das Vorbild und der Vergleich mit der industriellen Produktion verleitete zu einem parametrisierten, computerbasierten Entwerfen, vernetzt mit digitalen Werkzeugen. Ein Diskurs, der sich immer neu belebt, zurzeit angefeuert durch die Wohnungsfrage. Es verbindet sich damit eine Hoffnung auf Rettung durch Serien

Another Focus of Bauhaus

DIA's first major topic was the city. The city as a complex structure, as an object of design research—and not only the European city. From the outset, lecturers and visiting professors as well as the international students introduced global topics. For me as an architect actively involved in building alongside my teaching work, urban development design parameters, the urban development argument, is the most decisive design parameter above all else. That is my finding from many years of experience and participating in a multitude of competitions. The urban development argument qualifies a design in its five dimensions. Three dimensions we know, the fourth one is the social, and the fifth one the cultural dimension. Physicality is not the end of a process—rather, it is the beginning and already contains all the five dimensions due to its implementation and its proportional relationship with its surroundings. This attitude conceals a paradigm shift, representing a contrast with classical modernity and a departure from the Bauhaus approach celebrated in this anniversary year. This is because the urban development argument sorts place, time, function and typology by situation and then hierarchically organises and substantiates them. In the past few years, DIA has been seeking new directions in planning. Naturally, parametric designing was also reflected here at the school during this period, mainly as form finding. Partial aspects of a task are specified as parameters that are then to generate form in the program or justify it. The role model and comparison with industrial production tempted one to parametrised, computer-based designing in connection with digital tools. This is a discourse that is continuously revived, and is currently spurred on by the housing question. It is coupled with the hope

of salvation through series and modules from digital production. One can see this as a remake of a Bauhaus idea, which involves reconciling design and industry. The continuation of an old idea by other means. This, however, did not turn out to be “the” answer to questions relating to authentic construction. The discourse with the city means something fundamentally different because architecture must be understood as a cultural discipline, a cultural technology that reaches far beyond functional and technical domains. And this attitude is particularly well nurtured at DIA. At the moment, we are experiencing a discourse about “decolonising”—and not only in connection with the reconstruction of Berlin’s Humboldt-Forum. It is about the perspective of science, of the humanities from Europe and North America relation to what is referred to as the rest of the world because everything that reputedly counts, that represents the unspoken benchmark, is developed in this dominant cultural domain. This is perspective that represents a global scale of values extending all the way to human rights. We must concede that this is an as yet unquestioned basic direction that has determined the law, ethics but also aesthetic leadership. It is currently put up for discussion not only for ethical reasons but also with regard to climate protection. This benchmark for measuring the world will be recalibrated. “Decolonising” is the vehement demand of new synchronicities in the sciences. Consequently, we must admit that the “international” style as a European and North American project is as much part of the colonising strategies of modernity as modernity itself. Architecture is an art discipline that—unlike art itself—needs the place, the city, the reference. Architecture is not transportable. It is determined by place and space. Architecture is a cultural technology that has been developing a polycentral view of construction for many years and has thus gained an advantage over other cultural technologies.

und Module aus digitaler Produktion. Man kann darin die Neuauflage einer Bauhausidee sehen, Design und Industrie miteinander zu versöhnen. Die Fortführung einer alten Idee mit anderen Mitteln. Das aber hat sich nicht als »die« Antwort auf Fragen des authentischen Bauens erwiesen. Der Diskurs mit der Stadt meint etwas grundsätzlich anderes, weil Architektur als eine kulturelle Disziplin, als eine Kulturtechnik zu begreifen ist, die weit über den funktionalen technischen Raum hinausgreift. Und diese Haltung ist an der DIA besonders gut aufgehoben.

Zurzeit erleben wir – und das nicht nur im Zusammenhang mit dem Neubau des Humboldt-Forums in Berlin – einen Diskurs zum Thema »Decolonizing«. Es geht dabei um die Frage der Perspektive der Wissenschaft, der Geisteswissenschaft aus Europa und Nordamerika auf die sogenannte restliche Welt; denn es ist so, dass alles, was vermeintlich zählt, was der unausgesprochene Maßstab ist, in diesem dominanten Kulturraum entwickelt wird. Eine Perspektive, die bis hin zu den Menschenrechten eine globale Werteskala darstellt. Wir müssen zugeben, dass dies eine bislang nicht in Frage gestellte Grundrichtung ist, die Recht, Ethik, aber auch ästhetische Führerschaft bestimmt hat. Aktuell zur Diskussion gestellt wird sie nicht nur aus ethischen Gründen, sondern auch hinsichtlich des Klimaschutzes. Dieser Maßstab, an dem die Welt gemessen wird, wird neu kalibriert werden. »Decolonizing« ist die vehemente Einforderung von neuen Gleichzeitigkeiten in den Wissenschaften. So müssen wir uns eingestehen, dass der »internationale« Stil als europäisches und nordamerikanisches Projekt genauso zu den *colonizing*-Strategien der Moderne gehört wie die Moderne selbst.

Architektur ist eine Kunstdisziplin, die – anders als die Kunst an sich – den Ort, die Stadt, den Bezug braucht. Architektur ist nicht transportabel. Sie wird bestimmt vom Ort und vom Raum. Architektur ist eine Kulturtechnik, die schon seit vielen Jahren einen polyzentralen Blick auf das Bauen entwickelt und damit einen Vorsprung vor anderen Kulturtechniken gewonnen hat. Davon zeugen nicht zuletzt

die Biennalen der vergangenen Jahre. Architektur ist das primäre Medium, in dem eine Gesellschaft sich selbst findet oder sich ihrer selbst vergewissert.

Es gibt kein Interesse an einem »internationalen Stil«. Wichtig für einen Ausgleich der Ungleichheit dieser Welt ist die architektonische Selbstvergewisserung einer Gesellschaft. In der Welt der Architektur ist der Weg schon gut beschritten, indem die Wertmaßstäbe im internationalen Vergleich keine abstrakten sind, sondern sich an den Tiefen der kulturellen Wurzeln eines Projekts messen. Die Architekturszene ist – zumindest in wesentlichen Teilen – divers und vielfältig ästhetisch.

Die DIA ist ein Teil dieses Diskurses durch die internationalen Studierenden, die ihre Kultur mitbringen. Ihr kultureller Hintergrund stellt geradezu eine Voraussetzung für das Lehrkonzept dar. Die DIA ist ein Ort, an dem internationale Themen diskutiert werden – nicht mittels stilistischer Definitionen oder durch die Vermittlung einer bestimmten Ästhetik, sondern als Arbeitsweise: eine Methode, fünf Dimensionen zu verhandeln. Hier gebührt der Dank unseren Studierenden, die uns als Lehrer viel geben, weil sie uns an ihrer Kultur teilhaben lassen. Die Spannbreite der studentischen Arbeiten in ihrer kulturellen Verwurzelung einerseits und in der authentischen Gegenwart andererseits ist immer wieder faszinierend und eine Qualität für sich. Sollte es einmal ein neues Bauhaus geben, dann hätte es dieses Element: die Internationalität als Grundvoraussetzung für die Kalibrierung einer neuen Architektur – von einem europäischen Projekt zu einem globalen Projekt.

Noch ist nicht ganz begriffen worden, dass die DIA mit ihrem Lehrprofil nicht nur in Dessau eine Vorreiterrolle hat, sondern in ganz Deutschland. Oft wird dies erst im Rückblick deutlich. Wir haben viel zurückgeschaut in diesem Bauhaus-Jubiläumjahr. Blicken wir zukünftig auf die DIA, auf ihre Lebendigkeit, ihre Attraktivität, ihre Zukunft, schauen wir auf das andere Ende des Bauhauses, auf eine Architekturschule, die es seit dem Bauhaus in Dessau bislang so nicht mehr gegeben hat!

Not least of all, the Biennale exhibitions of previous years bear witness to that. Architecture is the primary medium where society can find itself or find reassurance in itself. There is no interest in an “international style”. What is important to compensate the inequality of this world is a society’s architectural self-affirmation. It has already been firmly established in the world of architecture that the value benchmarks in international comparisons are not abstract but are measured against the depths of a project’s cultural roots. The architectural scene is—at least in essential parts—diverse and aesthetic in many different ways. DIA is a part of this discourse through its international students who bring their culture with them. Their cultural background almost constitutes a prerequisite for the teaching concept. DIA is a place where international topics are discussed—not using stylistic definitions or by conveying a particular aesthetic but as a working method for negotiating five dimensions. Here, our thanks must go to our students who give a lot to us as educators by inviting us to share their culture. The breadth of the students’ works, in terms of their cultural roots on the one hand and in the authentic present on the other, continuously fascinates and is a quality in itself. If there ever is a new Bauhaus, it would have this element: internationality as a basic prerequisite for calibrating a new architecture—from a European project to a global project. What has yet to be fully understood is the fact that DIA with its teaching profile plays a pioneering role not only in Dessau but throughout Germany. Often, this only becomes clear in hindsight. We looked back a lot during this Bauhaus anniversary year. If in the future we take a look back at the Dessau Institute of Architecture (DIA), at its vitality, its sheer attractiveness and its subsequent achievements then we are looking at the legacy of the Bauhaus—at a School of Architecture the likes of which has not been seen since the Bauhaus in Dessau!



**Lehrkonzepte aus
einer Hand**
Pedagogical
concepts from
a single source



Image: Guggenheim-Museum Bilbao, Stock-Fotografie-ID:498950522

Was Forschung mit Intuition verbindet

Alfred Jacoby

Um eine Antwort auf diese Frage zu finden, ist es zunächst erforderlich, die Anwendbarkeit einer Methode zu überprüfen, die Architektur als ein schwarz-weißes Nebeneinander von Begriffen diskutiert. In seinem Buch *We Have Never Been Modern* (1991) bewertet Bruno Latour diese Methode des Entweder-Oder sehr kritisch. Er bezeichnet sie als einen der Hauptmängel der Moderne:

»Verzagt nicht an den Schäden, die das Moderne Projekt verursacht hat. Die Manie für die Reinheit, erreicht durch die dauerhafte Unterteilung der Dinge, war tatsächlich kostspielig. Doch glücklicherweise fügten die Modernen mit der einen Hand das wieder zusammen, was sie mit der anderen entzweit hatten. Das Werk der Reinigung wurde immer begleitet durch die Mediation. Wir können die Errungenschaften der Aufklärung behalten, auch ohne die Moderne.«

Latour rät, die modernistische Schwarz-Weiß-Malerei durch eine nicht-ideologisierte Designlandschaft voller Wissen zu ersetzen. Sein Beurteilungsinstrument basiert auf Mediation. Es bedeutet immer: Dialog.

Schauen wir uns einige Beispiele an. Eine der starren Überzeugungen der frühen Architekturmoderne war die klare Trennung verschiedener Funktionsbereiche innerhalb einer Stadt (Wohnzonen, Arbeitszonen, Dienstleistungszonen etc.). Diese Überzeugungen wurden 1939 in der Charta der *Congrès Internationaux d'Architecture Moderne* (CIAM) festgehalten.

Zwanzig Jahre später, 1959, fand der letzte CIAM-Kongress im niederländischen Otterloo statt. Inzwischen hatte eine Gruppe junger Architekten, die aus den CIAM hervorgegangen war und als *Team 10* bekannt wurde, die CIAM für tot erklärt. Zu ihren Mitgliedern zählte der Schweizer Bernhard Hoesli, der im Atelier von Le Corbusier in der Rue de Sèvres in Paris gearbeitet hatte und zum damaligen Zeitpunkt

Architecture as Intuition or Research?

One of the four Symposium Panels on the occasion of the 20th Anniversary of DIA in October 2019 asked its participants to discuss the question: Architecture as Intuition or Research? In order to find an answer regarding the above, it is first of all necessary to review the validity of a method that discusses architecture as a black and white juxtaposition of terms. In his book, *We Have Never Been Modern* (1991), Bruno Latour sees the method of an either/or very critically. He points it out as one of the main deficiencies in modernism. He writes: Do not despair over the damage brought about by the Modern Project. Its mania for purification, that is, for dividing things in two and keeping them apart, was truly costly but luckily the modernists were undoing with one hand what they were doing with the other. The work of purification was always accompanied by the work of mediation." Latour concludes: "We can keep enlightenment without modernity." Latour recommends replacing the modernist black and white geography with a new, non-ideological design landscape filled with knowledge. His instrument of assessment is based on mediation, which always means dialogue. Let us look at some examples:

One of the rigid beliefs of early modernism in architecture was the clear separation of different functional zones within a city (living zones, working zones, servicing zones, etc.). Le Corbusier's *Ville Radieuse* (1924) is an excellent example of this. These beliefs were finally canonised in the Charter of the *Congrès Internationaux d'Architecture Moderne* (CIAM) in 1939. Twenty years later, in 1959, the last CIAM Congress was held in Otterloo (NL). By then, a group of architects, who became known as *Team 10*, had declared CIAM dead.

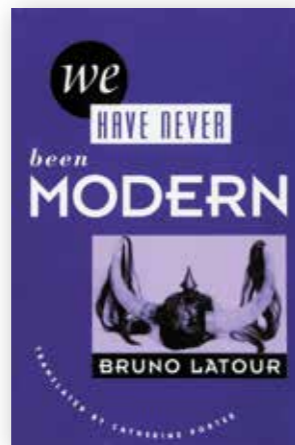

left: Le Corbusier's boldest contribution to modern architecture is the realisation of his dream of the city of tomorrow: »La Ville Radieuse«.

Le Corbusier: La ville radieuse. Éléments d'une doctrine d'urbanisme pour l'équipement de la civilisation machiniste, Paris 1964

What does it mean to be modern? This book, an anthropology of science, shows us how much of modernity is actually a matter of faith. Bruno Latour, Catherine Porter: We have never been modern, Cambridge 1993

left: CIAM was one of many 20th century manifestos meant to advance the cause of »architecture as a social art«.

right: »Who will stand up to the giants of Modernism?« That was the question facing Team 10, a group of young European architects after the end of CIAM (1959).

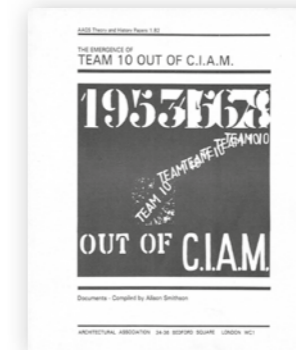

Bernhard Hoesli, a Swiss architect, who had worked in Le Corbusier's atelier at Rue de Sèvres in Paris, was one of the accompanying members, who by that time was teaching architecture in Austin (Texas). He never believed in rigid formalisms and saw architecture as a result of a continuously evolving process, a result of Collage. Together with his Texan colleague, Colin Rowe, he established this new way of working in their jointly published book *Collage City* (1978). As head of the 1st year preparatory course at the ETH in Zurich, Bernhard Hoesli described the making of architecture in a diagram. In it, he shows how architecture is created as a result of mediating process—very much in the spirit of Bruno Latour. His diagrammatic timeline involves the design stages of dialogue, composition and creation. It is centred around what he describes as his Architectural Zero Point (*Architektonischer Nullpunkt*). One quickly realises that this moment is a turning point within a fluid process. The zero is the exact point where the syntax used to describe architecture changes from speech to drawing.

His zero is not a black or white decision-making point in time. It is a complete refutation of what the logician and philosopher Ludwig

Architektur in Austin (Texas) lehrte. Hoesli glaubte nie an starre Formalismen, vielmehr sah er Architektur als Resultat eines kontinuierlich ablaufenden Prozesses, als ein Ergebnis von *Collage*. Mit seinem texanischen Kollegen Colin Rowe machte er diese neue Herangehensweise in ihrem gemeinsamen Buch *Collage City* (1978) publik.

Als Leiter des Vorkurses des 1. Studienjahrs an der ETH Zürich beschrieb Hoesli die Entstehung von Architektur in einem Diagramm, die Entwurfsfindung als einen Vermittlungsprozess – ganz im Sinn von Bruno Latour. Seine Zeitachse umfasst die Entwurfsphasen Dialog, Komposition und Kreation. Sie drehen sich alle um einen sogenannten architektonischen Nullpunkt. Dieser ist der Wendepunkt innerhalb eines laufenden Prozesses, an dem sich die Art der Beschreibung von Architektur ändert: von der Sprache zur Zeichnung. Der Nullpunkt unterscheidet nicht zwischen Schwarz oder Weiß.



Diagramm: Entstehung von Architektur als Vermittlungsprozess. Dabei führt die Arbeit des Architekten von der verbal formulierten zur räumlichen Form. Bernhard Hoesli: Architektur lehren, Zürich 1989

Dies ist eine völlige Widerlegung dessen, was der Logiker und Philosoph Ludwig Wittgenstein in seinem *Tractatus logico-philosophicus* (1918) postuliert hat: »Wovon man nicht sprechen kann, darüber muss man schweigen.« Hoesli zeigte, dass es in der Architektur mehrere »Sprachen« gibt, um eine *Gestalt* zu kreieren. In der Architektur ersetzt die gesprochene Sprache das Unsagbare. Hier nimmt die Architektur eine komplexe Position ein. In sämtlichen Gestaltungsdisziplinen müssen immer **sowohl Intuition als auch Forschung** zur Anwendung kommen. Bei Gestaltungsfragen ist das Zusammenwirken, die Collage von *Forschung und Intuition* richtig und wirkungsvoll. In einem kontinuierlich ablaufenden Prozess hat sich im Laufe der Jahrhunderte die moderne Forschungsmethodik von einem kanonisierten (klerikalen) Glauben hin zur rein evidenzbasierten Beweisfindung entwickelt. Die Anwendung des von Hoesli beschriebenen Prozesses zeigt, dass das schwarz-weiße beziehungsweise dunkel-helle Realitätsverständnis mehr von gegenseitigen Abhängigkeiten geprägt und weniger eindeutig ist. Auch der Beweis, der Ausgangspunkt auf Hoeslis Nullpunktachse, kann hybride sein. Zur Untermauerung der Überzeugung, dass das *Entweder-oder* durch das *Sowohl-als-auch* ersetzt werden sollte, seien einige Beispiele genannt.

Erstes Beispiel: Foto eines Küchentischs

Hier finden wir ein intuitives Verständnis von kreisförmigen Formen und Farben. Es ist eine Komposition, die der

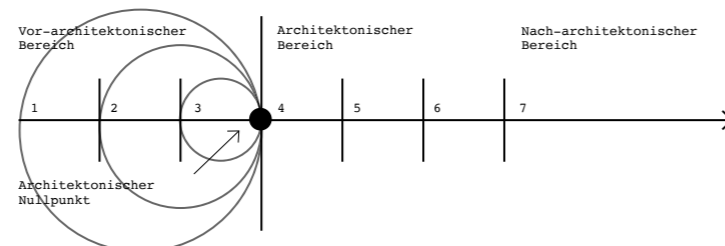
Wittgenstein had earlier declared as his zero point. In his *Tractatus logico-philosophicus* (1918), he claims that what one cannot speak about must remain silent. For architecture, Bernhard Hoesli replaced that belief by showing that in architecture there are more "languages" available to attain a "gestalt" or design. In architecture, spoken language is replacing the unspeakable. Here, architecture assumes a much more hybrid position. All design disciplines always need the application of both intuition and research. I also believe that, for design questions, the pairing of research and intuition as a collage is ultimately a correct and useful relationship. Modern research is a method that developed equally as a fluid process over the centuries. It began with canonised (clerical) belief and ended up in a purely evidence-based proof. Applying the process that Bernhard Hoesli described leads me to the position that the black and white or dark and enlightened understanding of reality is a much more interdependent and very much less clear-cut affair. Even proof, as a departure point on Bernhard Hoesli's zero point axis, can be of a hybrid nature too. To underpin this conviction that the either/or should be replaced with as-well-as I want to demonstrate this by using several different examples.

linke Seite/Bild 1: Küchentisch mit kreisförmigen Formen und Farben in zufälliger Anordnung.
Foto: Kaia Jacoby



linke Seite/Bild 2: Das arrangierte Bild einer Wohnung mit unbekanntem Bewohner.
Foto: NZZ Folio, Heft 10/2006



rechte Seite/Bild 1: Architekturmodell des Opernhouses in Sydney, Australien;
Architekt: Jørn Utzon.
Foto: Museum of Applied Arts and Sciences

rechte Seite/Bild 2: Orangenschalen.
Foto: Alfred Jacoby



The first example: photo of a kitchen table

As a first example, I would like to introduce a photo of a kitchen table. In it, we find an intuitive understanding of circular forms and colours. It is a composition, which the observer, in this case the photographer, brings to reality by creating an image. Otherwise, the arrangement of the objects would be completely random. The composition only comes to life through the photo. Considering the circumstances, it is reasonable to assume that it was not made up as one of a series of experimental photos: It was sent to me by my granddaughter Kaia, aged three. She is certainly not a trained photographer.

The second example: arranged image—Neue Zürcher Zeitung (2006)

This image is totally composed. It was used in a workshop of a Zürich-based psychologist, Harry Tyrangiel, who came to DIA to work with students. The task he set our students was to discover the professions of the people inhabiting the flat. The way to find out was entirely through dialogue between him and the group of students, reviewing the objects placed within the space. Once again a great deal of intuitive knowledge, which emerged from a debate amongst students as trained experts, was used to find the right answer. It took only 45 mins.

The third example: Sydney Opera House

In his book *Space, Time, and Architecture*, Sigfried Giedion reports, how Jørn Utzon first played with orange peels and then found the

Betrachter, in diesem Fall die Fotografin, durch die Erstellung eines Bildes in die Realität umgesetzt hat. Andernfalls wäre die Anordnung der Objekte völlig zufällig. Die Komposition wird eigentlich erst durch das Foto zum Leben erweckt. In Anbetracht der Umstände kann man davon ausgehen, dass es sich nicht um eine Serie von experimentellen Fotos handelt: Das Bild wurde von meiner dreijährigen Enkelin Kaia, einer nicht ausgebildeten Fotokünstlerin, gemacht.

Zweites Beispiel: Ein arrangiertes Bild

Dieses Bild ist komplett durchkomponiert. Es entstand im Rahmen eines Workshops, den der Zürcher Psychologe Harry Tyrangiel an der DIA durchführte. Den Studierenden stellte er die Aufgabe herauszufinden, welchem Beruf der Bewohner der auf dem Foto dargestellten Wohnung nachging. Dies sollte mithilfe eines Dialogs zwischen Tyrangiel und den Studierenden geschehen, indem die im Raum platzierten Objekte besprochen wurden. Es wurde wiederum viel intuitives Wissen genutzt, das in der Diskussion unter den Studierenden herausgearbeitet wurde. Letztlich dauerte es nur 45 Minuten, bis die richtige Antwort gefunden war.

Drittes Beispiel: Das Opernhaus Sydney

Der Schweizer Architekturhistoriker Sigfried Giedion beschreibt in einem Kapitel seines Buchs *Space, Time and Architecture*, wie Jørn Utzon zunächst mit Orangenschalen experimentierte und dann durch eine geometrische Studie die

Form seiner berühmten Dachkonstruktion fand. Ich nenne das Spiel mit den Orangenschalen intuitiv, weil es die gesuchte Endform voraussetzte. Intuition und Forschung ermöglichten es Utzon, seine erste Idee in etwas Baubares umzusetzen.

Viertes Beispiel: Das Olympiastadion in München

Das Dach des Münchner Olympiastadions von Frei Otto basiert auf einem klassischen Versuchsaufbau. Zunächst wurde mit Seifenblasen experimentiert, um die Zugeigenschaften dünner Membranen zu testen. Danach wurden die Forschungsergebnisse maßstabsgerecht 1:1 umgesetzt. Diese Membranstruktur ist die zweite ikonische Form in meiner Beispielreihe, die sich auf eine Reihe von Versuchen zurückführen lässt. Dies ist die klassische Methode der Forschung. Beide Beispiele, das Opernhaus Sydney und das Münchner Stadion, demonstrieren, dass Intuition und Forschung nie ein Entweder-Oder sind.

Fünftes Beispiel: Das Grazer Kunstmuseum

Der britische Architekt Peter Cook suchte beim Entwurf des Grazer Kunstmuseums nach der optimalen Position für den »Blob«, den er in einen streng orthogonalen Raum stellte. Sein Ziel war es, die räumliche Spannung zwischen der kartesischen Ordnung des Grazer Stadtplans und seiner Ordnung der freien Form zu maximieren. Um dies zu erreichen, erhielt Cooks Projekt in einem Prozess langsamer Annäherungen seine Form. Hier kann der klassische Versuchsaufbau

form of his famous hoods by a process of geometrical research. I call the play with orange peels intuitive because it presupposed the final form he searched for. Both intuition and research enabled him to translate his first idea into something that could be built.

The fourth example: Munich Olympic Stadium

The roof for the Munich Olympic Stadium by Frei Otto was based on a traditional experimental setup. The form initially derives from experiments with soap bubbles, which help supply an understanding of the tensile properties of thin membranes. To transform the results to reality, the findings are statically transformed into a proper 1:1 scale. In the end, the constructed result employed plastic resin as a thin membrane. That formed the skin structure of the final shell. It is the second iconic form in my set of examples. It can easily be traced back to a series of experiments and their optimum outcome. And that in itself is the traditional method of research. Both examples, the Sydney Opera House and the Munich Stadium, show that intuition/research is never an either/or.

The fifth example: Graz Art Museum

What the architect Peter Cook looked for when creating the Graz Art Museum was to look for the best position for the blob, which he put into a strictly orthogonal space. His aim was to maximise the spatial tension between the cartesian order of the Graz City Plan and his order of free form.

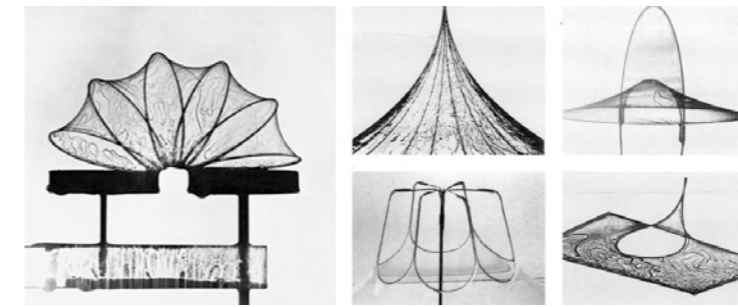
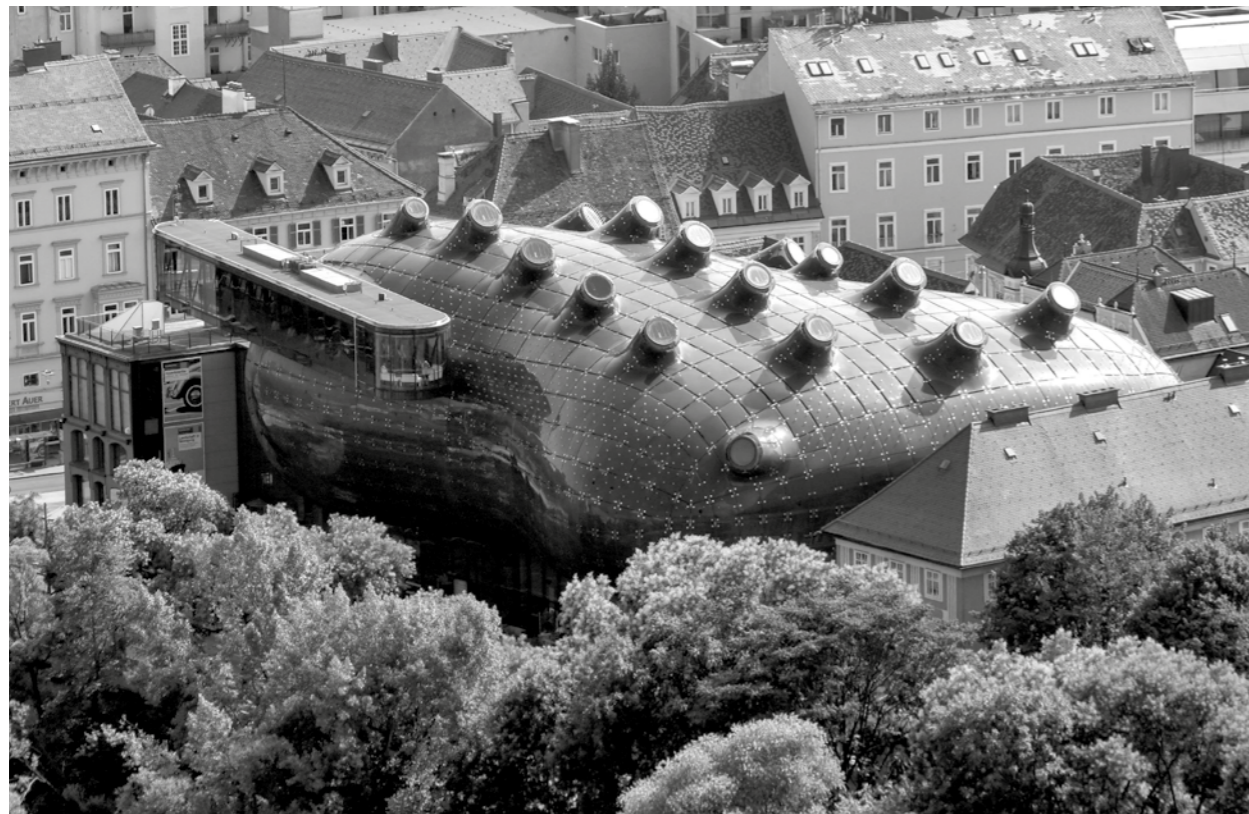

Seifenblasenexperimente von Frei Otto (1964).
Foto: Institut für leichte Flächentragwerke (IL)
der Universität Stuttgart

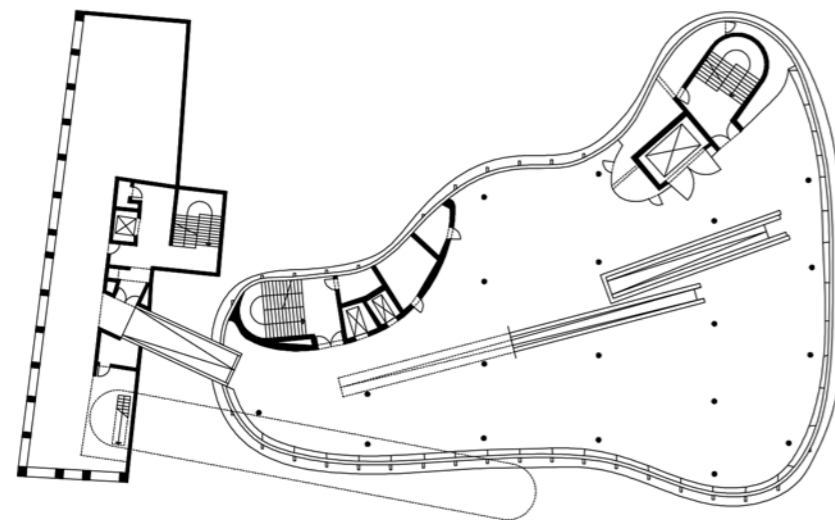

Kunsthhaus Graz, Schweiz.
Foto: Stock-Fotografie-ID: 485335114, Tg50
Zeichnung: Peter Cook/Colin Fournier

von Frage-Forschung-Experiment und Resultat nicht unbedingt nachgewiesen werden. Vielmehr wird zunächst eine intuitive Idee formuliert, die durch einen Annäherungsprozess ihre Form erhält. Was Cook nicht erwähnt, ist, dass sein Findungsprozess den Computer erfordert: die extrem genaue, unnachgiebige Maschine auf 0/1-Basis. Ohne den Computer wäre es sehr viel komplizierter oder vielleicht sogar unmöglich gewesen, das Gebäude zu realisieren.

Im Grazer Beispiel sehe ich den stärksten Ausdruck dessen, was Latour mit Mediation meinte. Es ist kein Versuchsaufbau, der das Ergebnis bestimmt, sondern ein intuitives Verständnis einer architektonischen Idee, bei dem die 0/1-Maschine lediglich als Werkzeug dient. Mit diesen Aspekten im Hinterkopf werden die folgenden Fragen für jeden relevant sein, der in einen Gestaltungsprozess involviert ist.

- Ist architektonische Kreativität meist eine Entweder/Oder-Situation für den Entwerfenden?
- Wie geht der Entwerfende den Entwurfsprozess vom Wort zum Material an?
- Wo stehen die 0/1-Maschinen innerhalb der architektonischen Tradition?

To achieve this, Peter Cook explained that his project gained its form in a process of slow approximations. Here the classical set up of question/research/experiment and result cannot strictly be proven. In Graz, an intuitive idea is first formulated, gaining its form through a process of approximation. Of course, what Peter Cook does not mention is that the process of discovery needs a computer—that extremely accurate and unforgiving machine based on ones and zeroes. Without this machine, it would have been very much more complicated or maybe even impossible to actually realise the building. In the Graz example, I find the strongest expression of what Latour meant by mediation. It is not an experimental set up that determined the result, but rather an intuitive grasp of an architectural idea using the digital machine merely as a tool. With this article in mind, some questions will always be relevant for anyone involved in a design process:

- Is architectural creativity mostly an either/or situation for you?
- How do you tackle the process from word to material?
- How do you view the digital machine within the architectural tradition?



Foto: Denis Esakov

Berufsvorbereitung für den Architekten

Natascha Meuser

Bei der Vorbereitung von jungen Menschen auf eine unsichere Zukunft kann es nicht im Zentrum der Lehre stehen, in Konzentration auf die hierarchisch höhergestellte Lehrperson per Frontalunterricht vermeintliche Wahrheiten oder Lösungswege zu vermitteln. Gerade in den hochqualifizierten Berufsfeldern des Arbeitslebens ist zunehmend die Fähigkeit gefragt, mit Unbestimmtheit umgehen zu können – jene Fähigkeit also, die das Wesen wissenschaftlichen Forschens ausmacht. In diesen sich wandelnden Zeiten, angesichts rasanter Entwicklungen in der Technik sowie Globalisierung und Digitalisierung muss auch die Architekturausbildung jenseits willkürlicher Gegebenheiten offen strukturiert sein und sich nicht an eventuell schon bald (oder gar längst schon) überholten Ritualen der Vergangenheit festklammern. Eine zeitgemäße Lehre soll selbstverständlich tradierte, erprobte Techniken vermitteln, ohne jedoch dabei so zu tun, als seien die Lösungen der Vergangenheit mit Sicherheit auch für die Zukunft tauglich. Es geht bei einer wissenschaftlichen Ausbildung nicht um die Vermittlung von Lösungen, sondern vielmehr um die Schärfung der Wahrnehmung für Probleme, um die beständige Reflexion der teils sich ändernden, teils erschreckend konstant bleibenden gesellschaftlichen Kernfragen der Gegenwart. Und da sich die Zukunft unerwartet entwickelt, sollten auch die Studierenden dazu ermutigt werden, Unerwartetes zu präsentieren und zu leisten. Die Lehre und insbesondere die Benotung kann sich nicht in der bloßen Abgleichung von Lehrer-Erwartung und Schüler-Leistung erschöpfen. Fantasie und Fiktion außerhalb des Erwartungsrahmens sind es, die neue Lösungen für teils alte Planungsaufgaben liefern. Ebenso kann sich die unter dem Schutz der wertvollen akademischen Freiheit stehende Forschung nicht in der historischen Ausführung ihrer Werke oder in der musealen Konservierung jenes Teils der Vergangenheit erschöpfen, der gerade aktuell in Mode ist. Die Fragen und

Professional Preparation for the Architect

When preparing young people for an uncertain future we cannot allow a focus on a plethora of supposed truths and possible solutions to be at the forefront of our teaching—often delivered by those lecturers higher up the academic hierarchy and often in a didactic ‘chalk and talk’ style. With regard to highly qualified occupations in particular in working life, the ability to handle uncertainty is an increasingly sought-after skill—a skill which indeed goes to make up the very essence of academic research. Within these ever-changing times and in light of the furious pace of developments in technology, globalisation and digitalisation, the teaching of architecture must be designed to be open and ready to face whichever arbitrary conditions may arise. We must not cling on to those ritual certainties of the past which may soon be (or may even have long been) rendered obsolete. Contemporary teaching must of course convey traditional, well-proven techniques—but should not however do so in such a way as to suggest that solutions from past times will be unerringly suitable for the future. A university education is not about imparting solutions, but rather about finely honing a capacity for discerning and dealing with problems and about constantly reflecting upon the prevalent social issues of the day—which in part may change and in part may remain alarmingly consistent. Given that the future will unfold in an unexpected manner, students should similarly be encouraged to show work that is unexpected and to achieve that which is unexpected. Successful teaching and the awarding of marks in particular cannot be based on merely comparing the expectations of teachers with the achievements of students. It is beyond the realms of fantasy and fiction to deliver new solutions to partially long-gone planning challenges. Likewise, research which falls under the protection of precious academic

Lehrkonzepte aus einer Hand
Pedagogical concepts from a single source

freedom cannot be confined to the historic execution of its findings nor to the antiquated conservation of fragments of the past currently in vogue. Questions and proposals to solve the issues of our day continuously arise within what were initially neglected and ridiculed niche areas which did not conform to what the broad and expert public jointly deemed a prestigious and recognised sphere of activity. Methodology must therefore be open and undogmatic in the approach to problem-solving. The individuality of students and their personal problem-solving approaches—independently arrived at—ought to be taken seriously and supported.

Bauhaus as a School

Today the classics within the history of architecture and design trade under the 'Bauhaus' label—and that includes among others the Bauhaus building or the *Meisterhäuser* (Masters' Houses) in Dessau which are included on the UNESCO World Heritage List under "Bauhaus and its Sites in Weimar, Dessau and Bernau." Those buildings and properties emanating from Bauhaus not only reflect a diversity which is nowadays often only perceived in a very curtailed form and is one which can scarcely be reduced to one common denominator, even with the greatest rhetorical effort. Bauhaus is evidently not a conglomeration of normative design regulations, but rather a dynamic approach to the ever-topical issue of how to solve pressing contemporary design problems both effectively and satisfactorily from an aesthetically pleasing standpoint. This does not primarily involve buildings dominated by stringent objectivity and cubic clean white surfaces, but rather the dissemination of ideas, from teachers referred to as "masters", being passed down to their keen students, referred to as "apprentices". Were Bauhaus merely a 100-year-old avant-garde concept it would have been rendered obsolete or evolved into a lifeless cliché by today. Instead, the Bauhaus

Problemlösungsvorschläge unserer Zeit entstehen immer in zunächst vernachlässigten und belächelten Nischen, die nicht dem entsprechen, was die breite (Fach-)Öffentlichkeit gern als repräsentatives, anerkanntes Betätigungsfeld erachtet. Die Methode muss also offen sein und in ihren Lösungsansätzen undogmatisch. Auf einer soliden fachlichen Basis soll gerade die Individualität des jeweiligen Studierenden samt seiner eigenständig entwickelten persönlichen Lösungsansätze ernst genommen und gefördert werden.

Das Bauhaus als Schule

Klassiker der Architektur- und Designgeschichte firmieren heute unter dem Label »Bauhaus« – so unter anderem auch das Bauhausgebäude oder die Meisterhäuser in Dessau, die zum UNESCO-Welterbe »Das Bauhaus und seine Stätten in Weimar, Dessau und Bernau« zählen. Die aus dem Bauhaus hervorgegangenen Gebäude und Objekte weisen nicht nur eine heute oftmals nur sehr verkürzt wahrgenommene Vielfalt auf, die selbst bei größter rhetorischer Anstrengung kaum auf einen gemeinsamen Nenner gebracht werden kann. Offenkundig war das Bauhaus kein Konglomerat normativer Formgebungsvorschriften, sondern vielmehr eine dynamische Herangehensweise an die immer aktuelle Frage, wie akute zeitgenössische Gestaltungsprobleme effektiv und ästhetisch befriedigend zu lösen sind. Es geht eben nicht in erster Linie um die von strenger Sachlichkeit und kubisch klaren, weißen Flächen geprägten Bauwerke, sondern um die Weitergabe von Ideen von als »Meistern« bezeichneten Lehrerinnen und Lehrern an als »Lehrlinge« bezeichnete interessierte Studierende. Wäre das Bauhaus lediglich ein inzwischen 100 Jahre altes Avantgarde-Konzept, dann wäre es heute veraltet oder zum Klischee erstarrt. Die Revolution des Bauhauses aber wurde initiiert in Form eines revolutionären pädagogischen Konzepts, nämlich einer Hochschule

für Gestaltung, die in Zeiten der Industrialisierung und Massenfertigung die zwischenzeitlich fahrlässig getrennten Disziplinen Kunst und Handwerk wieder zusammenzubringen suchte.

Wie aber bildet das Individuum sich zu einem Ganzen? Indem es die Welt erforscht – nicht im Sinne einer Anleitung von außen, sondern indem der Mensch sein ureigenstes Wesen auslebt und sich interessiert mit der Welt auseinandersetzt. Dies war auch der Kerngedanke von Wilhelm von Humboldts Vorstellung, wie eine Universität zu funktionieren habe. Der Lehrer ist in diesem Sinne weniger ein Vermittler von Lehrstoff, sondern gibt vielmehr durch eigene Forschungsvorhaben ein Beispiel für die Studierenden, die er somit zu ergebnisoffenem, forschendem Lernen anleitet. Diese Konzeption hat bis heute kaum etwas von ihrer Strahlkraft verloren und wird immer wieder neu entdeckt. Forschendes Lernen zeichnet sich vor anderen Lernformen dadurch aus, dass es auf die Gewinnung von auch für Dritte interessanten Erkenntnissen ausgerichtet ist. Die Studierenden bestimmen in aktiver Mitarbeit die wesentlichen Phasen eines Projekts – von der Entwicklung der Fragen und Hypothesen über die Wahl und Ausführung der Methoden bis hin zur Prüfung und Darstellung der Ergebnisse. Sie **gestalten, erfahren und reflektieren**.

Die Forderung, dass die Erkenntnisse auch für Dritte interessant zu sein haben, resultiert daraus nahezu zwingend. Da man doch stark hoffen darf, dass die Lehrenden zumindest die Grundzüge des eigenen Lehrgebiets kennen, kann in der bloßen Repetition bekannter Sachverhalte keine verlockende Information liegen. Somit wird zwar insgesamt keine Neuerung zu erwarten sein, wohl aber eine eigene Note. Wichtig in diesem Kontext ist aber vor allem, dass Hochschullehre sich nicht erschöpfen darf in der Überprüfung eines Lerngewinns

revolution has been initiated in the form of a revolutionary pedagogical concept, namely a School of Design which during the age of industrialisation and mass production sought to bring together again the disciplines of art and craftsmanship which had been negligently allowed to part company in the interim. How, however, does the individual study and learn to fulfil their whole potential? By exploring the world—not in the sense of receiving guidance from outside, but by each of us giving rein to our innate character and making our way in the world with a questioning mind. This was also the core tenet behind Wilhelm von Humboldt's concept as to how a university should operate. In line with this thinking teachers convey less material, but rather set students an example using their own research findings and in so doing prompt in the student a research-oriented learning style, free from preconceptions. This theory has lost scarcely any of its mass appeal to this day and is continuously being discovered anew. Research-oriented learning can be distinguished from other forms of learning in that it is aimed at the acquisition of knowledge which will also be of interest to third parties. Through active cooperation students determine the essential phases of a project—from the formulation of questions and hypotheses through to the selection and execution of methods and on to the examination and presentation of results. Thereby they are creating designs, gaining experience and reflecting.

The requirement resulting therefrom—that findings must also be of interest to third parties—is virtually a necessity. Since we very much hope that teachers are acquainted with at least the fundamentals of their own subject fields it is unlikely that the mere repetition of well-known facts will contain appealing information. With that approach innovation is on the whole not to be anticipated, although an individual grade will be. It is important to note

in this context that it is impossible to achieve the best higher education teaching based on the examination of learning goals or appraisals of learning outcomes measured against objective criteria deemed as quantifiable as possible (the prior definition of which would in itself pose a major obstacle to truly individual achievements). In any case it is not the accumulation of facts which captures the essence of academic knowledge, but rather the posing of questions. It is the students themselves who will explore their own research fields, within certain predetermined parameters of course. In this process universities tend to offer more of a supportive accompaniment.

This concept would now seem to be initially conclusive, but it rather poses an immense challenge when examined in further detail. For students at the beginning of their studies are ultimately being expected to pursue their own individual path with an incomplete knowledge of the basics of their disciplines. One approach in this respect lies in the research-oriented learning of university researchers. The latter will pursue their own path and take students along on research trips at least part of the way, involving them in their own projects pursuant to their skills and talents. Whereas Wilhelm von Humboldt highlighted the importance of general education, focussing a great deal on the intellect, and—in delimiting those lecturing staff without research projects—conceived of the university as a place where research and education, driven by academic freedom, went hand in hand, Bauhaus, in its role as a training institution in the broadest sense attempted to combine more intensively the practice of craftsmanship with a knowledge of aesthetics. Walter Gropius referred to a “Bauhaus educational method” which “not only sharpens the intellect, but also shapes our sensibilities and trains our eyes and hands.” Bauhaus was in essence a pedagogical effort which was to be the outcome of a new type of aesthetic

oder in der Bewertung einer Lernleistung nach möglichst quantifizierbaren objektiven Kriterien (deren Definition im Vorfeld allein schon ein großes Hemmnis für wirklich individuelle Leistungen wäre). Wesen der Wissenschaft ist ja ohnehin eben nicht die Anreicherung von Fakten, sondern das Stellen von Fragen. Die Studierenden selbst sind es, die, selbstverständlich innerhalb gewisser vorgegebener Parameter, eigene Forschungsbereiche erkunden. Die Hochschule bietet hierbei eher eine Begleitung.

Nun scheint das Konzept zunächst schlüssig, ist aber genauer betrachtet eine immense Herausforderung. Denn schließlich sollen die Studierenden mit zu Studienbeginn noch unvollständiger Kenntnis der Grundlagen ihrer Fachdisziplin ihren individuellen Weg finden. Der Lösungsansatz hierfür ist im Forschenden Lernen der Forschende Hochschullehrer. Dieser beschreitet seinen eigenen Weg und nimmt seine Studierenden zumindest ein Teilstück mit auf die Forschungsreise, indem er sie ihren Fähigkeiten und Talenten gemäß in seine eigenen Projekte einbindet. Während der stark auf den Intellekt konzentrierte Wilhelm von Humboldt die Bedeutung der Allgemeinbildung unterstrich und – in Abgrenzung von Lehrprofessoren ohne Forschungsprojekte – die Universität als einen Ort konzipierte, an dem mit akademischer Freiheit betriebene Forschung und Lehre Hand in Hand gehen, versuchte das Bauhaus in seiner Funktion als Ausbildungsstätte im weitesten Sinne die Praxis des Handwerks noch stärker mit der Wissenschaft der Ästhetik zu verbinden. Walter Gropius proklamierte eine »Bauhaus-Erziehungsmethode«, die »nicht nur den Verstand schärft, sondern auch unser Empfindungsvermögen formt und Auge und Hand trainiert«. Das Bauhaus war somit im Kern eine pädagogische Anstrengung, die das Resultat einer neuartigen ästhetischen Erziehung sein sollte – ganz im Sinne der um 1900 aufgekommenen Utopien der »Lebensreform« und des »Neuen Menschen«.

Dabei war der Erziehungsbegriff sehr weit gefasst. Wie das Bauhaus seine Schülerinnen und Schüler erzog, so sollten diese später erzieherisch auf die Gesamtgesellschaft einwirken. Vorbilder waren zunächst die Reformpädagogik und ihre Vorläufer wie Jean-Jacques Rousseau mit ihrer ganzheitlichen Betrachtung des Menschen als leiblich-seelisch-geistige Einheit. Bemerkenswert sind beispielsweise die Einflüsse der Konzepte Friedrich Fröbels auf das Bauhaus: Sein System der Spielgaben, verwirklicht etwa in Bauklötzen, die auf geometrischen Grundformen basieren, diente offenkundig vielen Bauhaus-Entwürfen als Inspirationsquelle.

»Architekten, Maler und Bildhauer müssen die vielgliedrige Gestalt des Baues in seiner Gesamtheit und in seinen Teilen wieder kennen und begreifen lernen, dann werden sich von selbst ihre Werke wieder mit architektonischem Geiste füllen, den sie in der Salonkunst verloren«, proklamiert Bauhaus-Gründer Walter Gropius im April 1919 in seinem *Bauhaus-Manifest*. Es ist kein Zufall, dass der Name der neuen Institution auf die Bauhütten der mittelalterlichen Kathedralen anspielt, in denen Kunst und Handwerk Hand in Hand gingen.

»Das einflußreiche Erbe des 19. Jahrhunderts – die extreme Spezialisierung und das darauf folgende Zersetzen – belastet die sämtlichen Gebiete unseres heutigen Lebens und zwingt auch die Fragen des Kunstunterrichts immer tiefer in eine Sackgasse«, schreibt Wassily Kandinsky in seinem Artikel *Kunstpädagogik*, erschienen in der Zeitschrift *bauhaus* Nr. 2/3 im Jahr 1928: »Das ›entweder – oder‹ muß den Platz dem ›und‹ räumen. Eine Fachausbildung ohne allgemein-menschliche Grundlage sollte nicht mehr möglich sein. Es fehlt heute in jedem Unterricht – fast ohne Ausnahme – eine ›Weltanschauung‹ inneren Charakters oder die ›philosophische‹ Grundlage des Sinnes der menschlichen Tätigkeit. Merkwürdigerweise werden noch heute junge Leute auf die

education—entirely in keeping with the utopias of the *Lebensreform* (“Life Reform”) and that of *Der neue Mensch* (“New Man”) to emerge around 1900. This pedagogical concept was therefore very wide-ranging. Just as Bauhaus educated its students, the latter too were similarly to bear a subsequent influence upon the education of society as a whole. Initial role models were reformatory pedagogics and their precursors, such as Jean-Jacques Rousseau, with their holistic view of human beings as a physical, psychological and spiritual entity. The influence of the concepts of Friedrich Fröbel upon Bauhaus is noteworthy for example: his teaching method based on toys (*Spielgaben*)—such as basic geometric blocks—evidently served many Bauhaus designs as a source of inspiration.

“Architects, painters, and sculptors must once again come to know and comprehend the composite character of a building, both as an entity and in terms of its various parts. Then their work will be filled with that true architectonic spirit which, as ‘salon art’, it has lost.” claims Walter Gropius, the founder of Bauhaus, within his Bauhaus Manifesto of April 1919. It is no coincidence that the name of this new institution makes allusion to the builders’ and artisans’ associations of the medieval cathedrals in which art and crafts went hand in hand. “The influential legacy of the nineteenth century—the extreme specialisation and subsequent disintegration—burdens all areas of modern life, forcing the issues of the teaching of art ever deeper into a cul-de-sac,” writes Wassily Kandinsky in his article *Kunstpädagogik* (Art Pedagogy) published in the *bauhaus* journal, nos. 2/3, in 1928: “‘Either/or’ has to make room for ‘and’. Professional training without a general humanities basis should no longer be possible. Today, almost without exception, an outlook on life based on inner character or the philosophical foundation of the meaning of human activity is absent during each lesson.

It is curious that young people continue to be educated in an outdated, intrinsically destructive manner fostering professionals who may be very useful in the outer world, but who only very rarely represent a purely human value. The lesson is usually more or less a violent accumulation of individual pieces of knowledge which young people should strive to attain and which are of no use to them outside their 'subject'. Of course, the ability to amalgamate, in other words the ability to observe and conceptualise synthetically, is so little taken into account that it for the most part is left to atrophy." Within the curriculum of Bauhaus the vision of interdisciplinary teaching—which looks at the entirety of humanity—even broadened out beyond the arts disciplines, so that ultimately there can no longer be any talk of the direct utilisation of study materials for daily professional practice. It is notable that the teaching and training given bore the mark of the very individual personalities of the teaching staff. These were selected and appointed according to criteria reflecting the zeitgeist of the time, as was the case for the Deutscher Werkbund (German Arts and Crafts Society). Gropius concludes his Bauhaus Manifesto without being too specific: "Let us desire, conceive, and create the new building of the future together. It will combine architecture, sculpture, and painting in a single form, and will one day rise towards the heavens from the hands of a million workers as the crystalline symbol of a new and coming faith." The task of creating a building of the future is thus defined, albeit without setting out how this goal is to be achieved. As appropriate as it was in the years when the Bauhaus School existed to use simple, clear-cut forms in order to enable serial production in line with the industrial age, so is there less necessity for this today in an era of advanced fabrication techniques. And correspondingly the self-appointed mission of Bauhaus, to design for the future, undoubtedly continues to

veraltete und innerlich tötende Weise zu Fachmenschen erzogen, die im äußeren Leben sehr brauchbar sein können, aber nur ganz selten auch einen rein menschlichen Wert darstellen. Der Unterricht besteht in der Regel in einem mehr oder weniger gewaltsamen Aufhäufen von Einzelkenntnissen, welche die Jugend sich aneignen soll und mit welchen sie außerhalb ihres ›Faches‹ nichts anfangen kann. Selbstverständlich bleibt dabei die Fähigkeit der Verbindung, mit anderen Worten die Fähigkeit des synthetischen Beobachtens und Denkens so wenig berücksichtigt, dass sie größtenteils verkümmert.«

Im Curriculum des Bauhauses wurde die Vision einer interdisziplinären Lehre, die den ganzen Menschen im Blick hat, sogar über die bildkünstlerischen Disziplinen hinaus erweitert, so dass von einer direkten Verwertbarkeit des Studienstoffs für die alltägliche Berufspraxis endgültig nicht mehr die Rede sein kann. Auffällig ist hierbei, dass die Ausbildung von den sehr individuellen Persönlichkeiten des Lehrkörpers geprägt war. Diese waren nach dem damaligen Zeitgeist entsprechenden Kriterien, wie sie etwa auch den Deutschen Werkbund prägten, ausgewählt und berufen worden. »Wollen, erdenken, erschaffen wir gemeinsam den neuen Bau der Zukunft, der alles in einer Gestalt sein wird: Architektur und Plastik und Malerei, der aus Millionen Händen der Handwerker einst gen Himmel steigen wird als kristallenes Sinnbild eines neuen kommenden Glaubens«, beendet Gropius sein *Bauhaus-Manifest* – ohne hier allzu konkret zu werden. Die Aufgabe, einen Bau der Zukunft zu erstellen, wird somit formuliert, nicht aber, wie dieses Ziel zu erreichen sei. So angebracht es in den Jahren, als es die Bauhaus-Hochschule gab, war, einfache und klare Formen zu verwenden, um eine serielle Produktion im Sinne des Industriezeitalters überhaupt erst zu ermöglichen, so wenig ist dies in Zeiten fortgeschrittener Fabrikationstechniken heute noch notwendig.

Und entsprechend ist die selbstgestellte Bauhaus-Aufgabe, für die Zukunft zu gestalten, heute zwar noch aktuell, doch sie kann auf jeweils zeitgenössischen Wegen erreicht werden. »Vermeidung alles Starren; Bevorzugung des Schöpferischen; Freiheit der Individualität, aber strenges Studium«, definiert dies Gropius. Und auch Kandinsky proklamiert, dass »in erster Linie nicht das wichtig ist, was unterrichtet wird, sondern wie«. Das Bauhaus erscheint somit als Ort, an dem die Fächergrenzen überschreitend der Versuch unternommen wurde, einen ganzheitlichen Künstler zu formen, der die Herausforderungen der modernen Zeit bewältigen kann. Dies ging sogar so weit, dass Oskar Schlemmer ein eigenes Unterrichtsfach namens *Der Mensch* etablieren durfte, das philosophische, zeichnerische und biologische Bestandteile kombinierte.

Nicht nur als Professorin an der Hochschule Anhalt am Standort Dessau fühle ich mich in Forschung und Lehre der Bauhaus-Lehre verpflichtet – allerdings nicht in Form einer musealen Wertschätzung und Pflege. Die von Walter Gropius im Jahr 1922 formulierten Lehrprinzipien sind immer wieder neu interpretiert und den Anforderungen der jeweiligen Zeit angepasst worden. Immer wieder neu muss auch untersucht werden, was vom Bauhaus übrig geblieben ist beziehungsweise welche Impulse das Bauhaus für eine zukünftige Architektur heute noch setzen kann. Kurz gefasst heißt das: Wie wollen wir morgen leben?

Unverändert geblieben scheint leider die Diagnose des Bauhauses zu sein, dass die moderne Ausbildung zu sehr in Einfächer separiert ist – selbst in Bereichen, in denen die Forschung auf interdisziplinäre und transdisziplinäre Zugänge geradezu angewiesen ist. Immer noch muss der Fachbereich Architektur, Facility Management und Geoinformation der Hochschule Anhalt explizit deklarieren, dass es sein Ziel ist, Maßstäbe in der Ausbildung zu setzen, indem die

be topical today, although this can be achieved by following contemporary paths. "The avoidance of everything that is rigid; the preference for creativity; the freedom of individuality, but rigorous study," is how Gropius defines this. Kandinsky also claims that "What is important first and foremost is not what is being taught but rather how it is taught". Bauhaus thus appears as a place where attempts have been made across disciplinary boundaries to forge the 'total' artist capable of overcoming the challenges of modern times—to the extent that Oskar Schlemmer was allowed to establish his own course titled *Der Mensch* (The Human Being) which combined philosophical, graphical and biological elements. It is not only as a Professor at the Anhalt University of Applied Sciences in Dessau that I feel obliged to conduct research on and teach the Bauhaus doctrine—albeit not in the shape of antiquated appraisals and a nurturing approach. Teaching principles mapped out by Walter Gropius in 1922 have been interpreted time and again and adapted to the demands of differing periods. That which remains of Bauhaus in respect of which momentum Bauhaus could lend the architecture of the future should be examined anew again and again. In short, the question should be: how would we like to live tomorrow? Regrettably, the Bauhaus diagnosis—that modern education is segregated too much into individual disciplines, even in areas where research is dependent upon interdisciplinary and transdisciplinary approaches—appears to have remained unchanged. The discipline of Architecture, Facility Management and Geoinformation at Anhalt University of Applied Sciences still needs to explicitly state that its goal is to set benchmarks within education by interlocking the various disciplines of construction—thus implicitly stating that one core issue which Bauhaus sought to rectify is still pressing. For example, one of the greatest

challenges for those working within the university sector lies in willingness to cooperate and cross-link within a subject area, as well as between affiliated faculties within the university. Translating Gropius' teaching into the twenty-first century means adapting it to the current environment. As regards content, there are three factors which have radically altered our lives over the past twenty years: globalisation, digitalisation and conservation of resources. Universal solutions have thus far failed to emerge in order to tackle these areas of concern and challenges, or which would lend themselves to teaching. I have therefore set myself the goal within my teaching to impart to students five very broad, yet clear core competences within this frame of reference which facilitate both a holistic approach and a thorough examination of these topics. These are: perception, drawing, evaluation, preservation and marketing—in relation to areas of expertise covering design and implementation, construction and technology, history and theory. Although the main emphasis points of my teaching cover a broad spectrum, it is clearly targeted at the completed building or the completed room and will continue to be relevant even if these pressing problem areas were to be finally resolved today. Imparting and implementing these core competences within joint practical exercises is intended to make students more conscious of the architecture of the future.

The focus of our training lies on the space to be designed and on activities which need to be learned in order to be able to work at a high level. As Walter Gropius once said 100 years ago: "The ultimate goal of all artistic activity is construction!" In the same way I too would like to characterise my subject area of interior architecture as follows: "The goal of each and any teaching of architecture is the creation of high-quality surroundings." According to the common definition of the term, universities of applied sciences are

verschiedenen Disziplinen des Bauens verzahnt werden – womit implizit konstatiert werden muss, dass ein Kernproblem, welches das Bauhaus beheben wollte, immer noch akut ist. Eine der größten Herausforderungen bei einer Tätigkeit an einer Hochschule liegt daher in der Kooperationsbereitschaft und Quervernetzung innerhalb eines Fachs sowie zwischen angeschlossenen Fachbereichen innerhalb der Hochschule.

Gropius' Lehre ins 21. Jahrhundert zu übertragen bedeutet, sie den gegenwärtigen Rahmenbedingungen anzupassen. Inhaltlich gibt es drei Faktoren, die unser Leben in den vergangenen 20 Jahren radikal verändert haben: Globalisierung, Digitalisierung und Ressourcenschonung. Für diese Problembereiche und Herausforderungen haben sich bislang keine allgemeingültigen Lösungsansätze herauskristallisiert, die man als solche lehren könnte. Daher habe ich es mir in meiner Lehre zum Ziel gesetzt, den Studierenden innerhalb dieses Referenzrahmens fünf sehr allgemeine und doch klare Kernkompetenzen zu vermitteln, die einen ganzheitlichen Ansatz und die fundierte Auseinandersetzung mit diesen Themen ermöglichen: Wahrnehmen, Zeichnen, Bewerten, Bewahren und Vermarkten – bezogen auf die Kenntnisbereiche Gestaltung und Inszenierung, Konstruktion und Technik, Geschichte und Theorie. Die Schwerpunkte der Lehre sind zwar breit gefächert, dennoch zielen sie klar auf ein fertiges Gebäude beziehungsweise auf den fertigen Raum und werden auch dann immer noch aktuell sein, wenn heute akute Problembereiche endlich gelöst sein sollten. Die Vermittlung dieser Kernkompetenzen sowie ihre Anwendung in gemeinsamen praktischen Übungen sollen den Studierenden die Architektur der Zukunft bewusster machen.

Der Fokus der Ausbildung liegt auf dem gestalteten Raum und den Tätigkeiten, die erlernt werden müssen, um auf einem hohen Niveau arbeiten zu können. Wie Walter Gropius vor 100 Jahren sagte: »Das Endziel aller bildnerischen Tätigkeit

ist der Bau!«, so möchte auch ich für mein Lehrgebiet Innenarchitektur formulieren: »Das Ziel einer jeden Architekturlehre ist es, qualitativ hochwertige Räume zu schaffen.«

Laut gängiger Definition sollen Fachhochschulen durch praxisbezogene Lehre auf berufliche Tätigkeiten vorbereiten, in denen die Anwendung wissenschaftlicher Erkenntnisse und Methoden oder die Fähigkeit zur künstlerischen Gestaltung erforderlich ist. Dies beinhaltet in dem von mir vertretenen Studienfach auch die textliche Darstellung architektonischer Sachverhalte. Durch die konstante Publikation der Ergebnisse meiner Seminare gewährleiste ich eine kontinuierliche Begleitung meiner Lehrveranstaltungen. Die seit 2016 in Kooperation mit Archiven, Institutionen und wissenschaftlichen Einrichtungen erstellten Semesterdokumentationen des Lehrgebiets Innenraumplanung, in denen Themen aus Architektur und Denkmalpflege zweisprachig diskutiert werden und die auch online über die Hochschulbibliothek zur Verfügung stehen, dienen jedoch nicht nur der Sicherung von Seminarinhalten, getreu dem zwar fragwürdigen, aber leider immer noch aktuellen Motto vieler Studierenden, frei nach Goethe: »Denn, was man schwarz auf weiß besitzt, kann man getrost nach Hause tragen.« Vielmehr werden die Studierenden bei der Erstellung dieser Publikationen aktiv einbezogen, indem sie unterschiedliche Herangehensweisen an die Dokumentation als Archivierungs- und Kommunikationsmittel erarbeiten und fundierte Grundlagen der Öffentlichkeitsarbeit für Architekten erlernen. Im Endprodukt – der Publikation – werden sie namentlich in ihrer Funktion gewürdigt. Solcherlei vorzeigbare Veröffentlichungs- und Arbeitsnachweise sollen den Studierenden als ein erster Schritt in die akademische Welt oder freie Wirtschaft dienen.

Im Sinne eines ganzheitlichen Ansatzes in der Lehre gilt es die eigenen Fächergrenzen zu überwinden, um eingefahrene Pfade zu verlassen und neue Blickwinkel zu ermöglichen.

designed to prepare students to take up employment in occupations in which the application of theoretical knowledge along with associated methodology or being capable of artistic creativity is required—and to do so by means of practically oriented teaching. Within the field of study I represent this also includes the textual analysis of architectural issues—an area of expertise as it were. The continuous publication of research findings from my seminars ensures a robust accompaniment and support for my classes. Produced in collaboration with archives, institutions and academic establishments since 2016, semester documentation for the discipline of Interior Planning—in which topics from the fields of architecture and cultural heritage preservation are discussed bilingually and are also available online through the university library—serves not only to safeguard seminar content, being faithful to the motto of many students (which is undeniably questionable, but regrettably still topical), freely adapted from Goethe: "For what one has in black and white, one can carry home in comfort." Rather, students are actively engaged in the compilation of these publications by developing different approaches to documentation as an archival and communication tool and by acquiring a well-grounded basic knowledge of public relations for architects. They are accredited by name according to their contribution within the final product—the publication itself. Such tangible publication references and documentary evidence of previous work will equip students well as a first step into the world of academia or the free economy.

In pursuit of the holistic approach in university teaching it is essential to overcome one's own subject boundaries in order to desert the beaten track and open up new perspectives.

COOP Design Research COOP Design Research

Stephan Pinkau
Hochschule Anhalt

Regina Bittner
Stiftung Bauhaus Dessau

Wolfgang Schäffner
Humboldt-Universität zu Berlin

COOP Design Research – was ist das für ein Masterprogramm? Denkt man darüber nach, in den Entwurfsdisziplinen Architektur und Design zu promovieren, braucht man einen gewissen Vorlauf zur Abklärung und Selbstfindung. Man muss für sich herausfinden: Will man das, kann man das? Wie verläuft der Weg von der Gestaltung zum Schreiben über Gestaltung? Der Studiengang COOP Design Research stellt hierfür eine Brückenfunktion dar und versteht sich als Vorbereitung auf ein wissenschaftliches Promotionsstudium. Das einjährige Programm mit dem Abschluss »Master of Science« richtet sich an praktizierende Gestalter. Der Studiengang wird durchgeführt von der Hochschule Anhalt und der *Stiftung Bauhaus Dessau* in Kooperation mit der Humboldt-Universität zu Berlin. Er findet im Bauhausgebäude in Dessau statt.

Vorläufer und vorbereitendes Format dieser Kooperation von Bildungsmilieus für dieses Masterprogramm waren die *Bauhaus Lectures Dessau* 2006–2012, denn die interdisziplinären Grundlagen konnten nicht aus dem Stand heraus entwickelt werden. In dieser Serie von Vorträgen und Diskussionen wurde eine Bandbreite von Themen erschlossen. Diese bezogen sich auf die Bauhaus-Epoche, es ging um deren Aktualisierung und Anreicherung.

Das Masterprogramm COOP Design Research profitiert ebenfalls von dieser inspirierenden Einheit von Ort und thematischer Bezugsebene, denn die Studierenden lernen und arbeiten in einem Studio im Werkstattflügel des Bauhausgebäudes, und zwar in einem seiner schönsten Räume: mit Licht von zwei Seiten und ausreichend Platz für Ruhe und Konzentration. Die Erfahrungen im Bereich der Gestaltung, die die Studierenden in früheren Studiensemestern und in ihrer Berufspraxis sammeln konnten, dienen als Grundlage für eine nunmehr auf Forschung und Analyse konzentrierte Herangehensweise.

Mit der Einführung dieses Masterstudiengangs wird im Denkmal Bauhausgebäude erstmals seit dessen Schließung durch die Nationalsozialisten 1932 wieder eine Ausbildung im Sinne der berühmten Hochschule angeboten.

Weitere Informationen unter:
<https://coopdesignresearch.de>

COOP Design Research—what kind of a master's programme is that? If one thinks about doing one's doctorate in the design disciplines of architecture and design, one needs a certain amount of preparatory time for enlightenment and self-discovery. You have to find out for yourself: Does you want this, can you do this? What is the journey like from designing to writing about design? The COOP Design Research course provides a bridging function in this regard and sees itself as a preparation for scientific doctoral studies.

The one-year programme graduates with a 'Master of Science' and is aimed at practising designers. The course is run by the Anhalt University of Applied Sciences and the Bauhaus Dessau Foundation in collaboration with the Humboldt University of Berlin. It takes place in the Bauhaus building in Dessau.

The precursors and preparatory formats of this collaboration of educational milieus for this master's programme were the Bauhaus Lectures Dessau 2006–2012 because we could not develop the interdisciplinary fundamentals from scratch. In this series of speeches and discussions, a whole array of topics was opened up. These related to the Bauhaus era; they dealt with updating and enriching it.

The COOP Design Research master's programme also benefits from this inspiring unity of place and thematic reference level because the students learn and work in a studio in the Bauhaus workshop wing, that is, in one of its most beautiful rooms: with light from two sides and enough space for quiet and concentration. The experiences in design that the students were able to acquire in previous study terms and in their professional practice serve as the basis of an approach now focusing on research and analysis.

With the launch of this master's course, it will be the first time since the national socialists closed it in 1932 that an education in the sense of the famous college will be offered in the memorial Bauhaus building.

DESIGN THINKING

A REFLECTION THROUGH ITS ORIGIN, EVOLUTION AND (NON) DEFINITION

Author: **Rafaela Zeidler**

COOP Design Research

First Examiner: Prof. Dr. Joachim Krausse

Second Examiner: Christine Schnaithmann

(complete thesis including bibliography is available at HSA library)

1. An introduction to Design Thinking

The term Design thinking (DT) has been defined as a methodology, innovation technique, mindset and even a discipline, and such haziness around the concept triggers questions about its real value and contribution. It has been largely discussed recently and applied in a variety of fields, either by designers or not, provoking different reactions and opinions both academically and professionally. It is often presented as a process that delivers creativity and ultimately innovation to organizations and society through a problem-solving approach (Brown, 2008) and is also promoted through idealistic claims that place DT as the next competitive advantage (Martin, 2009). But all this noise encircling the topic also raises questions about its origin and authenticity, for instance being characterized as a public relations term for good, old-fashioned creative thinking (Norman, 2010) or even referred to as a failed experiment (Nussbaum, 2011).

Such a polemic resulted in an extensive exploration of the subject, that has been the central focus of many books (Brown, 2008, 2009b; Martin, 2009; Cross, 2011; Stewart, 2011), journals, conferences and symposiums (Rylander, 2009; Dorst et al., 2010; Smulders and Subrahmanian, 2010). The expansion of DT to sectors outside the traditional design practice, such as business and management, culminated in a growing popularity of the term, that has been considered a buzzword that is far from being precisely defined (Johansson-Sköldberg, Woodilla and Çetinkaya, 2013).

But despite the emphasis that this term has been gaining in the last decades, it is still considered as rather broad (Carlgren, Rauth and Elmquist, 2016) and there is a lack of common understanding among practitioners and scholars (Hassi and Laakso, 2011; Kimbell, 2011). The term is still extremely ambiguous and has a wide range of different descriptions. Along with that, once DT expanded to disciplines beyond the traditional field of design, new meanings and interpretations have constantly been attributed to the concept, as it moves through different contexts of practice. Hence, an exploration of its multiple definitions and characteristics is required in order to support its cross-disciplinary effectiveness, understanding the limits of its contribution and identifying the underpinned value. The thesis seeks to explore these different discourses, connecting and comparing knowledge produced both in theory and practice, reflecting upon their intersections and dissonances.

Design Thinking and its Ambiguity

Recently the term DT has been tied to the design consultancy IDEO (Brown, 2008, 2009b; Brown and Wyatt, 2010), assuming in the contemporary discussions a character much more related to a methodology that approaches complex problems in a creative way and delivers disruptive solutions. This peculiar feature represents an important strategic potential of DT to management and business innovation (Brown, 2009b; Martin, 2009; Verganti, 2009). The broad acceptance of this concept can be confirmed by the fact that many postgraduate courses in non-design related fields started to offer an introduction to DT, showing a growing attention for the theme also in education (Dunne and Martin, 2006).

Some theoreticians, however, argue that this contemporary DT approach represents “a prescriptive or even idealistic view, which is ultimately formulated at a rather low resolution level”, once the instructions are more a generalization of experiences in a management problem solving approach (Badke-Schaub, Roozenburg and Cardoso, 2010, p. 7). Evidence for these inconsistencies can be seen in the multiple meanings given by one of its main advocates, Tim Brown, that for instance characterizes the term as a “team-based approach to innovation”, a “discipline” (Brown, 2008, p. 86) and “part of a development process” (Brown, 2008, pp. 88–89).

But the history and evolution of the term DT are much more complex and started decades ago, with extensive research that was aimed at investigating the cognitive processes of designers (Lawson, 1980; Cross, 1982; Rowe, 1987; Dorst et al., 2010). This encompasses the identification and interpretation of particular competences and skills of designers, understanding processes, methods and the nature of design problems. This research was empirically based and the amount of different approaches to the field didn't allow for an integration of the theories, but instead a fragmentation.

This contradiction that follows the term, referring to a way of approaching innovation in the contemporary debates, while referring to the cognitive processes of a designer in the design research community has been the subject of much research (Hassi and Laakso, 2011; Johansson-Sköldberg, Woodilla and Çetinkaya, 2013). The common understanding reached is that DT evolution can be traced under two different discourses, a management (or contemporary) and design (or traditional) one.

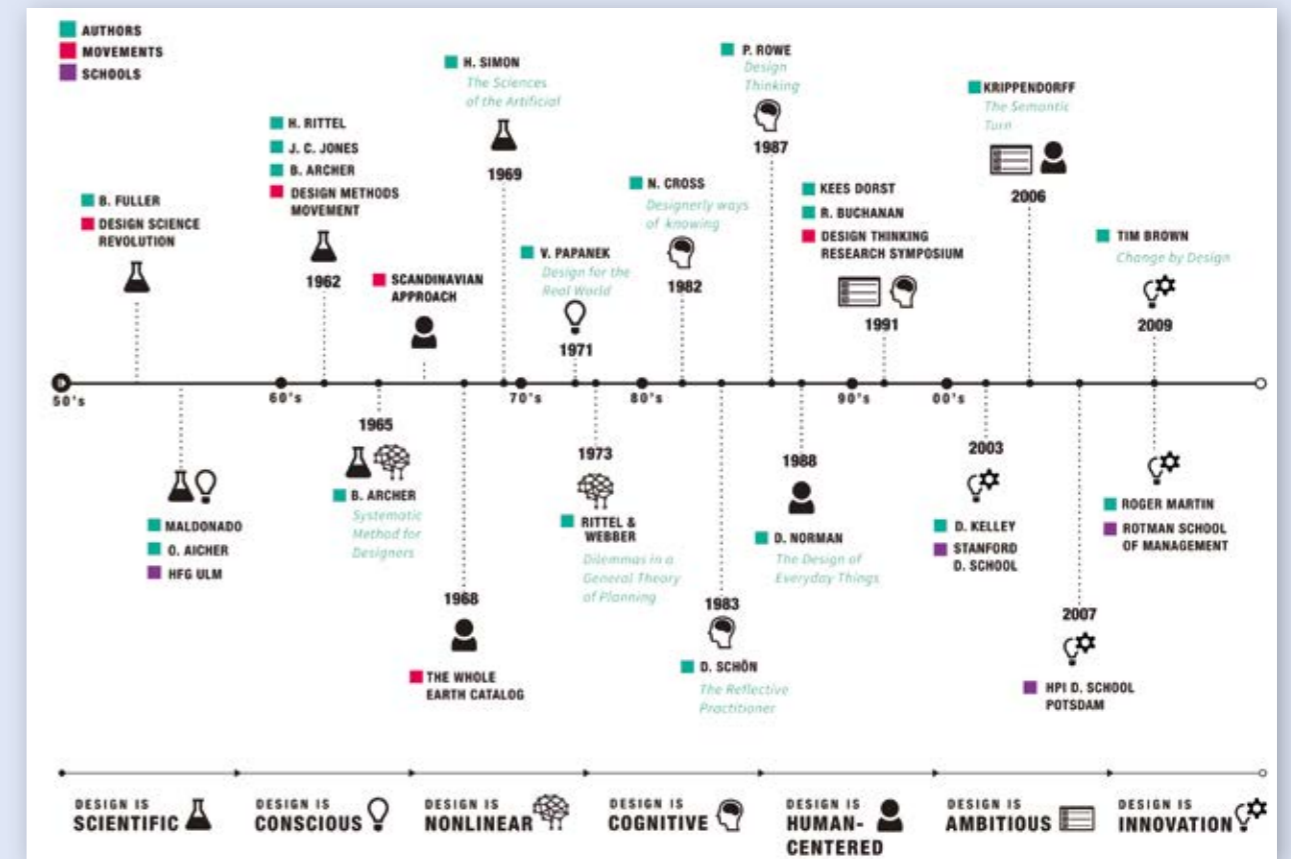

Diagram: Theoretical framework and literature review

The traditional discourse started in the early 50's and investigates the process behind the activity of designing, being often rooted in the academic field. The contemporary one emerged from recent managerial debates, and encompasses the practices of DT beyond the design realm and for professionals with and without a scholarly background in design.

Design Thinking and its Current Practice

The expansion of practice beyond the traditional design disciplines represents exciting possibilities to professional designers, that are now less associated to giving form to things and have started to play important roles socially, politically and economically, impacting organizations at different levels, engaging in complex social discussions and even acting as a “glue” (Kelley, 2005) in multidisciplinary teams. With this panorama shift, that situates design and designers “working in challenging new contexts, we must engage in discussions about the place of professional design in the world” (Kimbell, 2011, p. 286). This becomes particularly more complex once one of the main advocates of the contemporary discourse of DT points out that everyone with the right “aptitude” (Brown, 2008, p. 87) is able to solve any complex problem using DT (Brown, 2008, p. 92). This demonstrates another facet of the concept, that in the current practice is not seen as an activity reserved to the designer, but actually an accessible and useful tool that can be used by anyone.

Therefore, it is extremely relevant to understand how practitioners frame and perceive the potential impact of the concept, in order to evaluate to which extent it has been mostly used with a managerial bias, or actually seeks to make bigger contributions to society as a whole, as claimed by Tim Brown in his book “Change by Design” (2009b). Finding out how those who practice DT define the subject is essential to identify the challenges to reach a common comprehension of the term, and the perceived value to design and other disciplines.

Research question

Having set the scene, this thesis investigates the intersections and dissonances between the DT discourses, following a chronological path that emphasizes its evolution, not looking for a normative answer to what is it, but rather trying to identify and compare the key elements of DT in both theory and practice. The research question that directed this investigation is:

What are the key elements that constitute the concept of Design Thinking, and to which extent its discourses are related?



DESIGN THINKING

A REFLECTION THROUGH
ITS ORIGIN, EVOLUTION
AND (NON) DEFINITION

2. The System and Evolution of Design Thinking

The theoretical framework aimed at identifying the constellations in which the term emerged and trace its evolution within design theory, and when possible, also observe how it relates to big changes in society.

The chronological setting starts in the 1950's and goes until nowadays, and cannot be traced in a single path, as the discourses show continuity and discontinuity. The review is structured by clusters that represent the main idea of a certain period of time, that is not necessarily a well-defined decade, as the concepts were developed in an organic way. However, the order in which the information is displayed is chronological. Extracting the main expression of a timeframe allows to notice its influence over the consecutive paradigm. Furthermore, three main layers of sources were investigated: authors, schools/institutions, and movements. They have been chosen as a result of the strong impact that their ideas have had in the current practice of design as a discipline.

Looking not only for the widely referenced authors and movements that influenced DT's history, but expanding the research when necessary, consists of an attempt to uncover less accredited connections that had also contributed to the evolution of the term, and that perhaps can give some insights into the social, political and historical contextualization within the decades.

A set of theoretical characteristics of DT could be identified through the analysis of the theories intertwined to the evolution of the term. From a theoretical perspective, DT can be characterized as: problem-solving, experimental, human focused, interdisciplinary, collaborative, intuitive, an agent of change, and detaining its own knowledge. These eight principles are presented, following the same chronological distribution used in the literature review, and pointing out which authors, schools or movements are related to the identified concept. So, DT is a way to approach complex problems (Rittel and Webber, 1973) through a reflective practice (Schön, 1983), considering the user (Norman, 1990), to tackle intangible solutions (Buchanan, 1992).

3. Current Practice

To understand how the concept is perceived and applied by the professionals is essential in order to identify its dominant characteristics in practice. Two methodologies are used to explore the current practice around the term DT. The first one is the research *Framing Design Thinking: The Concept in Idea and Enactment*, conducted by Lisa Carlgren, Ingo Rauth and Maria Emlquist and published in the format of a scientific article in the *Creativity and Innovation Management* journal, in 2016. This research was selected mainly due to three factors: a wide data collection with 36 empirical interviews conducted inside six big organizations of different business, and that claim to use DT as a driver; the development of a framework with five themes that characterize DT in practice as a result; the updated data, that provides an analysis compatible with the current scenario of DT in practice. As

a complement, some extra interviews with experts were conducted to compare findings, opening an opportunity to identify patterns, and to get a more individual and in-depth points of view regarding specific questions that are relevant to this thesis.

The sampling was composed by four specialists, all familiar with the concept and with their own understandings and definitions. The educational background is diverse, for instance IT system, psychology and anthropology, but all pursued a design education at one point. This multidisciplinary background, complemented with also education in design, adds plurality and enriches discussions encircling the exclusivity of DT to the design field and its practice by non-trained designers. The profile of the companies where they work also adds an interesting perspective, covering a multinational company in the healthcare business, an international banking and financial services company settled in the Silicon Valley, one consulting with emphasis in brand strategy and innovation, and another in user experience. The specialists are from United States, Netherlands and Brazil.

The data gathered from the interviews was clustered and confronted with the framework proposed by Carlgren et al. (2016). The seven principles that emerged from the analysis describe DT in the practice as: *problem-solving, iterative, user focused, mutable, plural, a navigation tool and a culture.*

4. Intersections and dissonances

Some scholars defend that there is a lack of connection between the traditional and contemporary discourse of DT (Badke-Schaub, Roozenburg and Cardoso, 2010; Johansson-Sköldberg, Woodilla and Çetinkaya, 2013; Carlgren, Rauth and Elmquist, 2016). However, through the analysis and comparison of theoretical and practical principles, it is possible to see intersections among them. Some concepts evolved, but remain consistent across contemporary definitions.

A very common description of DT in the contemporary discourse relies on: a *creative problem-solving* approach with an *iterative process*. By breaking this description down, it is possible to analyze on a deeper level what the underpinned values are. First, the description of design as a problem solving practice is nothing new, and despite the generalization of it, as many professions are on some level solving a problem or improving a solution, this subject was already extremely explored in design theory. When Archer (1965) suggested that design problems are complex, and Rittel and Webber (1973) deeply investigated the nature of them, this inherent condition of the practice was already a common sense. The theory of *wicked problems* explicitly called for a nonlinear design process, in order to deal with such complexity intertwined with the essence of design problems, that as described, are ambiguous and mutable, with not only one possible solution. The experimental approach that explores multiple solutions at the same time, suggested by the aforementioned theory, relates pretty much to the current description of a necessity to be comfortable with complexity and ambiguity

THESIS FRAMEWORK

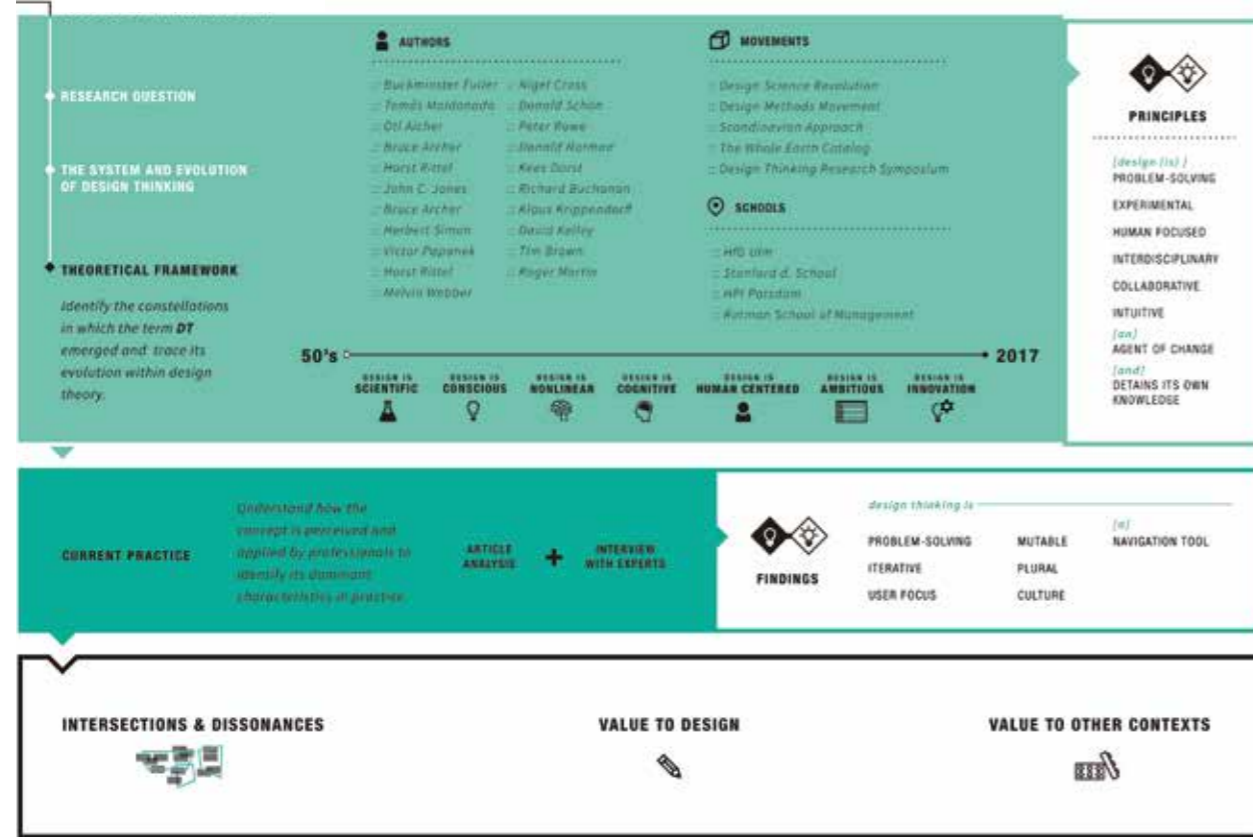

THEORETICAL PRINCIPLES

DESIGN IS:	SCIENTIFIC	CONSCIOUS	NONLINEAR	COGNITIVE	HUMAN-CENTERED	AMBITIOUS	INNOVATION
PROBLEM-SOLVING	ARCHER (1965)	PAPANEK (1984)	RITTEL & WEBBER (1973)	SCHÖN (1982) CROSS (1982) ROWE (1987)	NORMAN (1988)	BUCHANAN (1992) KRIPPENDORFF (2008)	BROWN (2009) / MARTIN (2009) / H.P.I. / D.SCHOOL / ROTMAN SCHOOL OF MANAGEM.
COLLABORATIVE	FULLER OTL AICHER MALDONADO	PAPANEK (1984) HFG ULM			NORMAN (1988) / WHOLE EARTH CATALOG (1968) / SCANDINAVIAN APPROACH 60'S		BROWN (2009) / MARTIN (2009)
INTERDISCIPLINARY	FULLER SIMON (1960) ARCHER (1965)	PAPANEK (1984)		SCHÖN (1982) CROSS (1982)	NORMAN (1988)	BUCHANAN (1992)	BROWN (2009) / MARTIN (2009) / H.P.I. / D.SCHOOL / ROTMAN SCHOOL OF MANAGEM.
INTUITIVE		PAPANEK (1984)		SCHÖN (1982) CROSS (1982) ROWE (1987)			
HUMAN FOCUSED	ARCHER (1965)	PAPANEK (1984) HFG ULM			NORMAN (1988) / WHOLE EARTH CATALOG (1968) / SCANDINAVIAN APPROACH 60'S	BUCHANAN (1992) KRIPPENDORFF (2008)	BROWN (2009) / MARTIN (2009) / H.P.I. / D.SCHOOL / ROTMAN SCHOOL OF MANAGEM.
EXPERIMENTAL			RITTEL & WEBBER (1973)	SCHÖN (1982) CROSS (1982) DORST (2011)	SCANDINAVIAN APPROACH 60'S		BROWN (2009) / MARTIN (2009) / H.P.I. / D.SCHOOL / ROTMAN SCHOOL OF MANAGEM.
AGENT OF CHANGE	FULLER ARCHER (1965) SIMON (1960)	PAPANEK (1984) OTL AICHER HFG ULM				KRIPPENDORFF (2008)	BROWN (2009)
HAS ITS OWN KNOWLEDGE	FULLER ARCHER (1965) SIMON (1960)			CROSS (1982)			

given by the ongoing practice. However, the current focus on *reframing* the initial problem as a constant and essential task in the design process, attempts to go further and understand the roots of the problem, opposing Papanek's argument that designers don't really understand problems in depth. Perhaps, the link with creativity (also used to describe the current DT discourse) relies particularly on the word *reframe*, as it brings ideation to the very beginning of the process, by constantly generating new alternatives to formulate the initial problem. Furthermore, creativity can also denote the organic way in which the design process is approached, leading to the second part of this analysis, the largely applied expression: *iterative process*. Grounding on descriptions such as convergence and divergence and a learning-oriented process, it is clear the relation with the *reflective practice* theory developed by Schön (1983). An interesting fact though, is that Schön acknowledged the inherent role that intuition plays in this constant internal dialog and learning-by-doing process, but this is not emphasized in the current practice of DT. Schön also highlighted the development of a framework as a core practice common to all design disciplines, and that is definitely something that DT explores nowadays. With a vast toolbox and techniques to support, these frameworks have very specific stages and practices related to them, consisting of almost a how to design manual. Having a structure of work might be important, but it is essential to delimitate the borders between structure and limitations. The process claims to be iterative, or nonlinear, but follows a strict framework, putting a very well-defined boundary to the exploration. Often the framework's stages must fit in an extremely delimited period of time (usually the timeframe of a workshop), so the breakthrough ideas must come not only while following the precise framework, but also within a defined timeframe. It seems extremely challenging to have an unconstrained thinking when so many parameters are set. Dorst (2011) argues that designers think through the process of trying out different possibilities, and building a repertoire of experiences that guide them to develop an intuition of what might work in the problematic situation. The thinking in the design is intrinsically related to exploration and intuition. The frameworks must be carefully interpreted, as not to represent an alternative linear form of practice, but to give space for a change in the way the understanding is applied, and allow the generation of new possibilities as the process goes through. By taking this perspective into account the repetitiveness and predictability might be reduced, and perhaps intuition can play a more important role in the practice, opening space for serendipity. Together with the toolbox, the framework cannot play such an important role, restricting the creative development and replacing the thinking of a designer, they must aid the process and support the in-depth exploration, rather than guide it. Both must be designed to the process, and not the opposite. These two important characteristics of the current practice, *problem-solving* and *iteration*, are directly related to the paradigms identified in the evolution of the term (design methods and cognitive investigations). The rational problem-solving from Simon (1969), contrasts with the reflective practice of Schön, in the same way

the current iterative process contrasts with the structure conceived to deliver it. The human-centeredness is also nothing new. Being tackled by different perspectives in diverse theories, this concept that was highlighted by some, before Norman further developed and spread it, receives a central attention in the current practice. However, nowadays a special emphasis is given to the word *empathy*, that is almost a requirement in order to become a *design thinker*, and highlighted as fundamental to design better solutions (Brown, 2008). Badke-Schaub et al. (2010, p. 7) defend that empathy is always biased by a person's own perceptions, experiences and mental models. The tacit knowledge of a designer plays a fundamental role in this "empathizing" condition. Added to that, the understanding of the needs and pains of a user in depth consists of a blurred terrain, as users themselves may not be clear about what they want. By attributing to a designer the figure of a translator, it actually places the designer in the center of the process, obtaining a designer's version and interpretation of what the user need. Regardless, the traditional design often taught does not train the professional to have ethnographic skills, that must take into consideration a wider frame of factors in order to have a contextual perspective. Recently, the user-centered concept evolved to co-creation (that actually has its roots in the Scandinavian approach, back in the 60's). By inserting the user as part of the process, the designer shifts from a translator/interpreter to a mediator. It represents an ambitious propose, but that seems more coherent to the core of the concept than just speaking by the user. An important factor in this new panorama is the fact that DT in the contemporary discourse is defended as possible to be practiced by anyone, not necessarily trained designers. If the design process is based on exploration and intuition, and empathy is based on tacit knowledge, then in the context of co-creation all these factors influence directly how the process with the user is conducted, and therefore the output. But what happens when professionals with different mental processes and tacit knowledge execute the co-creation practice? And how does it differ from the designers' process? It is necessary to deeply understand the entangled relation between empathizing and co-creation, and how the different professional backgrounds interfere in this condition, allowing the real contribution of empathy to the DT process to be perceived. The aspect of collaboration, strongly present in the current practice, draws under two main layers, the first with-in teams composed by a plurality of professionals, and the second relies on the bridge that DT builds with other fields. This characteristic matches the history and evolution of the concept, that showed the designer as a natural synthesis of distinct professionals that is influenced and influences different disciplines. The role of the designer in the current practice of DT is much more related to a facilitator, a description that Papanek had already attributed, when he stated that designers often must act as a communication bridge between the team members (Papanek, 1984). Operating on such a level of multidisciplinary, the designer must design the social interactions of the processes for different contexts. It is not about designing complex solutions that might or might not be tangible, now it is

about developing the social construction of the process. The designer must be able to perform in environments of diversity, and be able to bring professionals educated or not in design together, and conduct the designed process. But this new required skill does not fit in every designer's profile. Also, not every designer necessarily must be a design thinker. However, the discussion is way broader than only considering designers and non-designers, it actually requires a step back, and look to what the essential features are required to perform this kind of activity, and how the design education can fill this gap. Design is a process that engages individuals, collaboration and social processes per se, and particularly in the current practice of DT, to understand the value that the designer brings to multidisciplinary contexts is a fundamental issue.

5. Value to Design

The term Design Thinking allows an interesting exploration. Design, according to Simon (1969) is the transformation of an existing condition into a preferred one. This metamorphosis draws a line from the present state to the future state that must be created and shaped, meaning that it consists of more than just changing, it is also making. The word making in the DT context does not relate to the physical action, but rather to an enabler of the transformation that is intrinsically related to the future. This concept dialogues with the abstract levels in which DT can operate, within the most diverse contexts and interdisciplinary spheres. DT as a tool of transformation and with its capacity to reach a broad range of terrains became almost a language.

The potential of DT to be a communication tool relies on some values intertwined with the practice, such as the systematic comprehension of all the stakeholders, business and end-users. Designers, as facilitators, can navigate between different constellations of knowledge, creating an alphabet to connect with different professionals and disciplines. This was precisely the skill that Papanek referred to and what HfG Ulm tried to do while training the students closely with specialists' teams. Maybe this is a natural characteristic of the designer, but what the current discourse of DT does is to explore it in an exponential way and reshape the dynamics of practice. However, the trap in exerting this new role is a possibility, as the risks of integrating knowledge from different sources might result in the loss of its own body of knowledge and culture. In order to avoid this, a common understanding of DT is required, that relies more on comprehending the culture of the practice and principles involved than a description to the term that might restrict the practice to a framework. By comparing the general principles of design as a discipline to the most known and applied framework of DT, it is possible to identify an overlap between the practices. The design disciplines encompass five main activities: formulating, representing, moving, evaluating and managing (Dorst, 2011). The framework of Stanford d. School describes DT also in five steps: empathize, define, ideate, prototype and test. Basically, different concepts are used to describe the same actions. Therefore, DT can be

interpreted as a domain of the design practice, and even if it shares knowledge with other disciplines, its essence is grounded on design. Perhaps DT is a framed version of design, with an integrative bias, that aims at building bridges between different practices and open to a non-design audience.

It is undeniable that design has now become a central figure to innovation, breaking away from the tradition link of the profession with pure aesthetic and function aspects and building a larger terrain of possibilities to act and impact. Design as a discipline is constantly expanding in meanings and connections, revealing unexpected dimensions in practice and understandings (Buchanan, 1992). DT demonstrates the design's potential and capacity to expand and tackles different spheres of practice, such as management. It is a framed way to transfer design principles to other audiences and, therefore, elevate the importance of the design discipline as a whole. It is a way to make design comprehensible and highlight its significance outside the traditional fields.

6. Value to other contexts

The explorative character of the DT process allows for constant new understandings and possibilities by questioning the briefing even before starting to solve the problem. This open end searching and forward looking represents an opportunity to question and shift paradigms. Aicher believed that designers are not only influenced by other disciplines, but also that social, cultural and political frameworks play an essential role in the decision-making processes. Fuller believed that design should overcome social and environmental problems, and Papanek, with a more emphatic point of view, shared partially the same purpose. Recently, Brown addressed the current practice as a way to improve not only organizations, but society, by delivering innovation. It is undeniable that the perception of design as an agent of transformation moves towards a better society. The evolution of DT showed that the concept followed all the paradigm shifts, answering to societal changes and being a tool for transition. By navigating and creating dialogs within different disciplines, the designer can bridge the rational and creative worlds, reframing the questions and expanding the possibilities. The "what it" is more than a design fiction tool largely applied in the DT practice, it is actually a tool to question the status quo and create new possibilities for the future. DT definitely cannot solve all the social, political and environmental problems, but can aid to start posing the right questions and guide to more assertive decisions.

If the practice of DT aims at making a contribution to other contexts, it is fundamental to understand the different constellations in which the practice will take place, and involve them in a dialog to understand specific criteria that must be taken into consideration to an efficient practice. Furthermore, if it integrates knowledge from other disciplines, such as management and ethnography for instance, they also must be involved in conversations to find a common ground and build a structure of practice. The design should conduct and design the processes and social interactions, but with inputs from other fields, to validate

and guarantee a cross-disciplinary effectiveness. The principles of DT that relate to design theory were already identified in this thesis, but equally important is to identify the set of characteristics that can support this mediation with other disciplines. As Cross defined, it is a challenge to create an interdisciplinary discipline of design (1999, p.7). It also noteworthy to DT, as it needs to be solid and clear enough to be consistent, yet flexible enough to transit between another fields. The blurriness that surrounds the term opens space for ambiguity, yet the search for a definition is considered counter-productive. The attempts to define it can lead to either a restrictive perspective of just one context of practice, with an established framework, or a very abstract definition that does not really represent the value and reality of practice. However, an identified challenge in practicing DT in other contexts is to guarantee its efficiency when there is no common knowledge about the concept, resulting in a difficulty to come up with the real potential of it.

How can the concept be kept consistent when it permeates so many different fields of knowledge and practitioners with their own interpretations and adaptations? It must be flexible in its application, but solid in its foundation and perceived value. Perhaps, rather than a discipline, mindset, methodology, mental model, it should be a set of principles, inspired by different disciplines, grounded on design discipline and spread throughout the world.

So far DT can be interpreted as a framed version of design, that can be translated to other disciplines and practiced by different professionals. Maybe that is precisely its biggest contribution. It is a way of understanding design, a way to disseminate the design culture to environments that expand the borders once imagined. Is a way to teach and apply design outside the design realm.

7. Research contributions

The theoretical principles identified through the chronological analysis characterize DT as a problem-solving, experimental, collaborative, interdisciplinary, intuitive and human focused concept. Moreover, it is also an agent of change that detains its own body of knowledge. These principles capture the essence in which DT is theoretically grounded, that is a result of the influence from different authors, schools, movements and social contexts. Throughout the investigation was possible to notice a strong relation between the theories, that influence the development of a continuity in research, or a paradigm shift. The scholars reference and confront ideas from each other, building a thread of integrated knowledge, even with opposite theories. The same behavior was not identified in the current literature of DT, in which no previous knowledge is taken into account to propose a new conception.

The theory of *wicked problems* (Rittel and Webber, 1973) and the *reflective practice* (Schön, 1983), together with the investigation of human-centered design lead by Norman had a large influence on shaping the way DT is promoted nowadays. The interdisciplinary aspect that was a theme mainly tackled by Archer, Fuller,

Maldonado, and Papanek also plays a fundamental role in characterizing the ongoing practice of DT.

The evolution of the term is reflected in the current practice, that describes DT as an approach that requires both an analytical and creative mindset. The roots of DT emerged in the design methods movement, followed the research shift to the cognition period and reached immaterial solutions. This brief history of the term evidences how the concept nowadays encompasses all the shifts that occurred in its development.

What the concept of DT represents to the ongoing practice can be described by seven principles: problem-solving, iterative, user focus, plural, mutable, culture and a tool for navigation. Most of these characteristics relate to the theoretical ones. This pattern shows that the traditional and contemporary discourses are not fragmented, but actually linked by the principles, that describe the essence of DT. Comparing with the previous discourse the contemporary one shows few dissonances, that rely mostly on the evolution of the concepts to make them fitter into different contexts of practice. Hence, the contemporary discourse is not a novelty, it is just a new way to present principles that are entangled to the core of design theory.

DT can be considered as a practice grounded on design discipline with an integrative bias that builds connections with other fields. The diversity of contexts that DT has been practiced enhance the value of design discipline by transferring its principles to different fields of knowledge. DT became a framed version of design, translating its essence into a model that is accessible to a non-design audience. It is a disseminator of design culture.

The identification of principles and the reflection upon the intersections and dissonances of the discourses allowed to visualize the characteristics detached from current claims and promotions, and to create a more integrated picture of DT in theory and practice. It does not give a definition of what is design thinking, but highlight the essence that constitutes the concept. This new perspective gained allow the comprehension of the underpinned value of DT to both design and other contexts. A common understanding of DT is still necessary to guarantee its efficiency in multidisciplinary practices. Although, this definition should offer an understanding of the principles and the culture of practice, rather than trying to establish a rigid structure. This thesis attempts to define DT more in terms of the essentials of the concept and less about techniques regarding the practice.

8. Final Considerations

DT can be a way to approach complex problems (Rittel and Webber, 1973) through a reflective practice (Schön, 1983), considering the user (Norman, 1990), to tackle intangible solutions (Buchanan, 1992); or, can be an iterative process for problem-solving, taking into consideration the human perspective and working in multidisciplinary teams (Brown, 2009a). But definitely, it should be a tool to question the status quo and change paradigms to a desired state of affairs



Gasse in Maskat, Oman.
Zeichnung: Matthias Höhne

Projekte

Masterstudiengang
Architektur

Bachelorstudiengang
Architektur

Student Projects

Master Degree Programme
Architecture

Bachelor Degree Programme
Architecture



Die Nominierungen der Preise erfolgt durch die Lehrenden. Eine Jury beurteilt und prämiiert die ausgewählten Arbeiten.
The lecturers nominate the prizes. In a second step a jury assesses and awards a prize to the selected works.

Auszeichnungen Faculty Awards

Mit dem **Robert-Oxman-Preis** werden die besten Thesis-Projekte eines akademischen Jahres ausgezeichnet. Namensgeber ist der israelische Architekt, Bauhistoriker und Architekturtheoretiker Robert Oxman, Professor Emeritus am Israel Institute of Technology. Oxman ist Autor zahlreicher Publikationen zu den Themenbereichen Designforschung und Computergestütztes Entwerfen.

The Robert Oxman Prize honours the best thesis projects of an academic year. The prize's namesake is the Israeli architect, building historian and architecture theorist Oxman, professor emeritus at the Israel Institute of Technology. Robert Oxman is the author of numerous publications about design research and computer-aided design.

Der **Lars-Lerup-Preis** wird an herausragende Projekte des ersten Studienjahrs vergeben. Der schwedische Architekt und Stadtplaner Lars Lerup (geb. 1940) ist Professor für Architektur und emeritierter Dekan an der Rice School of Architecture in Houston sowie Professor Emeritus der University of California in Berkeley. 2001 wurde ihm von der Universität Lund in Schweden die Ehrendoktorwürde verliehen.

The Lars Lerup Prize is awarded to outstanding projects of the first course year. Swedish architect and town planner Lars Lerup (born in 1940) is a professor for architecture and a dean emeritus at the Rice School of Architecture in Houston, TX, as well as a professor emeritus of the University of California in Berkeley. In 2001, the University of Lund in Sweden bestowed an honorary doctorate on him.

Der Förderpreis **Wettbewerbe Aktuell** wurde erstmals im Sommersemester 2019 an Studierende des Masterstudiengangs Architektur vergeben. Der Jury gehörten Vertreter des Fachbereichs sowie Thomas Hoffmann-Kuhnt, der Herausgeber der Architekturfachzeitschrift *Wettbewerbe Aktuell*, an.

It was the first time that students of the master's course in architecture received the Wettbewerbe Aktuell promotional award in the 2019 summer term. The jury was composed of faculty representatives and of Thomas Hoffmann-Kuhnt, editor of the Wettbewerbe Aktuell architecture trade journal.

Mit dem **Deutschlandstipendium** werden Studierende der Hochschule Anhalt für ihre besonderen Studienleistungen geehrt. Mit diesem Stipendium fördern Unternehmen, Stiftungen und Privatpersonen gemeinsam mit dem Bund Studierenerfolg und Engagement.

The Deutschlandstipendium represents a scholarship culture supported by the Federal Government, universities and private sponsors.

Robert-Oxman-Award

2018
 Tian Jing Lim (1st Prize)
 Rajani Singh (2nd Prize)
 Rumi Singh Maharjan (3rd Prize)

2019
 Mariia Shelkovska (1st prize)
 Oksana Chebina (2nd prize)
 Barbara Pomilio (3rd prize)
 You Soh Shing (Honorable Mention)

Lars-Lerup-Award

2018
 Oksana Chebina (1st Prize)
 Lizzette López Martínez (1st Prize)
 Wan Yee Chong (3rd Prize)

WS 2019

Gjiltine Isufi (1st prize)
 Yong Fui Kium (2nd prize)
 Delta Gomez (3rd prize)

Wettbewerbe-Aktuell-Preis

SS 2019
 Tobias Rümmler/Markus Passek
 Nathalie Feist
 Janet Landwehr

Deutschlandstipendium 2018/19

Randell Campbell
 Noora Dahham
 Janine Leonie Kübler-Buchegger
 Anastasia Lakrisenko
 Jinyi Oh
 Oskar Schmid

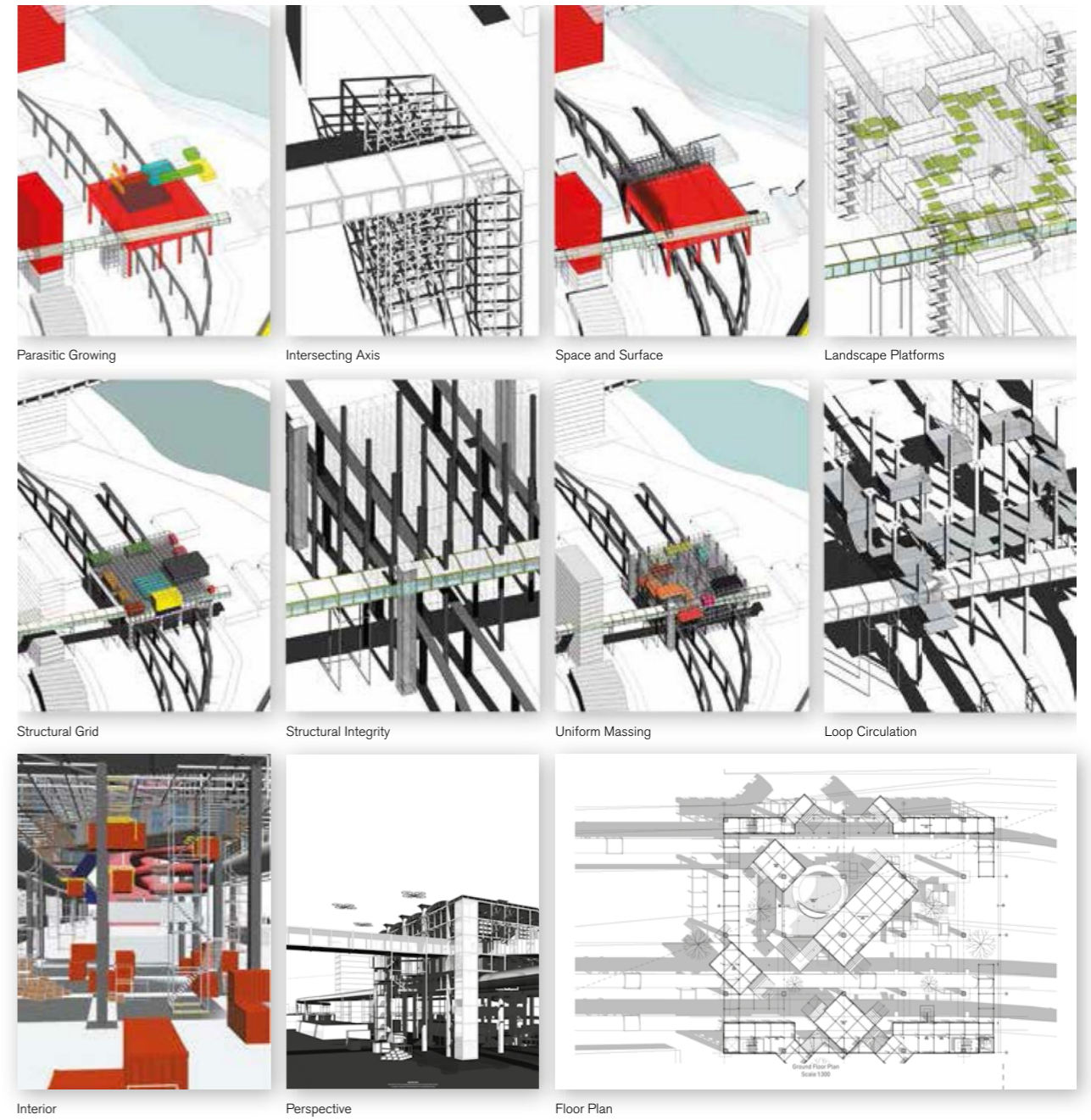
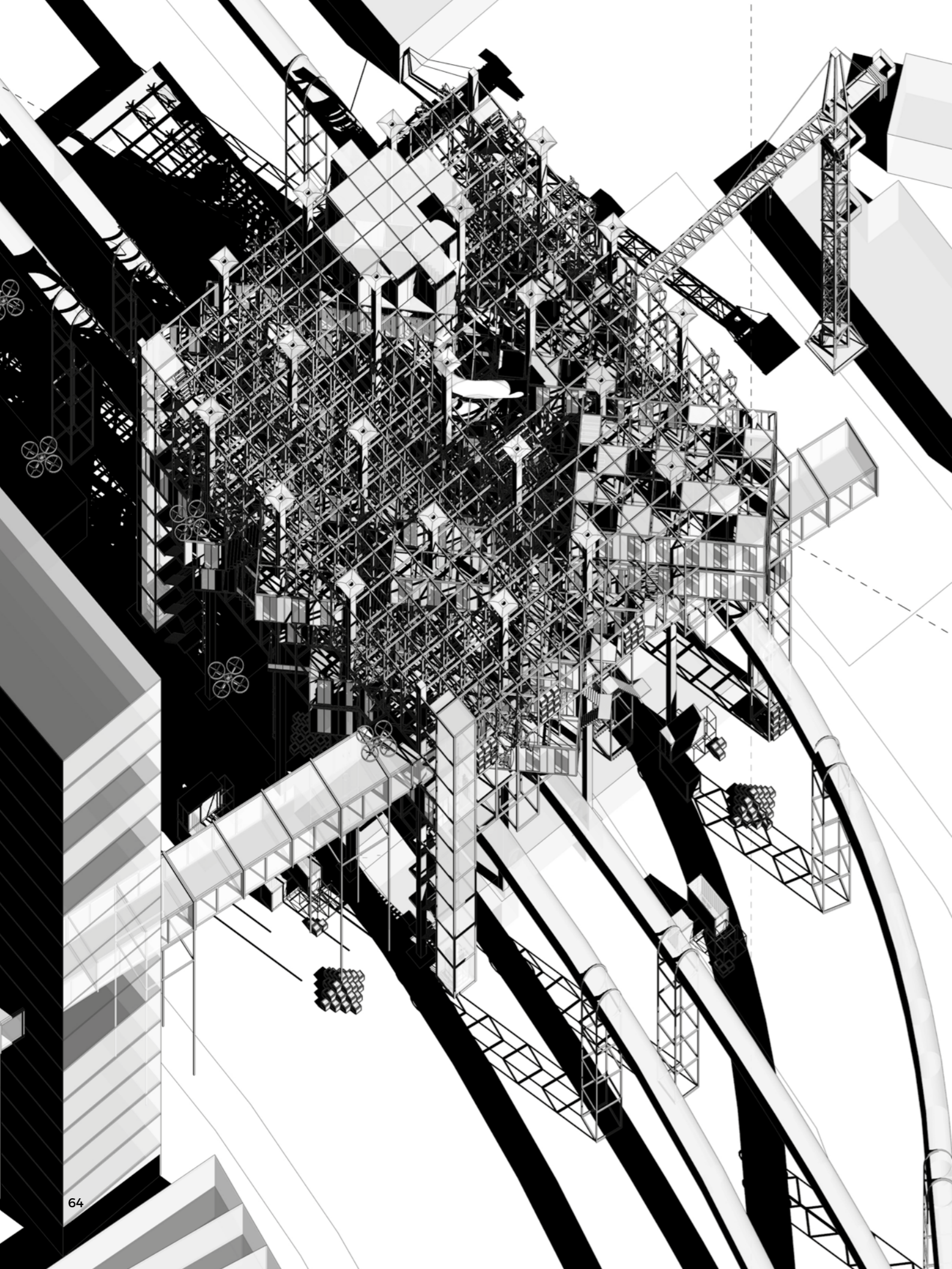

BAUHUB 2049
ROYAL KLANG TOWN, MALAYSIA

Gary Chong Wee Ming
DIA Master Architecture Thesis WS 2019
Supervisor: Ivan Kucina, Dulmini Perera

BAUHUB 2049: Manifesto of Future Design Educational. Hub through flexible design to support research and development of sustainable energy. BAUHUB is derived from a combination of two words »BAU« referring to the Bauhaus, also defined by construction in the German language. »HUB« meaning a platform for collaborative environment. The project is to speculate and form a hub for design education for a group of 30 students and three professors, which changes every semester in the year 2049. The hub will be where students collaborate with local craftsman and innovate by combining existing technology with design expertise to envision a better future. The hub will essentially be a catalyst which efficiently harnesses environmental energy from clean renewable resources, such as solar, wind and water, to power existing infrastructure.



Prinzenbad reloaded: Subterranean swimming hall between landscape and architecture



section



Second floor



Ground floor

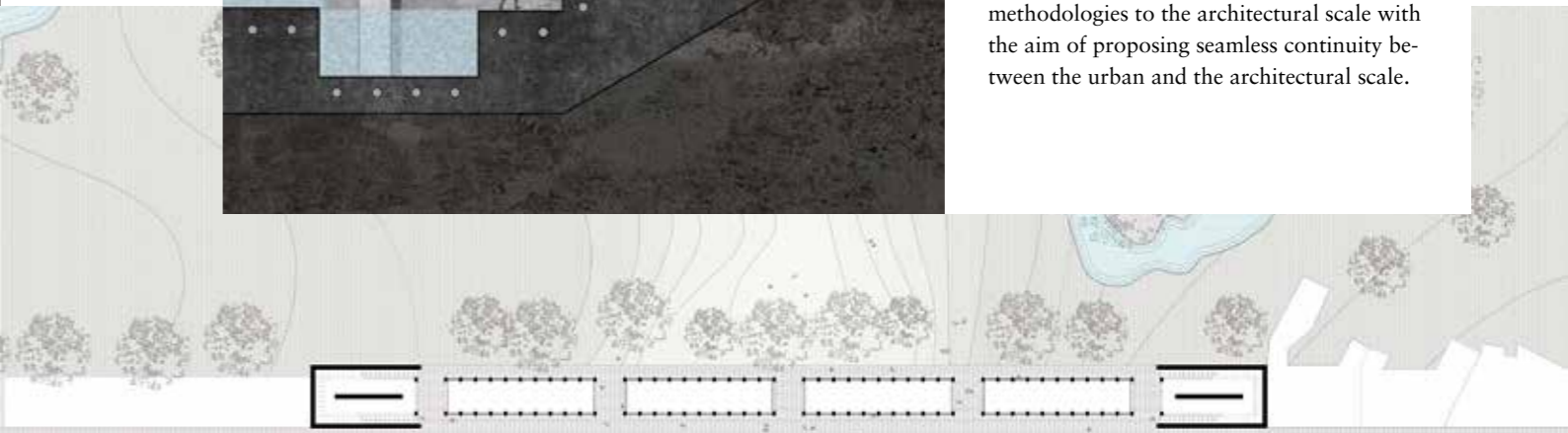

OPEN ACCESS 24/7

Mariia Shelkovska

DIA Master Architecture Thesis SS 2019

Supervisors: Antje Buchholz,

Roger Bundschuh

Bridging the gap between urbanism and architecture toward a new commons. The famous *Nolli map* defines public space as a spatial continuity, freely accessible to all. Yet it also postulates both a mainly horizontal space as well as one steeped in hierarchy and privilege. Since the 1960s, the idea of public space has been the subject of broad public and social debate about the idea of commons, pertaining not only to space and property, but more generally to the ownership of public and common goods. Within this debate, it is interesting to see that public space is often treated as a finite resource, on a par with natural resources such as fossil fuels. Population growth and increased densification lead to a supposed «shortage» of this horizontal resource. Yet new projects and debates propose sharply different scenarios of growth and opportunity around the concept of verticality and public space. At the same time, the spaces most commonly found in verticality tend to be ones of privileged access, spaces of select and limited public character. We will be examining and postulating true public spaces, of radical 24/7 accessibility and great conceptual stringency.

The thesis project will engage in this debate and propose strategies and solutions for a variety of specific sites in Berlin. Programs will develop from the analysis of the social, political, economic and architectural context of the chosen sites. We will be applying urban strategies and methodologies to the architectural scale with the aim of proposing seamless continuity between the urban and the architectural scale.



OPEN ACCESS 24/7
 AGORA – A SPACE FOR CONSTRUCTION OF COLLECTIVE MEMORY, BERLIN

Johan Andres Rey Sanchez
 DIA Master Architecture Thesis SS 2019
 Supervisors: Roger Bundschuh,
 Sebastian Ernst

Agora is a space for knowledge, discourse production, heritage and cultural preservation, open to people of all nationalities and backgrounds the world over. This is a place for the construction of collective memory, especially for immigrant inhabitants of Berlin. This includes all persons who have left their native land, of their own free will or not, to seek a better future: exiles, refugees, expatriates, and émigrés and all the ethnic groups that were persecuted throughout history.

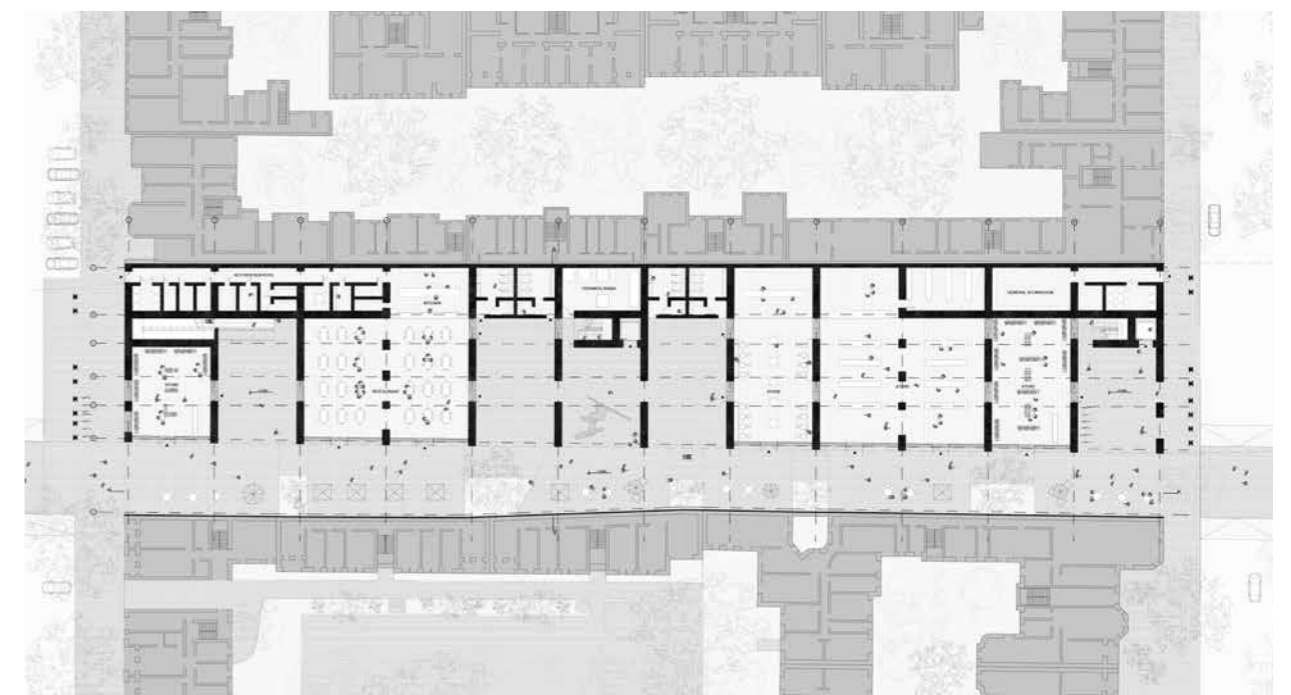

PENANG

Quality of Preservation and Progress
Tuning Lin / 4095295

2095

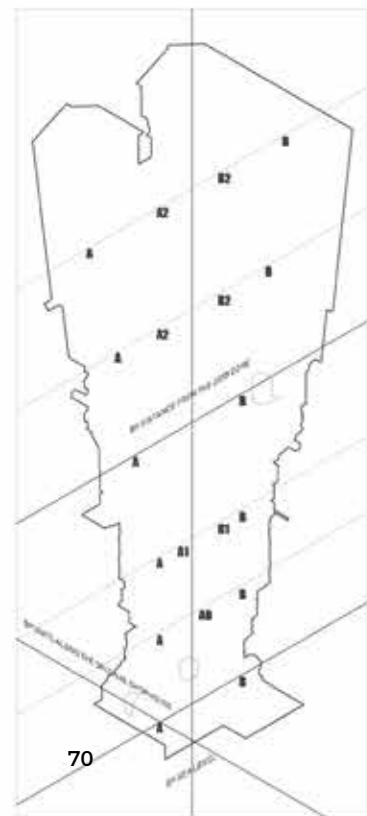
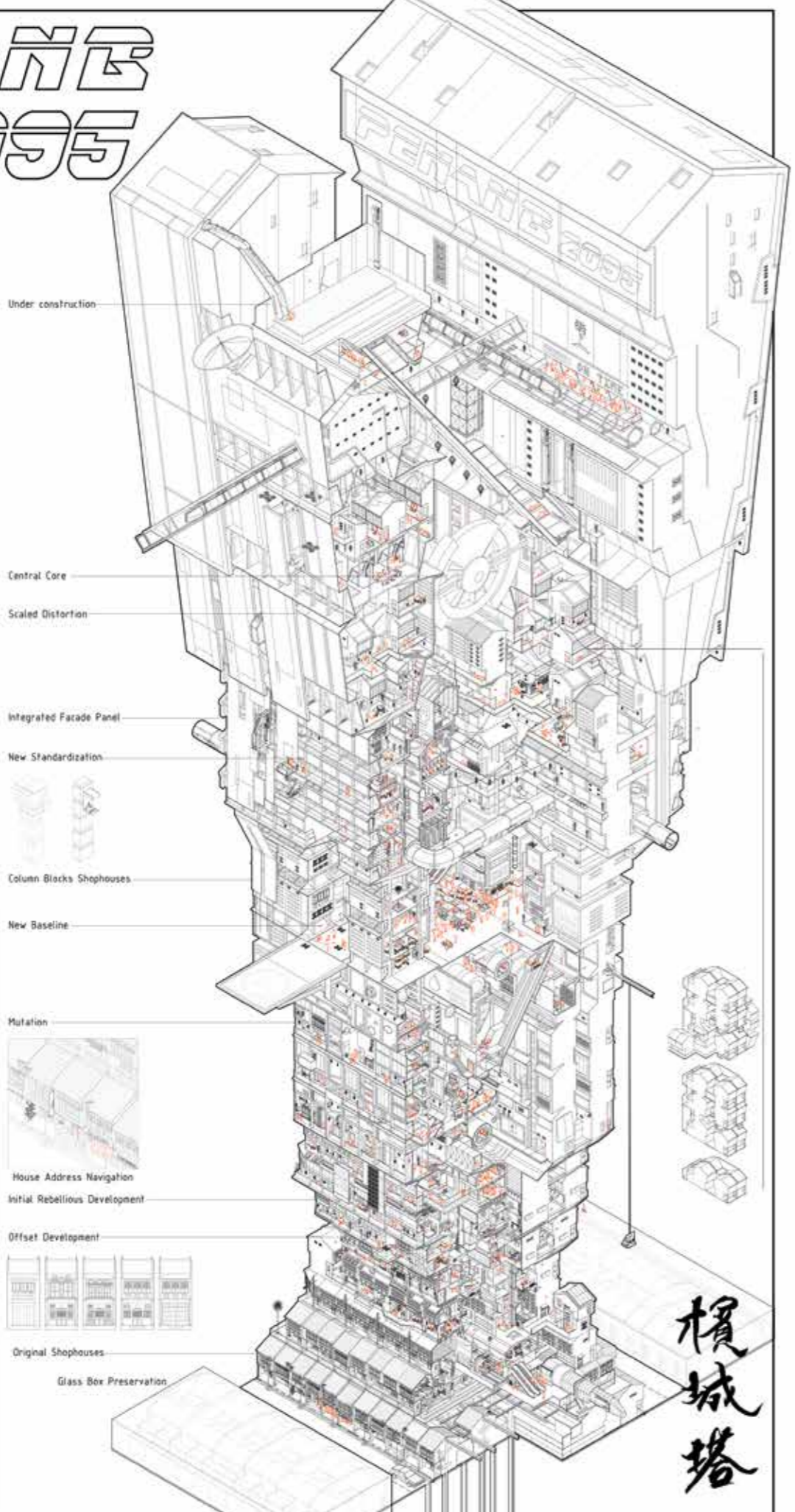
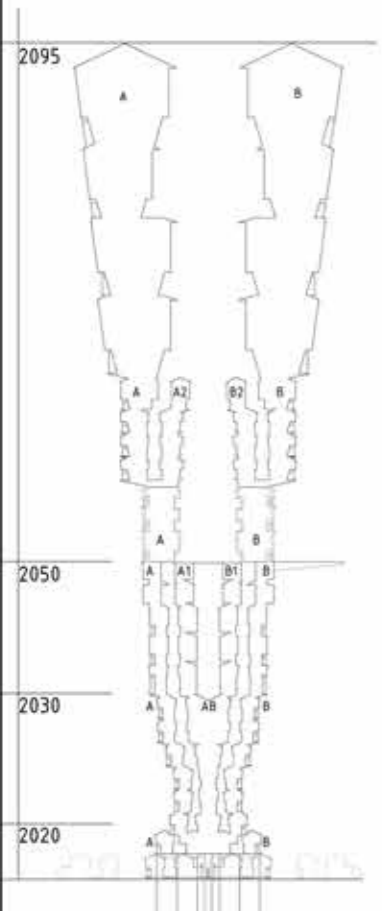

檳城塔

CONJECTURES TRIAL AND ERROR

Tian Jing Lim
DIA Master Architecture Thesis SS 2018
Supervisors: Prof. Dr. Jasper Cepl,
Ivan Kucina

*Winner of "Drawing of the Year 2018",
Arkitektskolen Aarhus*



A design that addresses the question of preservation in the urban building culture and heritage and in the architecture of the future. It looks like a growing tower, a factory, but when you move closer, urban life is revealed. It is a vertical village based on a reading of the existing organisation and layout of the city structure and architecture. But instead of choosing sides, the old or the new, it builds on the contradiction, and the drawing proposes an organic approach. This approach uses building technology to achieve the continuously adaptive growth of the tower based on the exciting heritage. Life in the future starts with cultural heritage. However, it also poses the question as to whether it is correct to build upon tradition by imitating? Does that create the best solution for our future society and physical aspects?

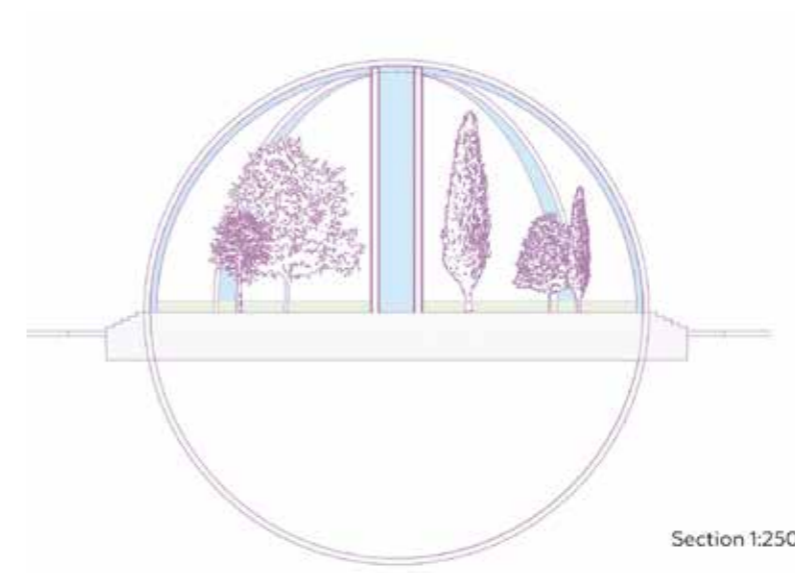
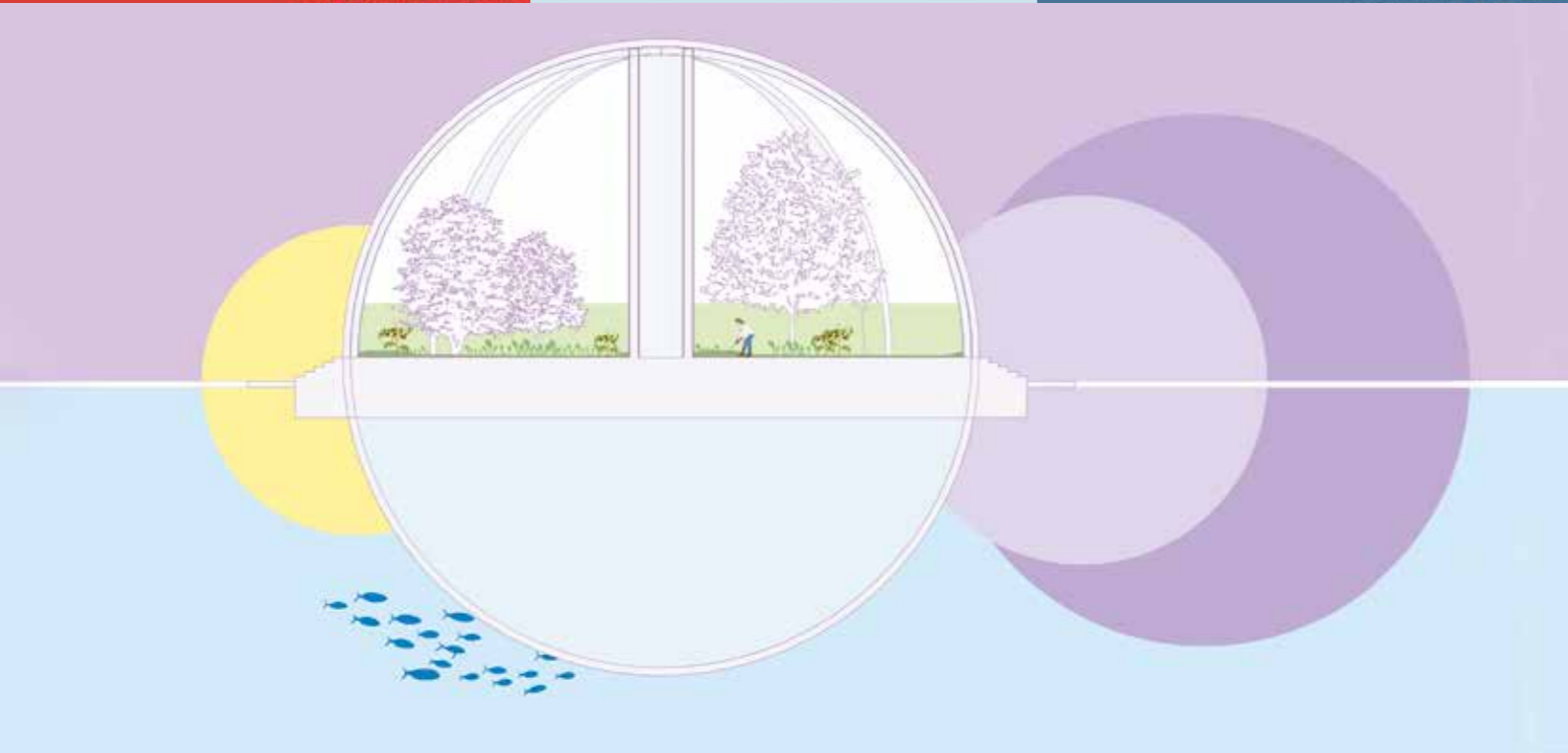

Section 1:250

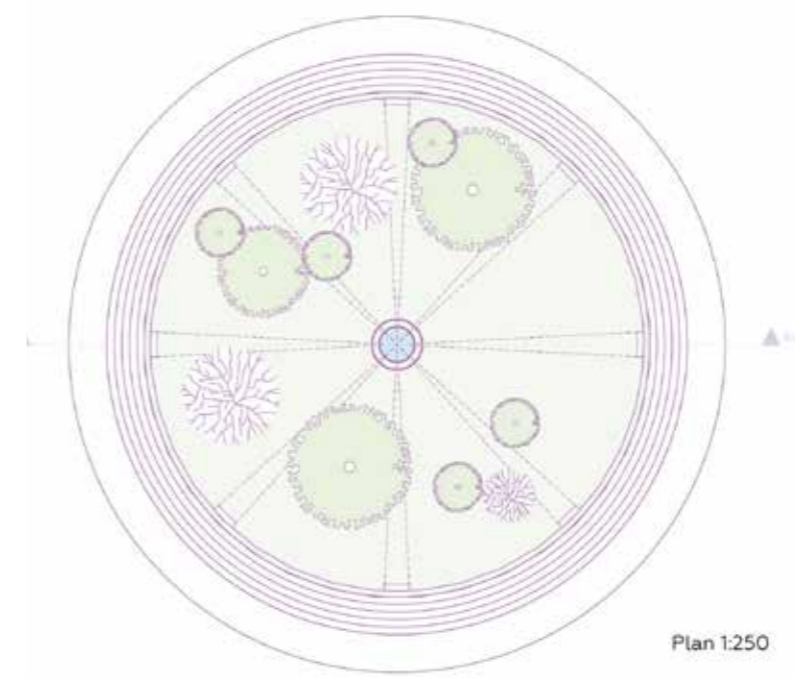

Plan 1:250

HOW DEEP IS YOUR GREEN
 FAIRYTALE OF THE FUTURE
 FLOATING CITY

Yuliia Surova
 DIA Master Architecture Thesis SS 2019
 Supervisors: Prof. Peter Ruge, Ivan Kucina

»Once upon a time, a group of researchers decided to conduct an experiment. They wanted to experiment with their lives, with the idea of climate change, with their lifestyle. They set out to change their everyday lives for the better and to seek changes in the whole world.« This marked the beginning of the fairy-tale of the future floating city.

Global warming is real. We need to admit this. Glaciers are melting, sea levels are rising and average temperatures all over the world are getting higher. Already, the question is not how to stop it, but how to adapt to it and preserve those parts that still survive. This will be a big task for architects – to create a new typology of settlements, new units. Each climate zone will need to be update. Floating cities can provide an answer to these challenges due to the energy consumption, mobility, flexibility and structural system of spheres. Sustainable impacts of the future floating city are materiality, energy, structure of the spheres, communal gardens. With an idea to create the city from all bio-materials, it could be built in 5 to 10 years from now. The project itself is semi-utopian in nature, but closer to a utopian future. Nowadays, new testing materials are appearing all the time.

Circles on the water

3 residential spaces are creating a unit for the stable perform

3 units creating another unit with a public space

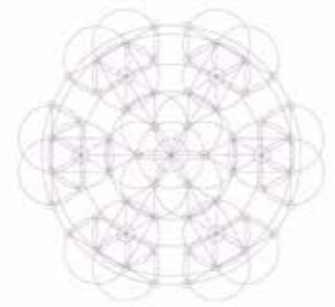

units created from residential and public spaces are producing districts of the city

Hexagonal shape in units

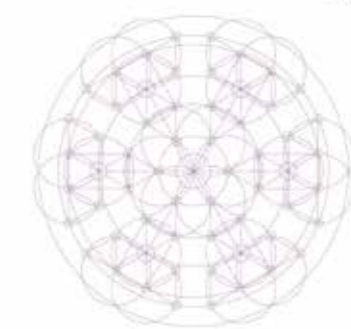
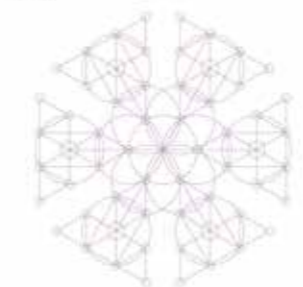
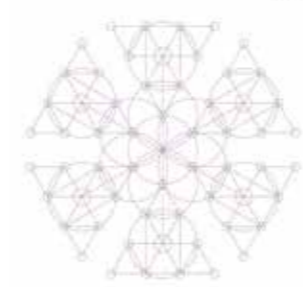

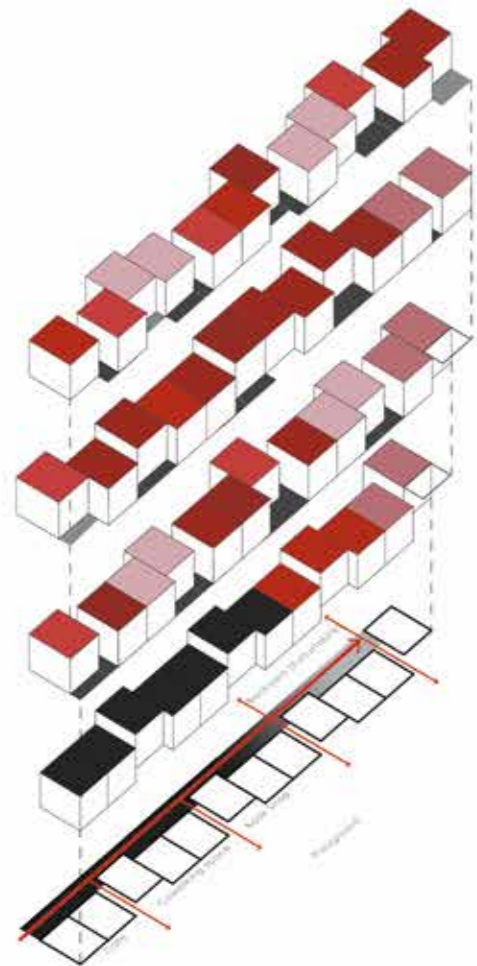

- Social housing 31%
- Artists 13%
- Couples 13%
- Students 13%
- Larger Family 16%
- Cafe 4%
- Co-working 6%
- Book Shop 4%
- Communal Terrace

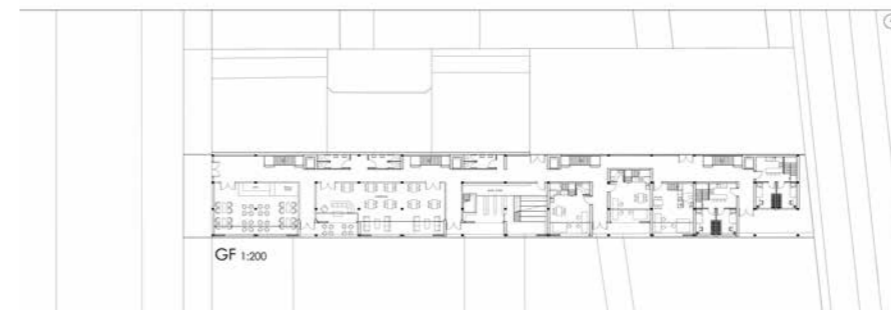
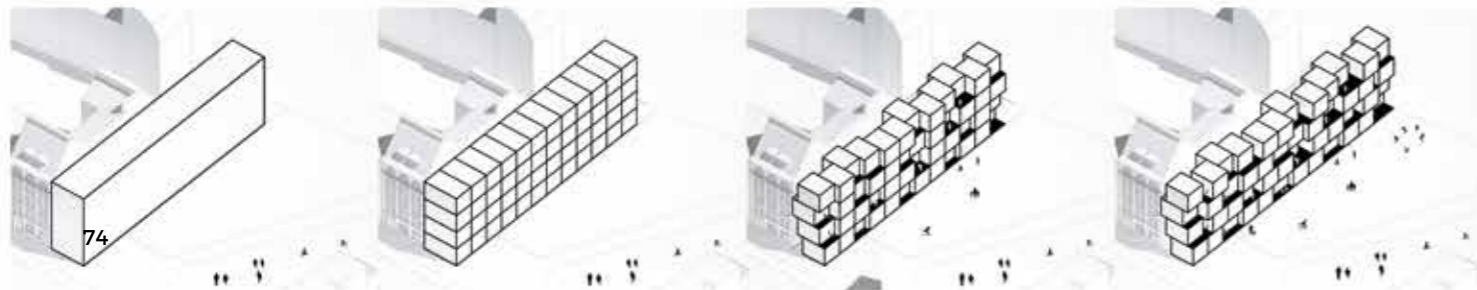
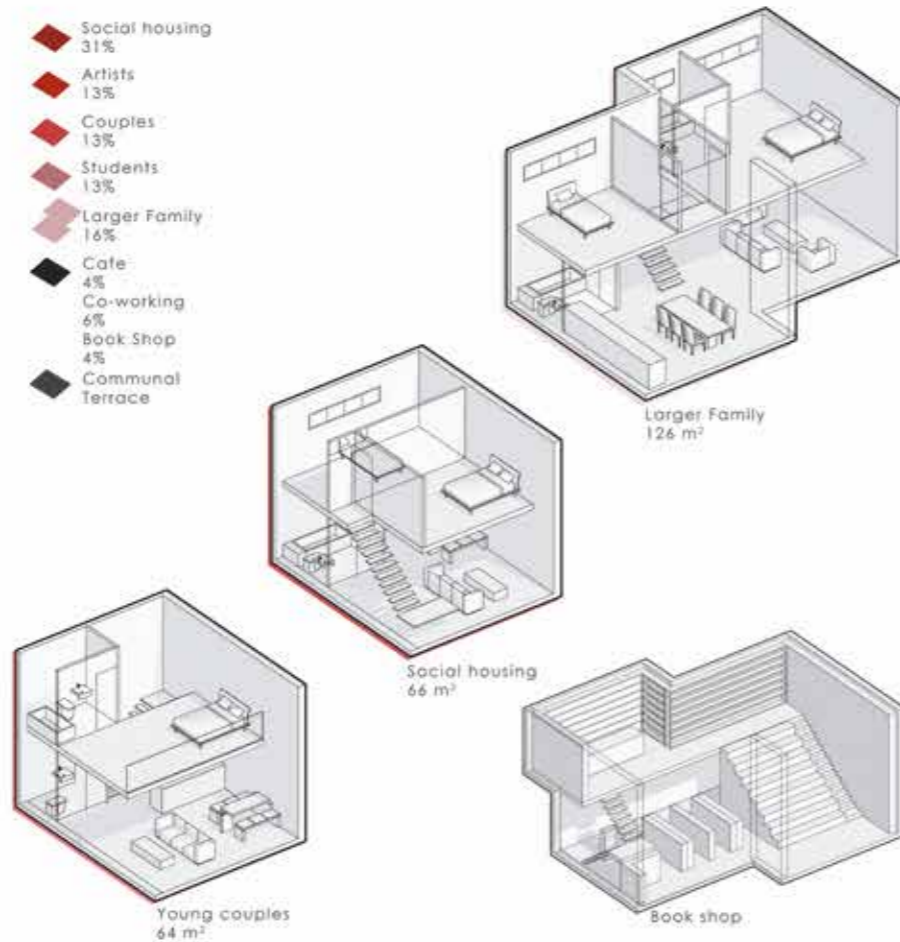

QUALITY SPACE
THE BRICK

Nora Chan
DIA Master Architecture WS 2018/19
Supervisor: Peter Apel

The design features small double-height modules that combine to form a large building. The layout of these units is flexible to allow a wide range of use for different population groups. The modules can be shifted to the left and to the right, backwards and forwards to form communal corridors and terraces that face the public space with visual interaction. Circulation on the ground floor is connected to the playground and the backyard of the Kulturfabrik to bring the exterior to life. The use of the primary material of the street, the brick, the identity of place is kept.





1



2



1 Studio Unit
Floor Area: 45 qm
Total Volume: 204 cbm

2 Duplex Unit
Floor Area: 67 qm
Total Volume: 320 cbm

3 Triplex Unit
Floor Area: 105 qm
Total Volume: 448 cbm

4 Family Unit
Floor Area: 155 qm
Total Volume: 768 cbm

3



4

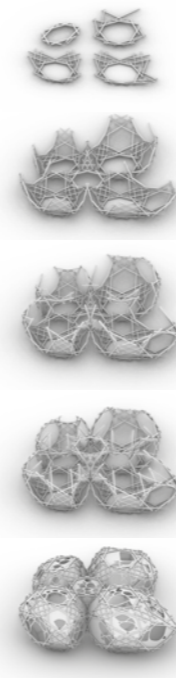

HOUSE CUSTOMIZER
KUALA LUMPUR, MALAYSIA

Mohamad Shazwan Mazlan
DIA Master Architecture Thesis SS 2019
Supervisors: Sina Mostafavi, Yu-Chou Chiang

Metabolism serves as a reference for this project. The concept of metabolism, ideas of nuclear physics, and biological growth was linked with Buddhist concepts of regeneration. Although metabolism rejected visual references from the past, it embraced concepts of prefabrication. This concept of thinking is implemented in this housing proposal based on the housing unit that can expand and shrink according to user preferences. Besides, this system is based on the Malaysian vernacular

building system, in which the resident can expand or remove part of the housing space if necessary. The reciprocal system is introduced to the project as a structural system for the building. By developing the system based on a reciprocal wood structure, the design not only suggests the construction but also provides opportunities for integrating functions in the exterior facade and the interior spaces. In addition to the building construction, the main material used for the building is the wood that is locally available in Malaysia. The implementation of advanced methods of computational design allows the users to customize their space or unit based on their needs or the intended function of the space. The form of the unit or space itself is identified with the help of parametric modelling using physics calculation programs.

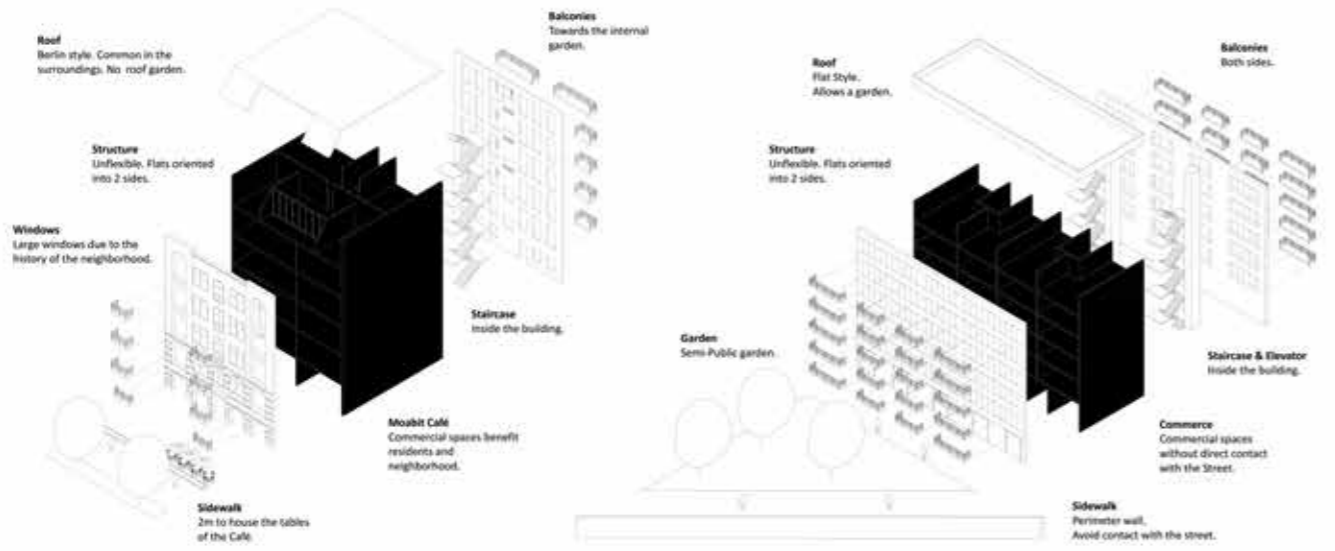
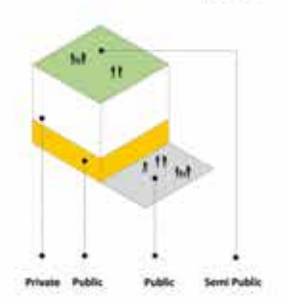
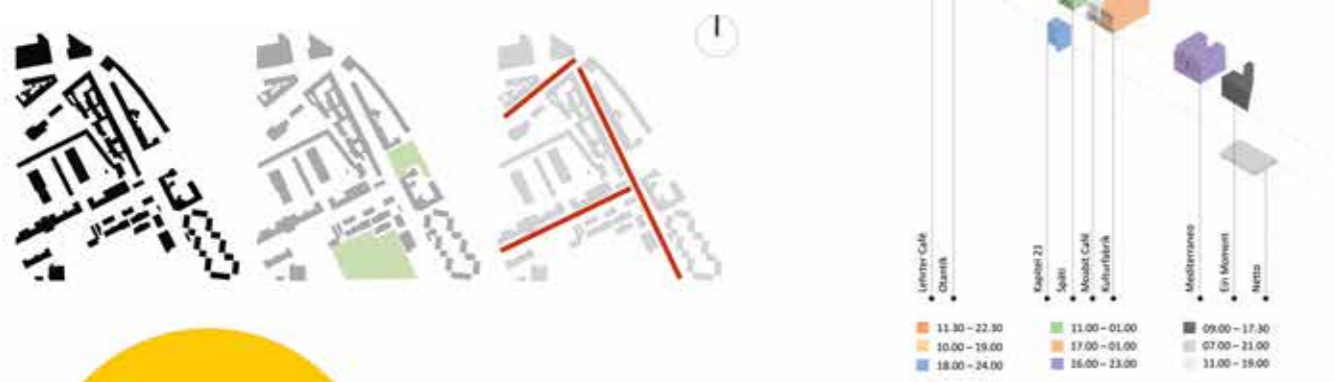

QUALITY SPACE
PATCHWORK

Eva Abuerto Flores
DIA Master Architecture Studio WS 2018/19
Supervisor: Peter Apel

Based on a site analysis, the area of Lehrter Straße can be regarded as a part of Berlin where the building typologies are representative of different social population groups. Similar to an urban patchwork, the buildings with the surrounding properties appear as disconnected islands. By offering many different apartment types as well as a common roof garden with green houses, the design brings the different inhabitants together and intensifies the social exchange. Large balconies expose the activities of the inhabitants to create visual and social connections to the playground in front.

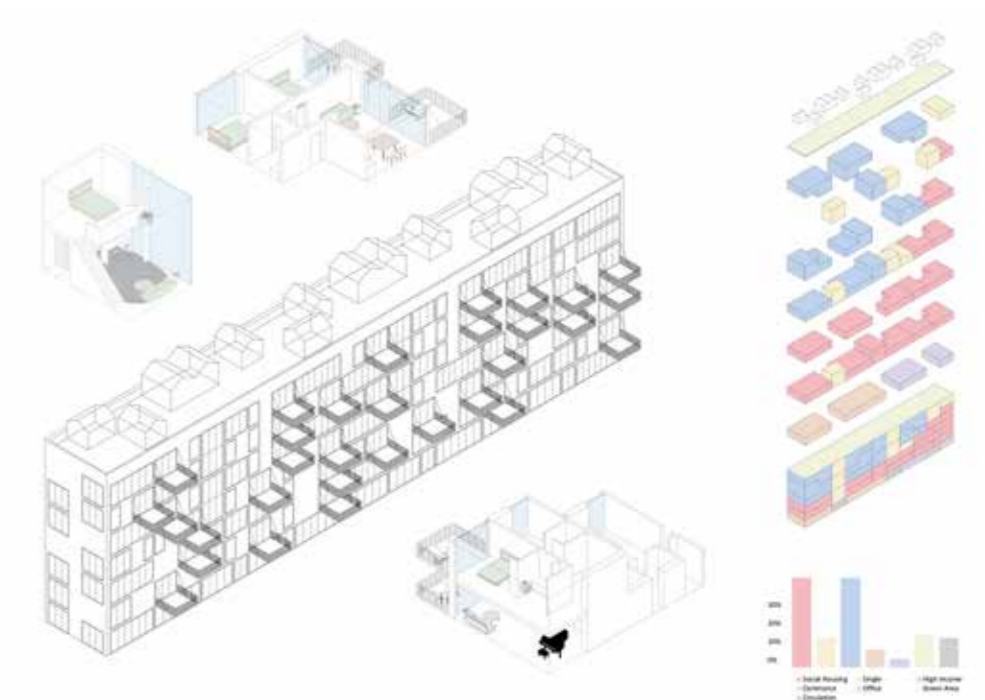

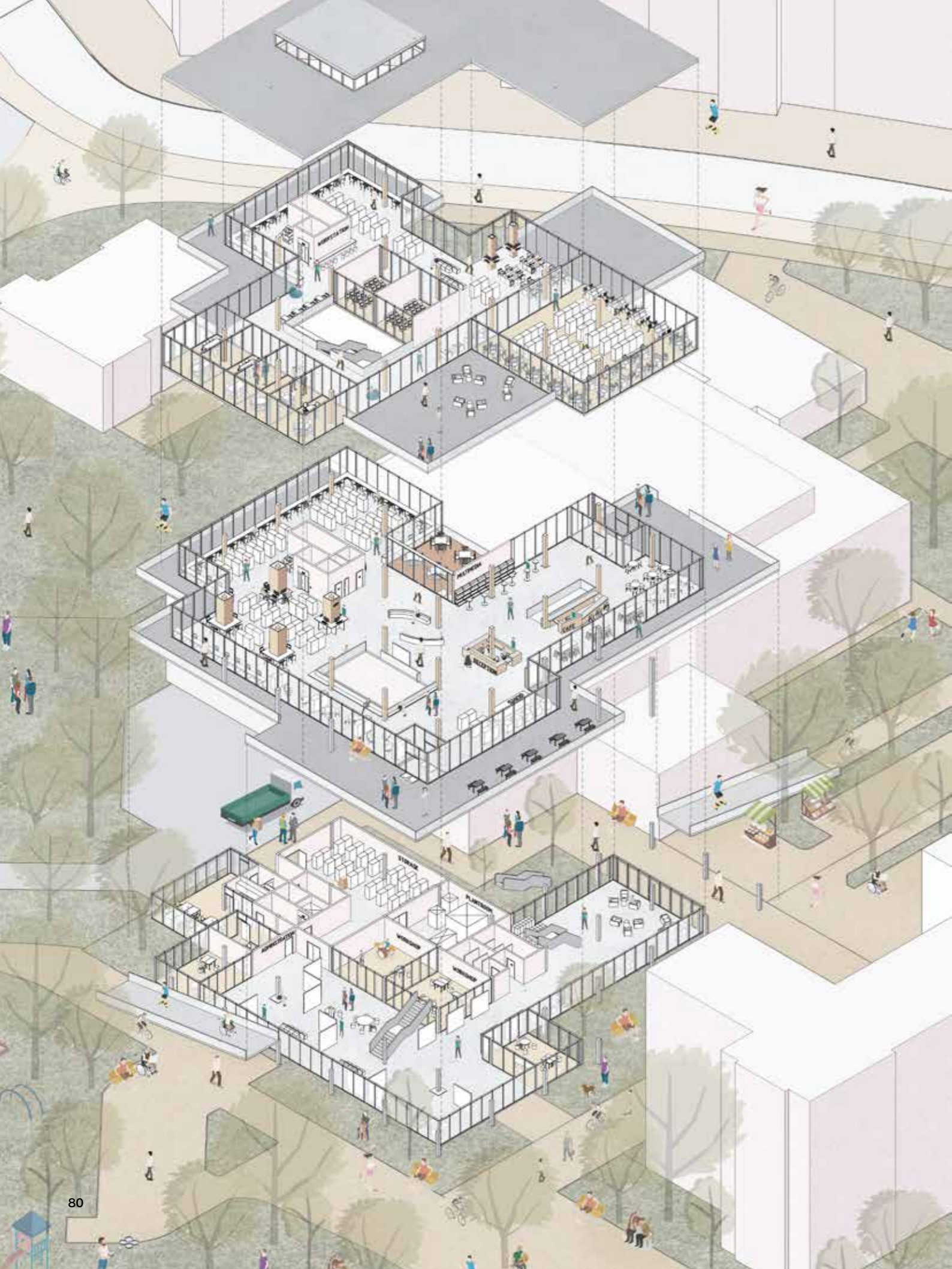

SITE AND SITUATION
OFF-GRID LEARNING CENTRE

Teck Wei Cheah
DIA Master Architecture Studio SS 2019
Supervisor: Peter Apel

The site is located in Fasanenplatz, Berlin, a park comprising a university, theatre and kindergarten that ensures that visitors to the park are not only locals, but also students from the university and visitors who come for cultural and educational purposes. However, the huge footprint of a parking deck at the heart of the park that fills the space between the university and the theatre created a dead end situation and broke the spatial connection of the park. The idea is to insert a learning centre into the park to reunite and revitalize the quality of spaces in the park. The unnecessary footprint of the parking deck will be removed to create a path that reconnects the park, while maintaining the useful qualities of the parking deck. Multiple levels will be added on top of the parking deck to create a terraced form that is not overbearing but inviting. The building's form is defined by the surrounding topology, which follows a kind of "grid" or pattern. The grid is then used as a basis for the design and is then broken at certain points according to the context and programme requirement, hence the "Off-Grid".

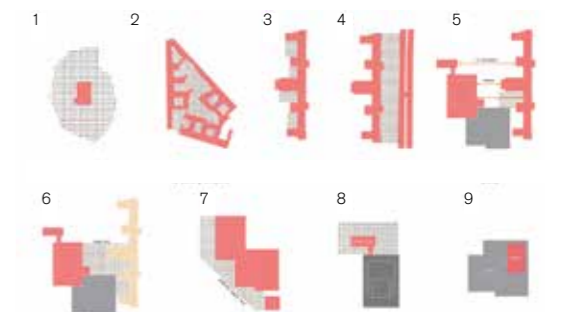

- 1 Island situation
- 2 Courtyard typology
- 3 Enclosure form
- 4 Road and pathway
- 5 Dead end situation
- 6 Protection and surprise
- 7 Extruded form
- 8 Highlights on top

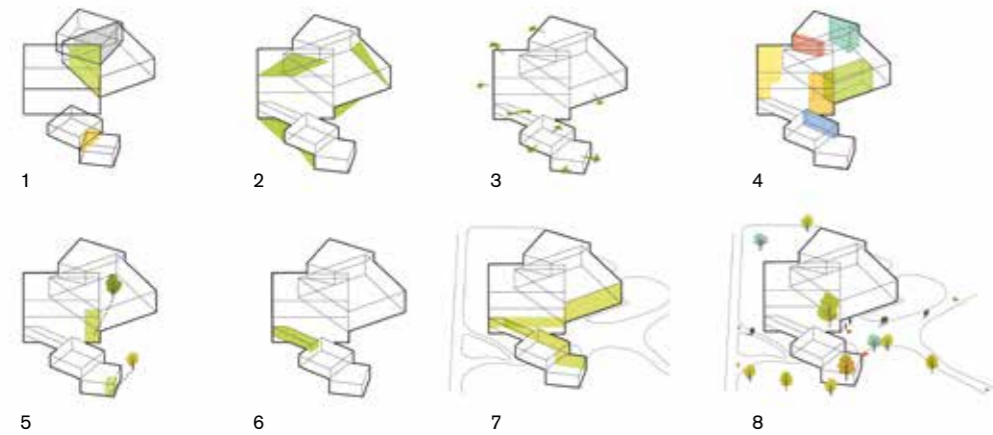

- 1 Intersection
- 2 In-between spaces
- 3 Areas of transparency
- 4 Interior voids
- 5 Exterior voids
- 6 Bridge connection
- 7 Arc of communication
- 8 Paths and entrances

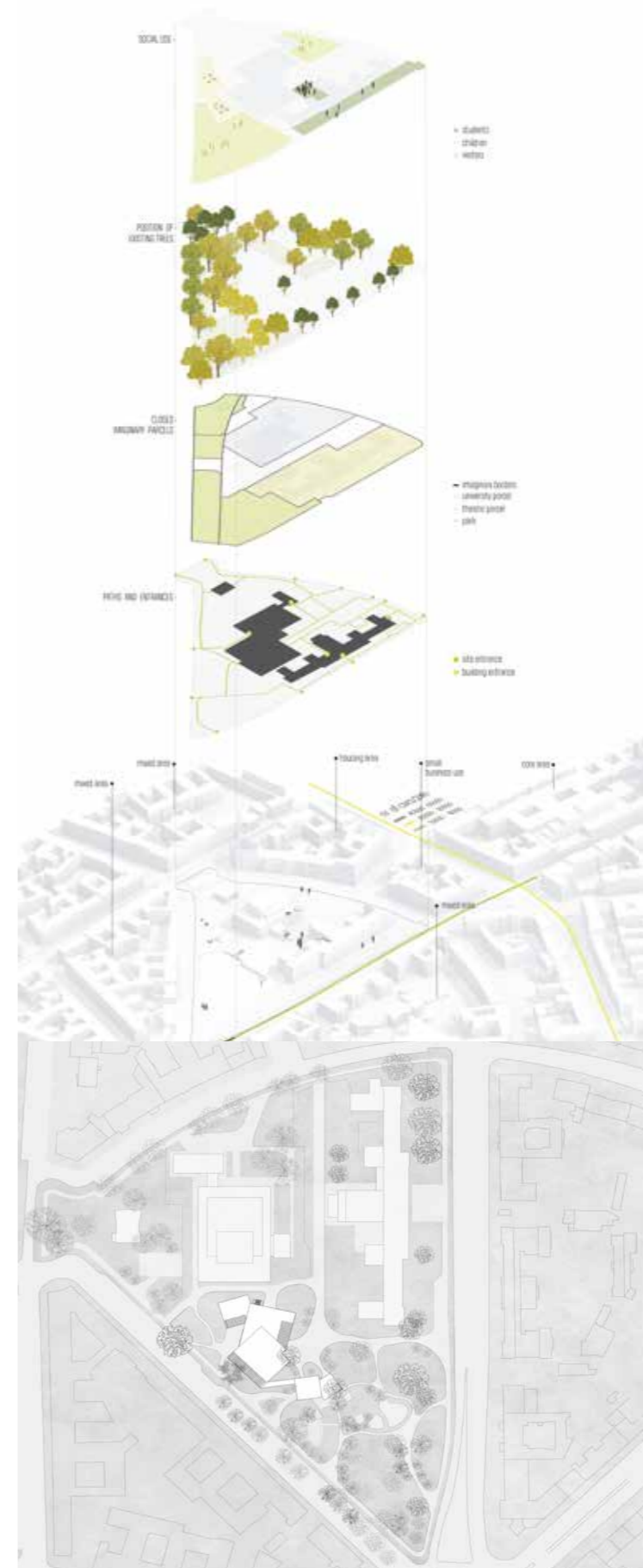

SITE AND SITUATION

W-HOLE

Gjiltine Isufi

DIA Master Architecture Studio SS 2019

Supervisor: Peter Apel

Located in a park in Berlin city centre, the learning centre is surrounded by astonishing trees and several cultural buildings on the site. Whereas an existing parking deck, a relic of the 1960s, was blocking the communication within the site, the design of a new building enables different users to make use of the park. The learning centre offers a wide range of programs that include a public and an academic library as well as a café, exhibition areas and group rooms to bring people together. The architectural layout of individual volumes whose positioning respects the locations of the existing trees also aims to divide the programs spatially. The intersections of the cubes allow fluid transitions between different situations for reading and learning. Made of 'holes and wholes', the design tries to evoke distinctive spatial experiences.





ARTS AND ARCHITECTURE
SKULPTURENPARK WALDFRIEDEN

Liew Chung Hooi
 DIA Master Architecture Studio SS 2018
 Supervisor: Eric Helter

In appreciation of the historical estate with its former structures and ubiquitous presence, British artist Tony Cragg set up a permanent site for the presentation of works outdoors in 2006. The concept behind my design was to create a building that blends invisibly into

the landscape incorporating an underground Experience Exhibition Gallery – described as a “Blue Box”. This is set out seven metres underground and is enclosed by a glass ceiling. From the ground floor, visitors can look down upon a deep cavern. In this way, boundaries between the inside and outside are blurred. Clearly, the difference between the spatial standpoints is indicative of the perception of architecture and offers a third dimension as viewpoint. In this spatial perception, tension is built up regarding the depth of this space – something which becomes tangible through the sculptures distributed throughout.

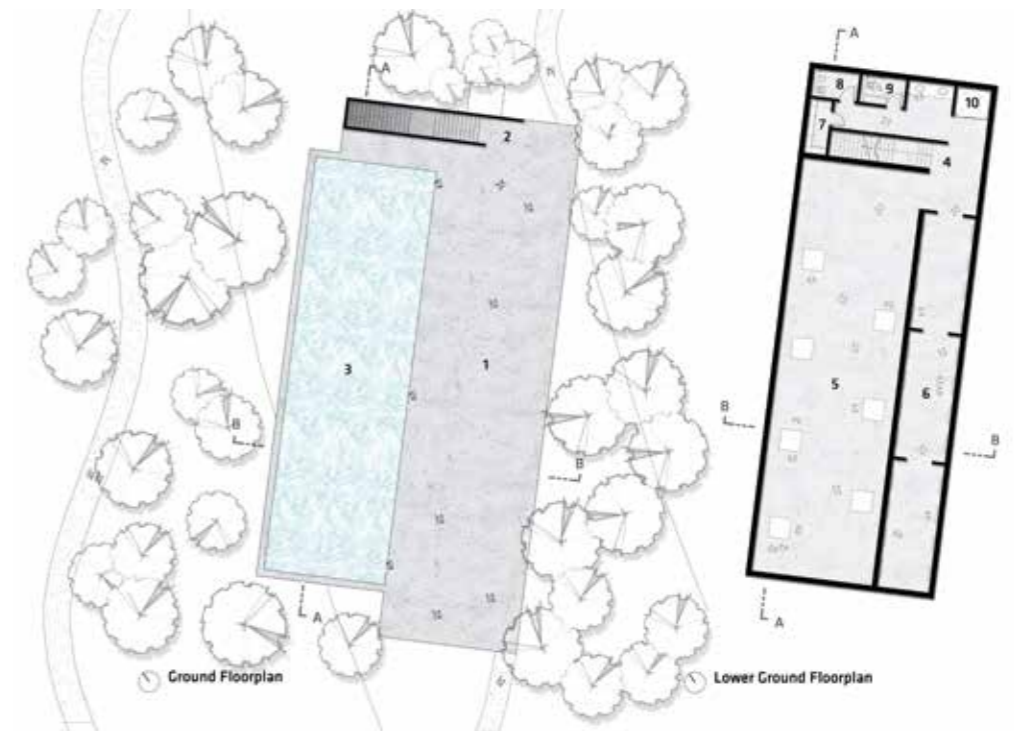

- 1 Gathering space
- 2 Entrance to underground
- 3 Water glass deck
- 4 Exit to sculpture park
- 5 Main exhibition
- 6 Art Frame exhibition
- 7 Storage
- 8 Toilet Men
- 9 Toilet Women
- 10 Lift
- 11 Water feature

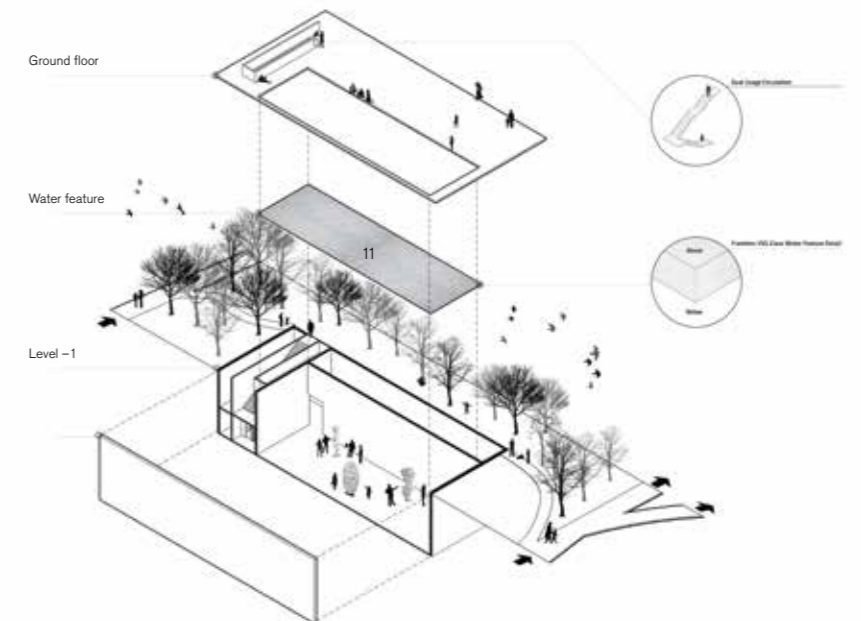

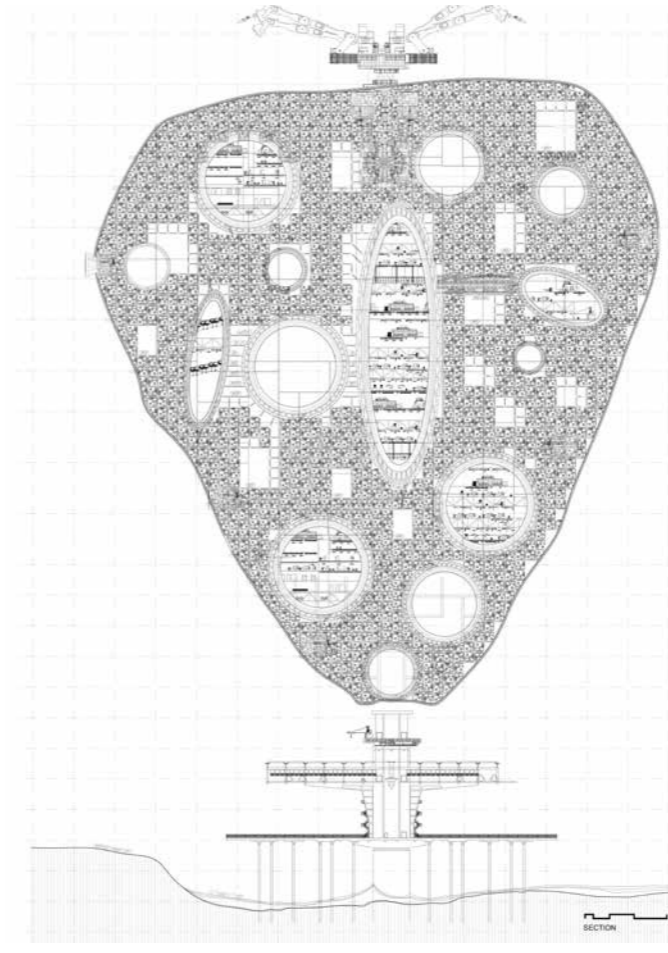

ROAD OF DREAMS
2080 TOMORROW

Chin Yan Jun
DIA Master Architecture Thesis SS 2018
Supervisor: Prof. Peter Ruge

Theories of sustainability attempt to evaluate and integrate social responses to architectural, environmental and cultural challenges. The concept of sustainability raises a basic question, "Can human activity successfully maintain itself without exhausting the resources on which it depends?" Milestones reached in the understanding of sustainability include: "Limit of Growth" in 1972; "Our common Future" in 1987; "Bottom Up versus Top Down" as economic models; "Biodiversity" as an ecological model and "Autonomous Self-Sufficiency" as a political model. Today, best practice begins with grassroots approaches to sustainable design methods that explore and analyse single aspects of a program. These economical, ecological and human-centric concepts are evaluated and synthesized, resulting in a modern and future-orientated spirit of design.

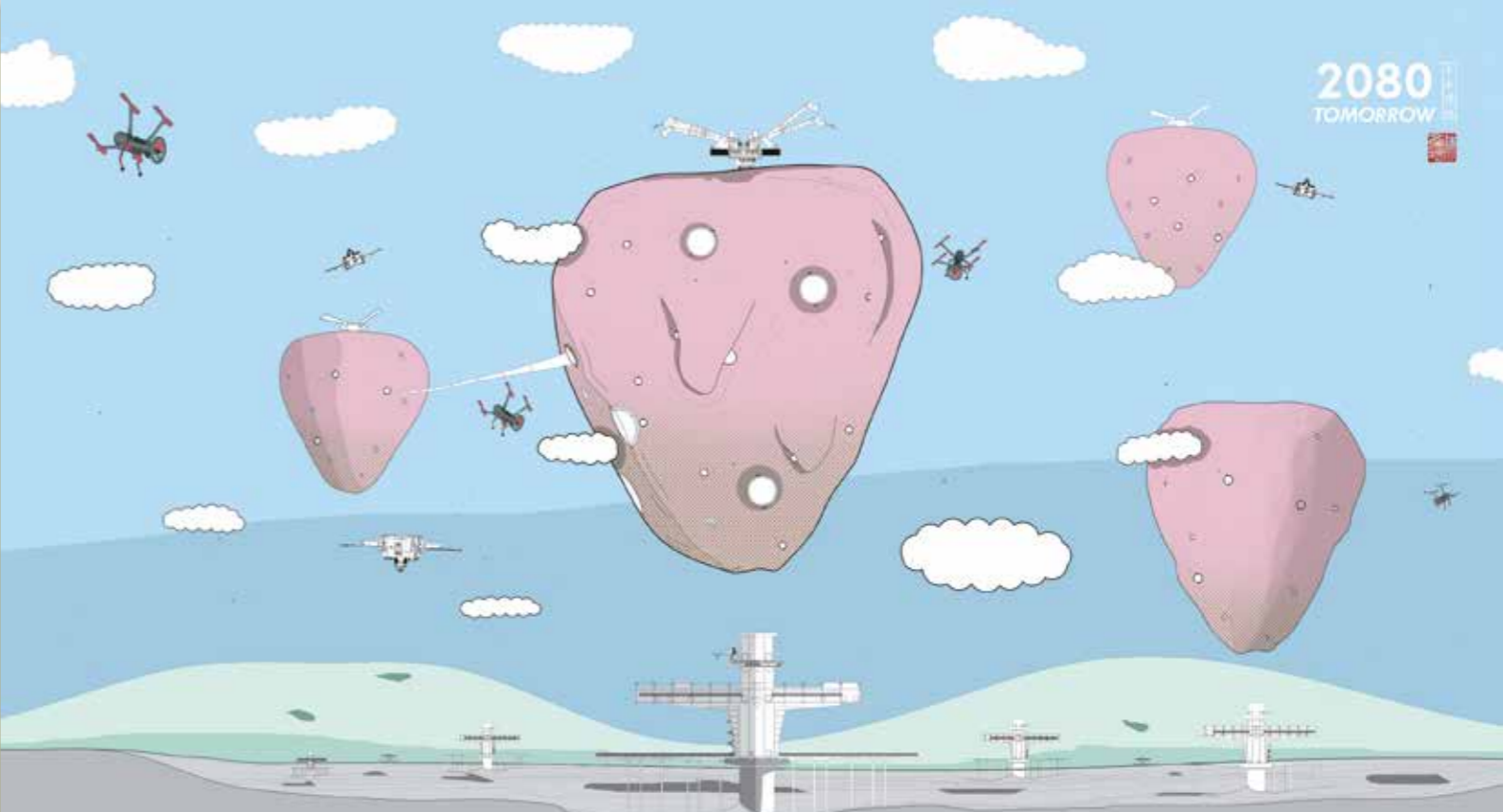
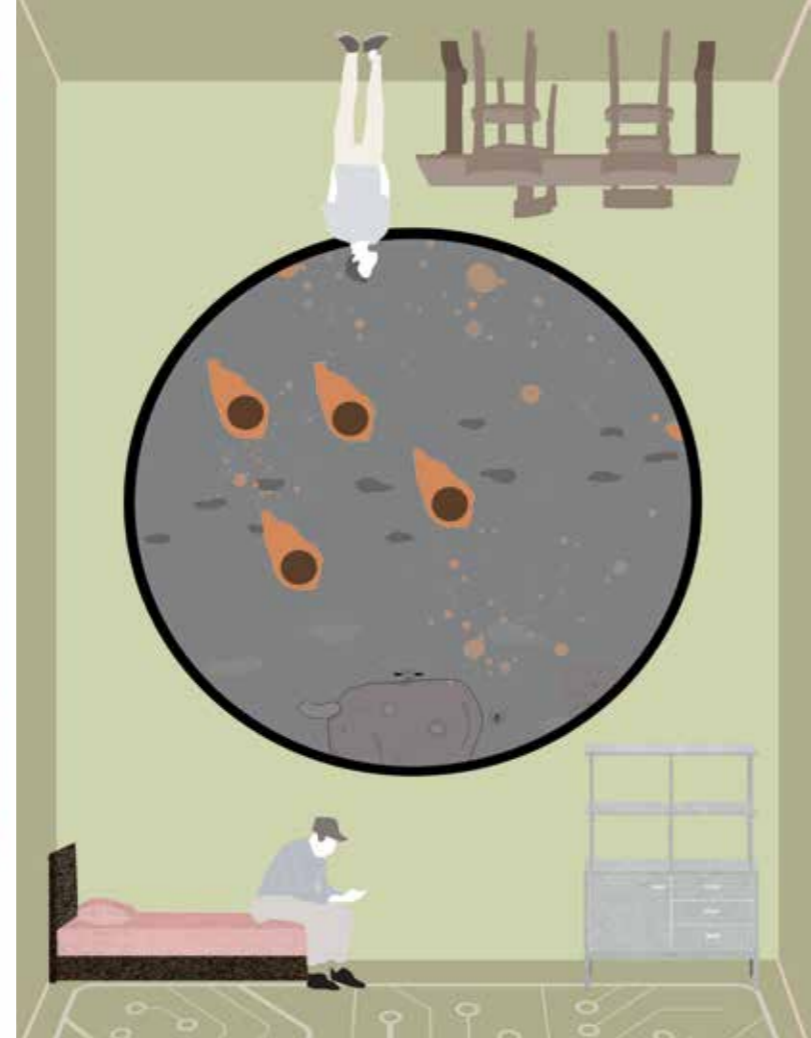

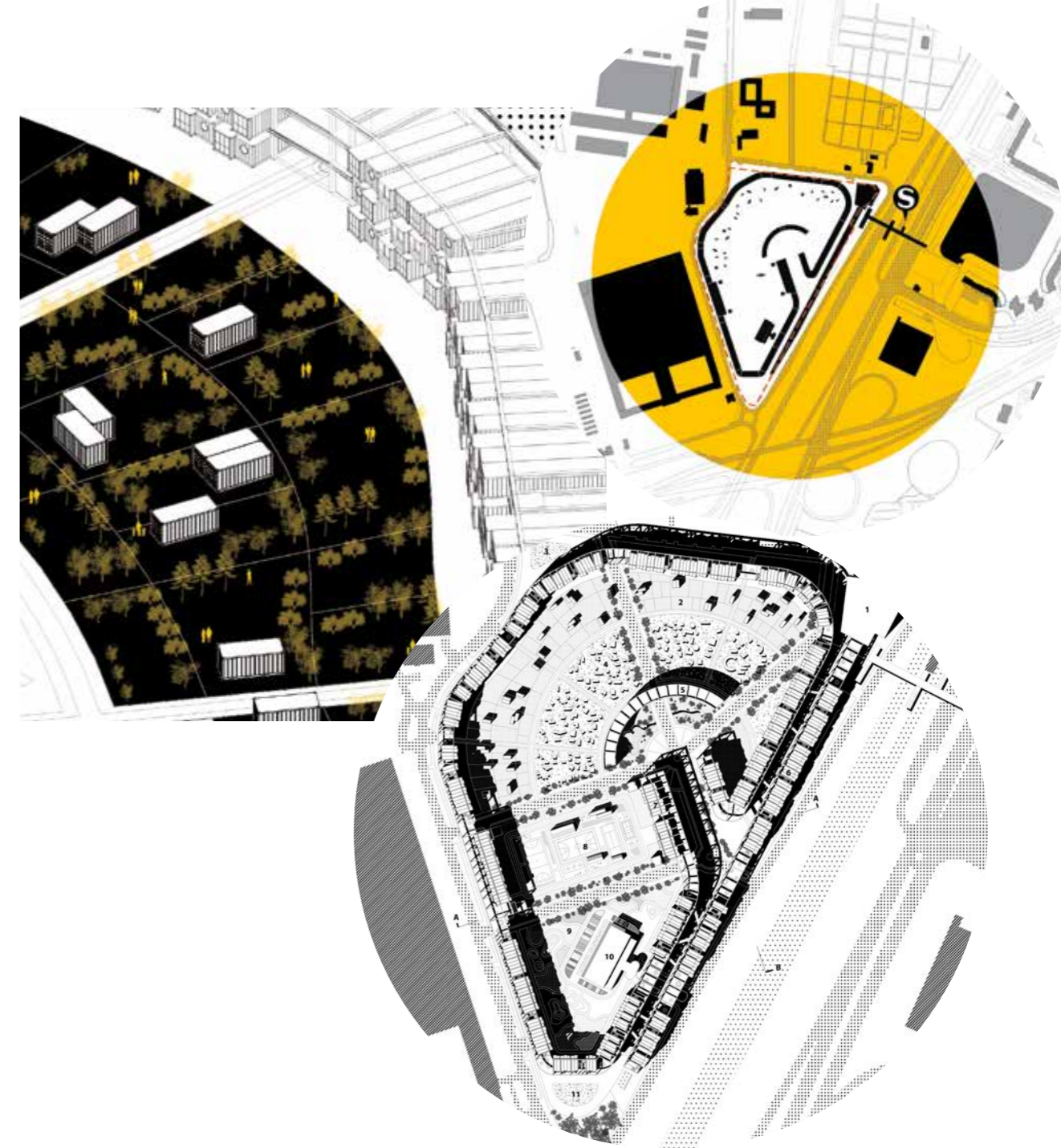

THE UNCONTAINED METROPOLIS
THE PRODUCTIVE AND CREATIVE CITY

Soh You Shing
 DIA Master Architecture Thesis SS 2019
 Supervisors: Christoph Kohl, Ivan Kucina

The project is located in Marzahn, on the east side of Berlin. Under the theme “The Creative and Productive City”, the aim of the planning measures was to develop a lively and appealing district that fully considers and incorporates the existing listed industrial monuments. When do people feel most comfortable? People tend to feel more serene when they have access to natural surroundings or when they experience open fields and agriculture. As we all know, every town has a border with the village, but a good city will only be created when it includes dense interaction between people and work with different lifestyles. The research of this project mainly focuses on landscape programming which allows the people to create and afford a new identity in this uncontained metropolis.



PRODUCTION SPACES
VERSUS URBAN CONTEXT

Rostyslav Skyba
 DIA Master Architecture Thesis SS 2019
 Supervisors: Antje Buchholz,
 Jürgen Patzak-Poor, Roger Bundschuh

Research
 Starting with the guitar production exploration, my point of interest became the relation of spatial layers that form a chain from the workbench to the urban context. I explored the spatial qualities and potential of production typologies that are tightly woven into the city texture.

Design
 The selected site lies on the boundary between the industrial island and the city. Due to this proximity, the industrial zone is undergoing a process of transformation. The defined site has the potential to become a link between two areas and will function as a passage. My focus is on its entrance group from the city side, which is considered as the main transition. Its presence elevates the significance of the area behind.

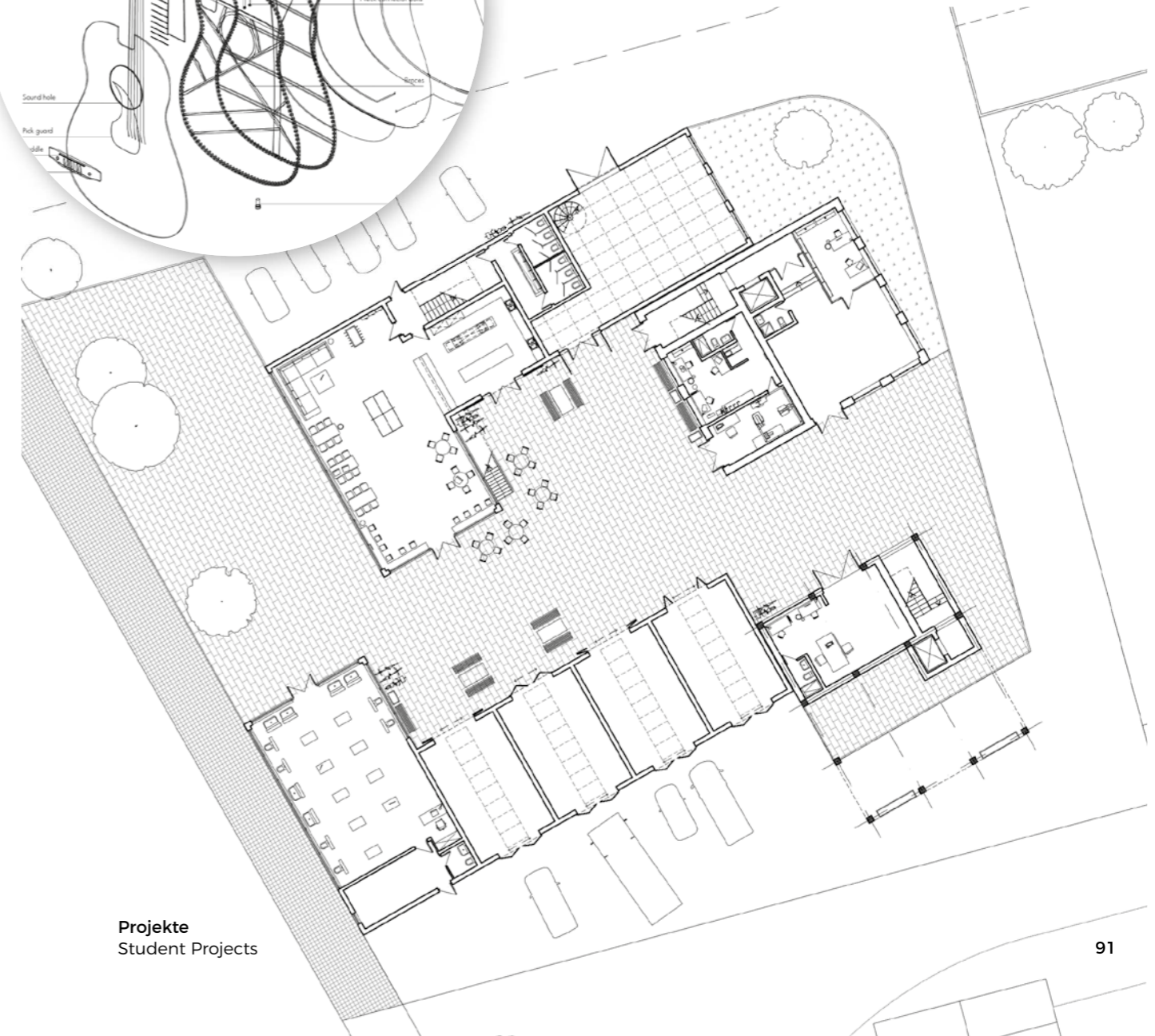
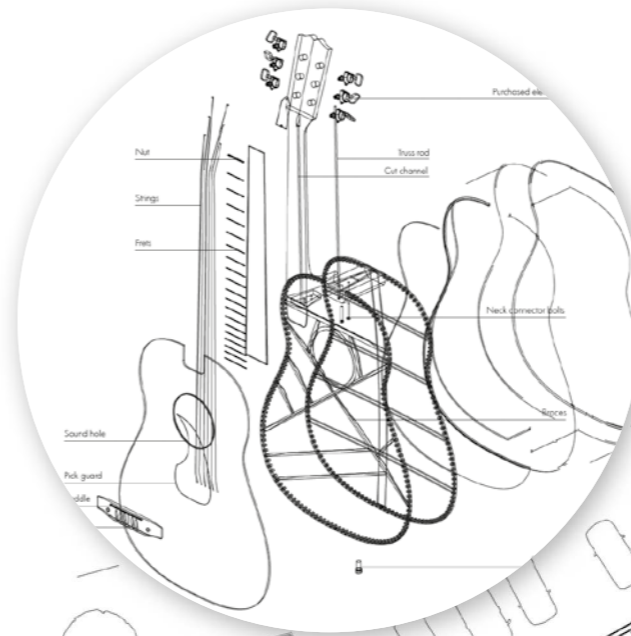

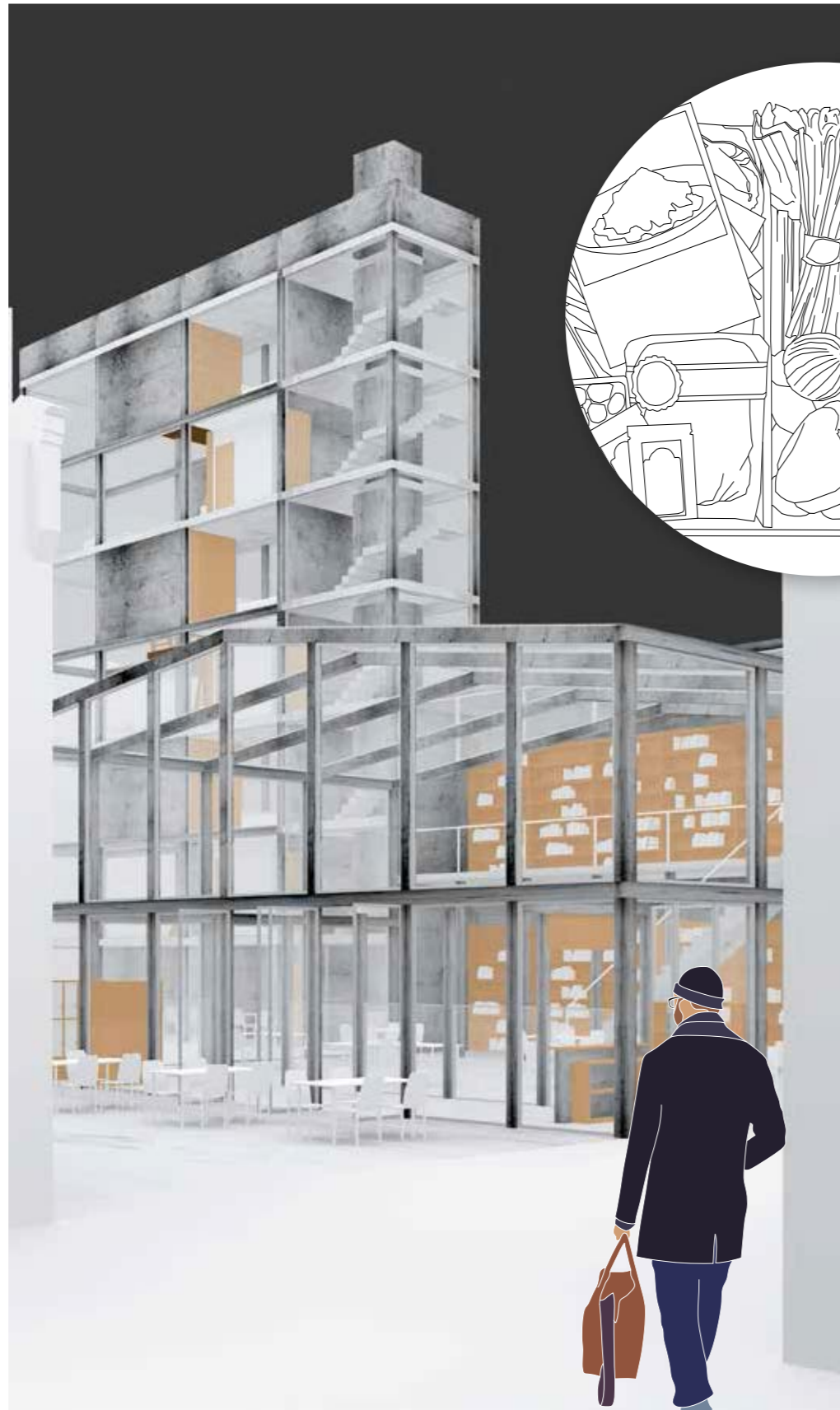

Worker leaving from office, passing through the new courtyard.



HIDDEN FOOD NETWORK IN THE CITY

*HOW TO INTERFERE IN THE EXISTING
FOOD CHAIN AND IN THE EXISTING
URBAN FABRIC*

Paul Riant

DIA Master Architecture Thesis SS 2018

Supervisors: Antje Buchholz,
Jürgen Patzak-Poor, Roger Bundschuh

The research aims to study the food chain and the network of two contrary contemporary concepts: a disconnected food delivery company and a locally associated NGO, both of which work to improve the social community. Neukölln is features many courtyards that

refer to its industrial manufacturing past. Nowadays, the leftover spaces are used as junkyards, parking lots, passages. Regarding the diversity of the food facilities in the immediate surroundings, the project interferes with the existing food chain. It reclaims the surplus and unsold food, most of which is thrown away. The design proposes an alternative way of densifying areas by exploring the possible site and paying attention to the past in order to maintain consistency regarding the subsequent interventions. Leftover food – Leftover space. The project creates a dialog between the ornamental heritage facade and the eponymous volume in front of it. The different courtyards designed works as sequences for the users: a food workshop, a cooking school, an exhibition pavilion, a food resources centre, and a sleeping tower.

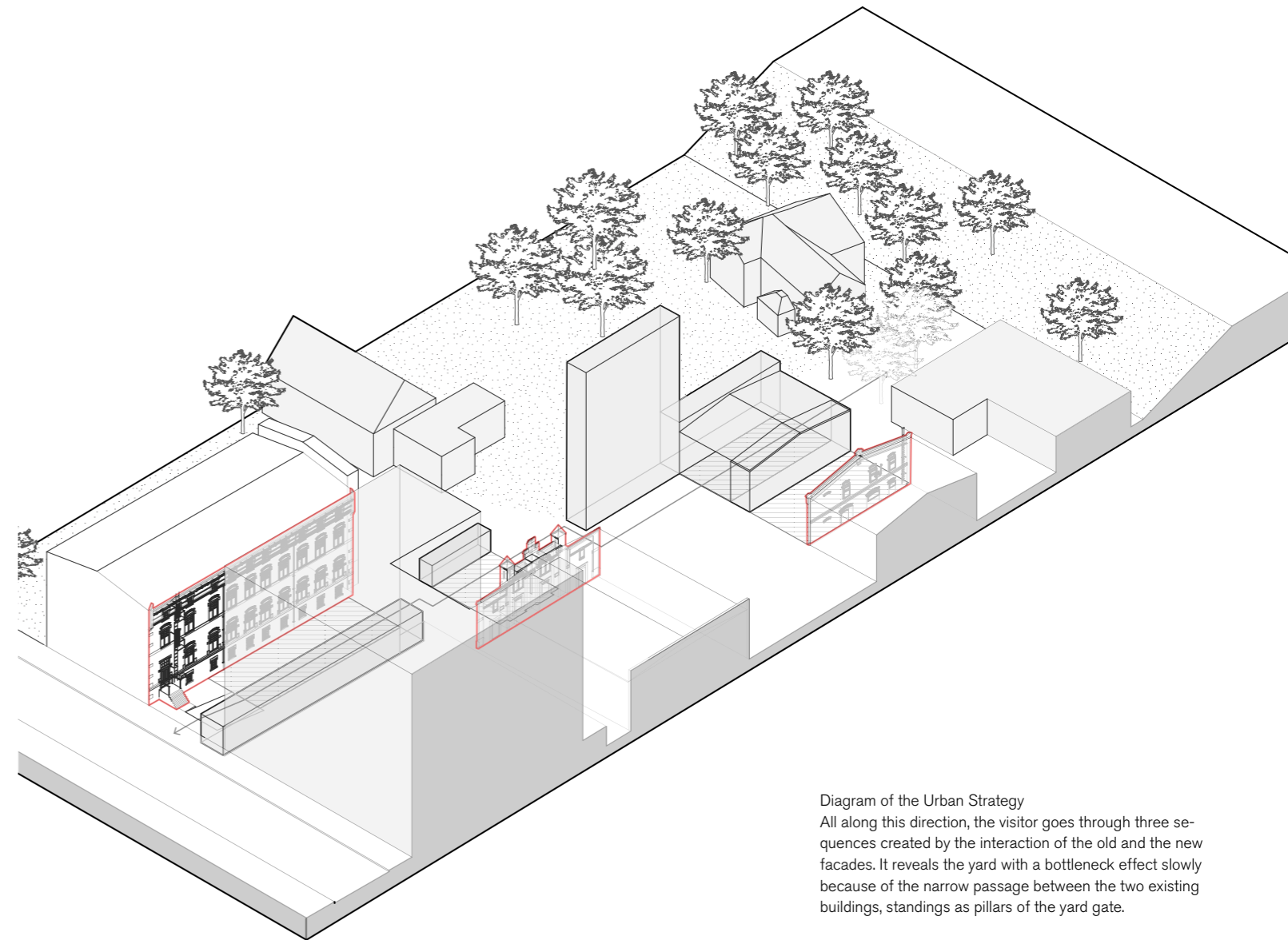
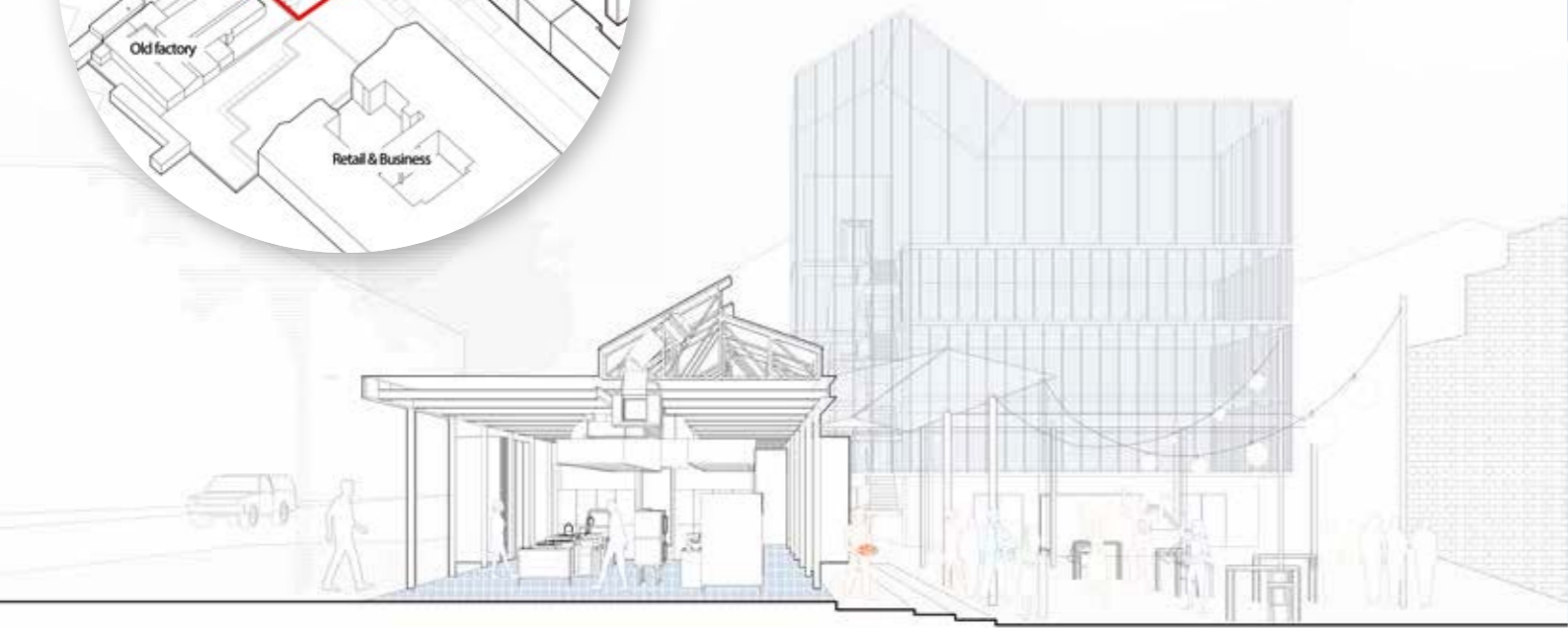

Diagram of the Urban Strategy

All along this direction, the visitor goes through three sequences created by the interaction of the old and the new facades. It reveals the yard with a bottleneck effect slowly because of the narrow passage between the two existing buildings, standings as pillars of the yard gate.



STREET(EAT)ING
PUBLIC KITCHEN

Valentyna Bondarenko
DIA Master Architecture Thesis SS 2019
Supervisors: Antje Buchholz, Jürgen Patzak-Poor,
Esteban Lamm

Support for communication

The public kitchen project attempts to become an uplifting event for inhabitants of Moabit by creating a platform for collective cooking and engaging with each other. The project proposal aims to support the social quality of the area and improve the street life. At the centre of the building is the kitchen, which houses a large cooking station where different chefs prepare meals and share the experience of cooking and eating with everyone. It is an inviting space that creates an event atmosphere and can be viewed from the street.

Local solution is support for heritage building

In Moabit, most of the public amenities such as shops and restaurants are situated along the main street of Turmstraße. This changes towards the river, which is traditionally dominated by industrial/commercial premises. Consequently, gastronomic premises are scarcer, resulting in fewer

social activities such as dining together and socializing. The project proposal aims to support the social quality of the area and improve the street life. The site in front of an historical factory will be enlivened by transforming the process of cooking into a public event, thus enriching the monotone atmosphere of the area.

Physical support structure has a dual nature

The architectural intervention is positioned opposite the factory to create an in-between courtyard that functions as an open social area. The project is modest in scale and relates in terms of height and transparency to the presence of the brick masonry heritage building. It is a lightweight structure that does not block the view towards the factory. It is close to the pavement for improved interaction with pedestrians. It is an inviting space that people can look into from the street. Large doors mediate between the inside and outside of spaces.



1. OG



2. OG



3. OG



4. OG



DG



Bild 1/2: Plaza im Sommer und Winter
Bild 3: Foyer

SEAB HEADQUARTER OFFICE BUILDING IN BOLZANO

Billy Novia Prima
DIA Master Architecture Studio SS 2018
Supervisor: Prof. Johannes Kalvelage

The project site is located in an industrial zone of Bolzano in Italy. The project site is in the corner plot with an existing office building and the Municipality of Bolzano adjacent to the site. This will be one of the biggest challenges of how to integrate the new building with the existing buildings. The design concept is driven by SEAB's company aim of providing a superior quality of life for the people in the city. The spaces are designed to improve the current

condition of the site and to address the problems of the SEAB's current office. The building is divided into 3 segments of public spaces on the ground floor; semi-public spaces on first to third floor and private offices are located on fourth and fifth floor. The ground floor is fully accessible by the public and is in fact designed to welcome the public to stay and enjoy the space. The plaza between the new head office and the Municipality of Bolzano serves as a buffer for the buildings, while also creating a pleasant enclosure that can adapt to the changing seasons. In summer, it can be a water plaza where the public can walk around a shallow water pool to cool down from the heat. In the winter, it can be transformed into an outdoor ice skating rink.





The project is located in the district of Bolzano-Adige, in Bolzano, the capital city of the province of South Tyrol in northern Italy. The district, as well as the city have experienced a process of change, from a place with a heavy industry background, to the development of new architectural purposes in the region. The construction of the Bolzano, Bolzano, and various settlements have transformed the area into a productive space with a mix of industrial, craft and commercial activities.

The objective is to design the new administrative headquarters for SEAB, next to an already existing company building. The area is quite challenging due to spatial restrictions, with the existing building on the south, the police station on the west side of the site, as well as a shopping mall across the street which intersects the already highly trafficked junction of its connecting axis. The connection between via Gallia Gallia and via Venezia lanes.

The program proposed consist of six main structures, client services, technical services, administrative, reception, parking and common space for employees and clients. The program is contained within two overlapping volumes, one on top of the other, both open in the center and oriented in order to create a public courtyard that opens to its main axis, via Gallia, in order to create fluidity and connection. The main objective of the project is to create a central point, a connective axis between the client and the company, in order to develop a stronger relationship with the city of Bolzano.

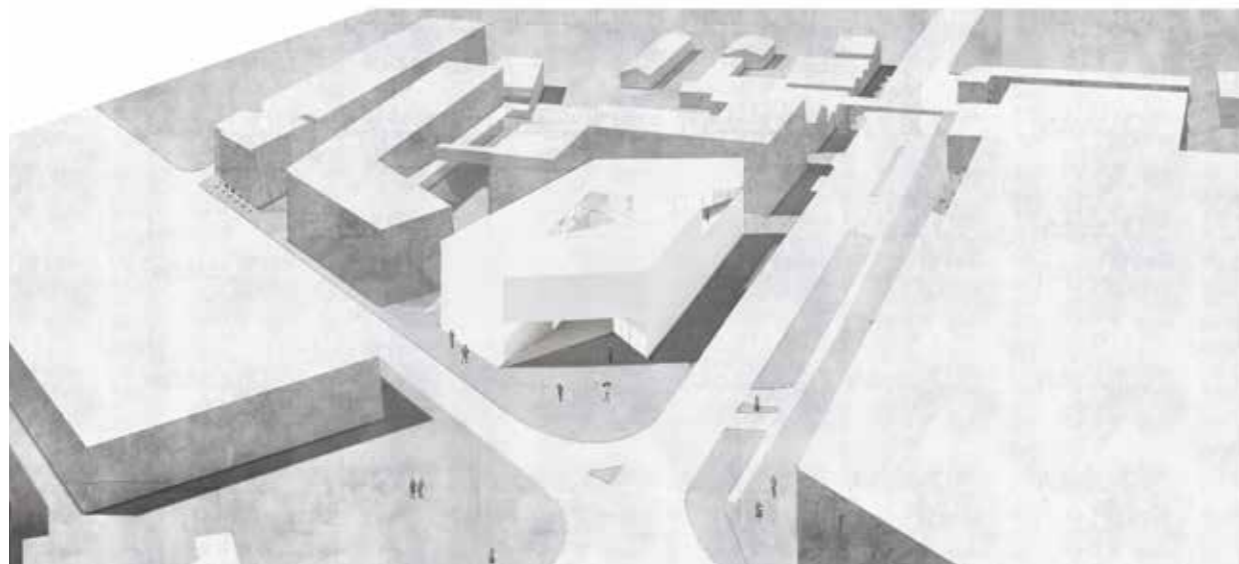

SEAB HEADQUARTER
BOLZANO, ITALY

Lizzette López Martínez
DIA Master Architecture Studio SS 2018
Supervisor: Prof. Johannes Kalvelage

SEAB is a municipal company located in Bolzano, Italy. It was set up in 1976, to ensure a coordinated management of public services, such as the potable water supply, removal of wastewater, distribution of natural gas, cleaning of roads and green areas, waste management, recycling centre, collection centres and

management of garages, parking lots and blue parking spaces. SEAB not only provides for the city, but also contributes to protecting the environment through strict environmental and safety standards in the workplace. The company also focuses on eco-friendly energy production, exclusively from renewable sources, generated in the hydroelectric power plants of South Tyrol. SEAB's work involves implementing, maintaining and monitoring the necessary infrastructures. "High-quality drinking water, a perfectly functioning gas network and sewage system, clean streets and a well-kept urban image are not only a city's calling card, but also indicators of a high quality of life." – SEAB

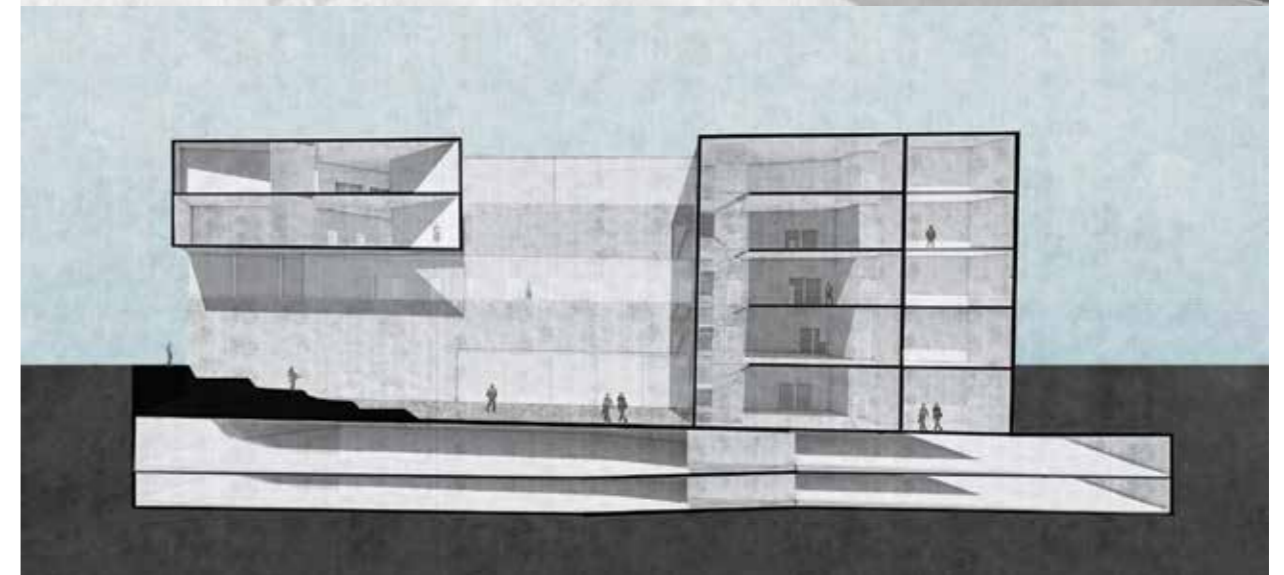



Bridge2future
CENTRAL AND REGIONAL LIBRARY,
BERLIN

Mohamed (Farid Aly) Sayed Ahmed
DIA Master Architecture Studio WS 2018/19
Supervisor: Prof. Ralf Niebergall

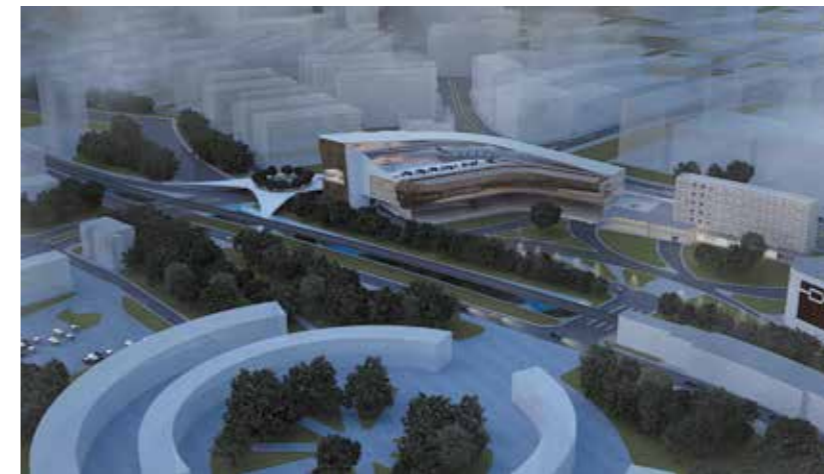

The City of Berlin wants to centralise its libraries and repositories that are currently spread across the city in one single point. It will be the biggest public library in Germany with a usable space of 37,400 m² in total. Despite the availability of all the world's knowledge, thoughts and literature on a little smartphone, libraries still play a key role in the cultural life of a city. The intention is to make this 21st century library a unique cultural hub that fulfils the information and communication needs of a mobile, multi-ethnic urban community and serves as a forum of "living democracy" and to foster the exchange of ideas among citizens.



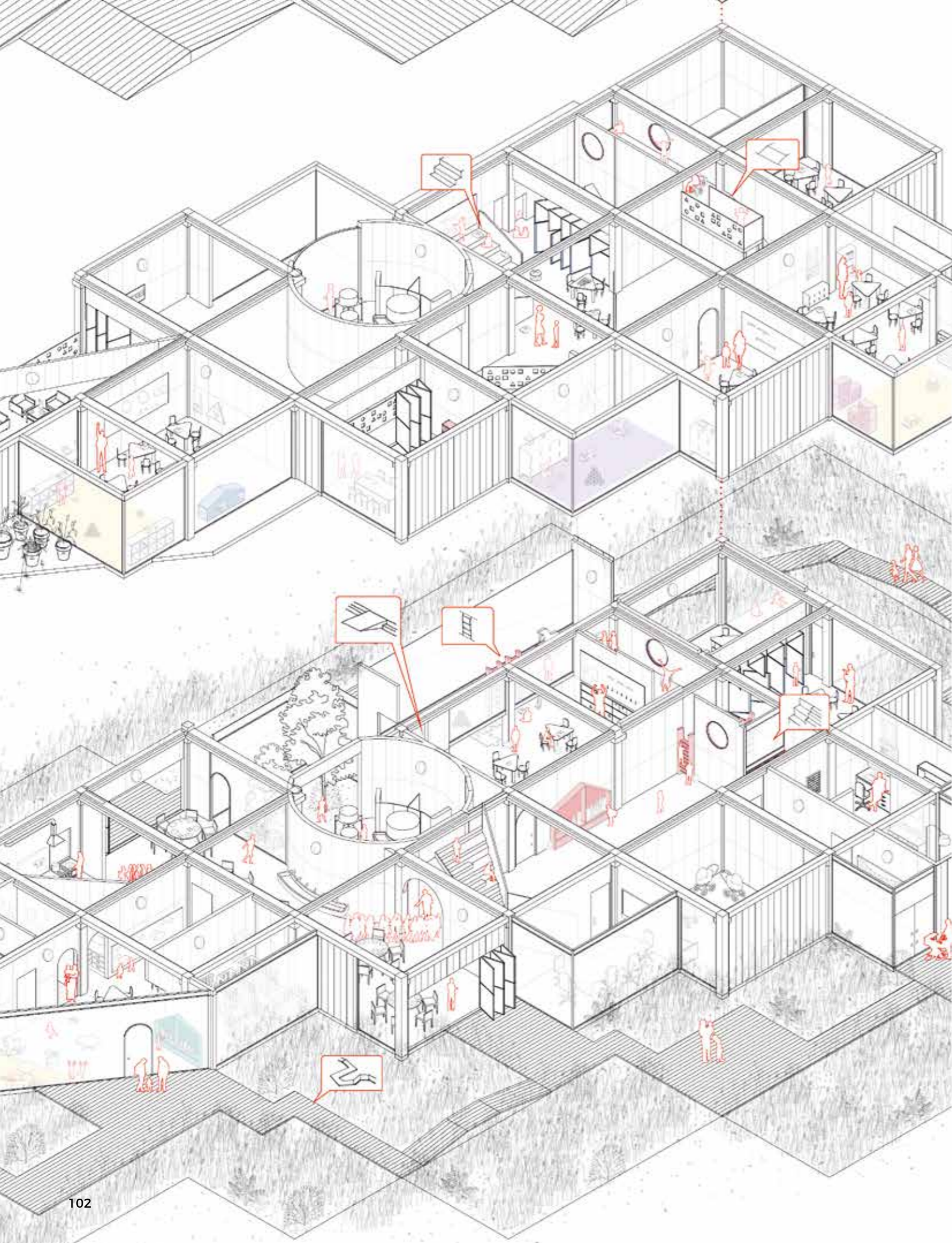

SPACE BLOCKS

HOW TO CREATE INTERNAL SPACES

Yan Mai Chun

DIA Master Architecture Studio SS 2019

Supervisor: Prof. Dr. Natascha Meuser

Learning is part of the journey of life. Kindergarten is one of the places that most of us started to learn and gain life experience outside our homes. We were given a design task to create a kindergarten in a peaceful neighbourhood in Erkner, Berlin. Three design parameters were discussed and integrated into the kindergarten design. The first consideration was the visual connection or passive contact that children have with each other, and the neighbours. The arrangement of corridors, the transition spaces and the children's circulation path were all crucial considerations when planning the space. For the task, the planning of space was affected by the shapes and forms that were chosen. Children are visual learners. One of the advantages of the design is that children will have a better understanding of 2D and 3D structures. A space cleaning activity was suggested in order to allow children to develop a sense of depth in relation to their living environment. Playscape elements were replaced with simple elements such as ladders, ramps, steps, etc, so as to contribute a new play experience for the children, within the building and outdoor spaces.

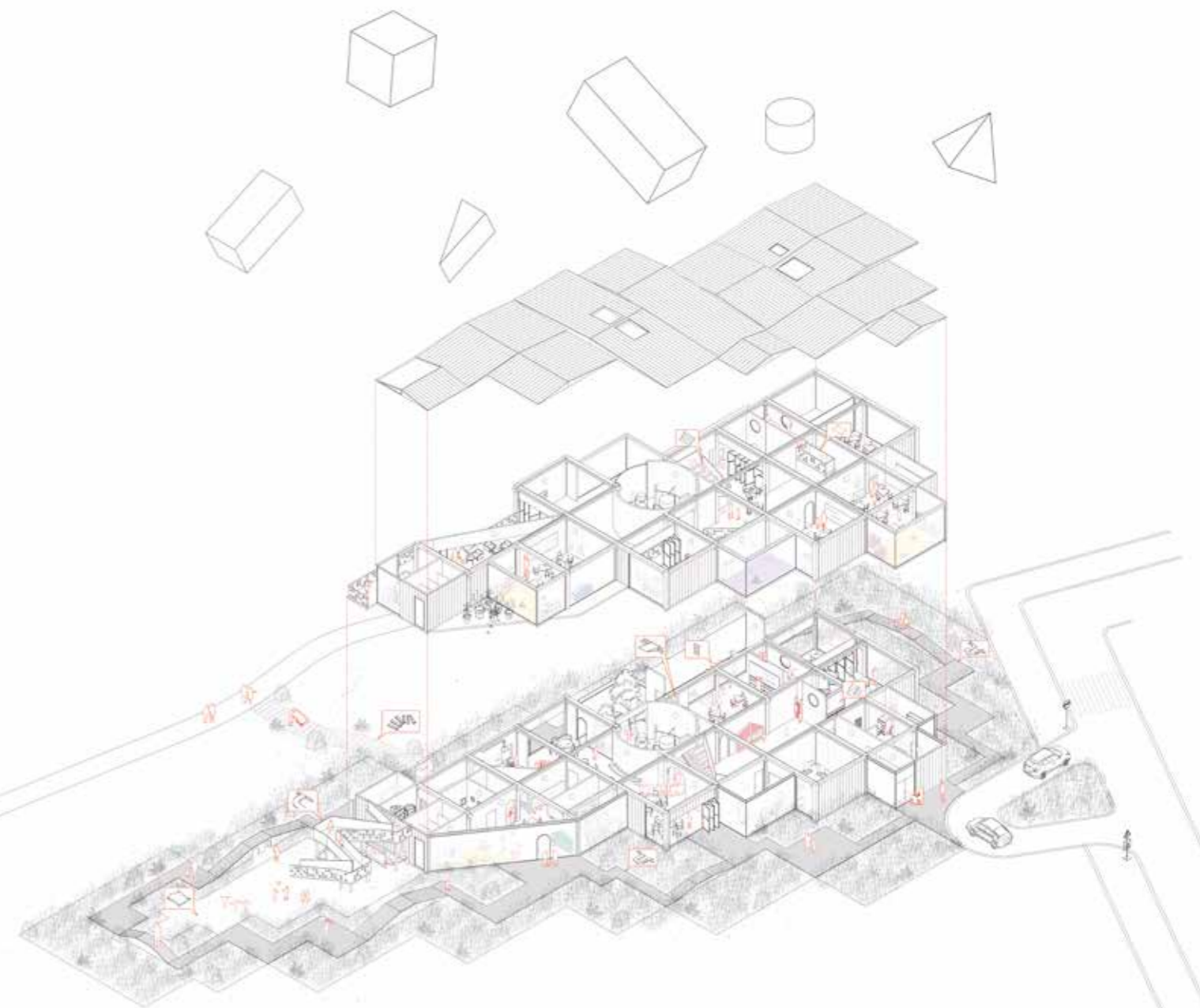



KINDERDORF
 HOW TO CREATE AN ACTIVE
 KINDERGARTEN ENVIRONMENT

Nicole Hooi Yi Tien
 DIA Master Architecture Studio SS 2019
 Supervisor: Prof. Dr. Natascha Meuser

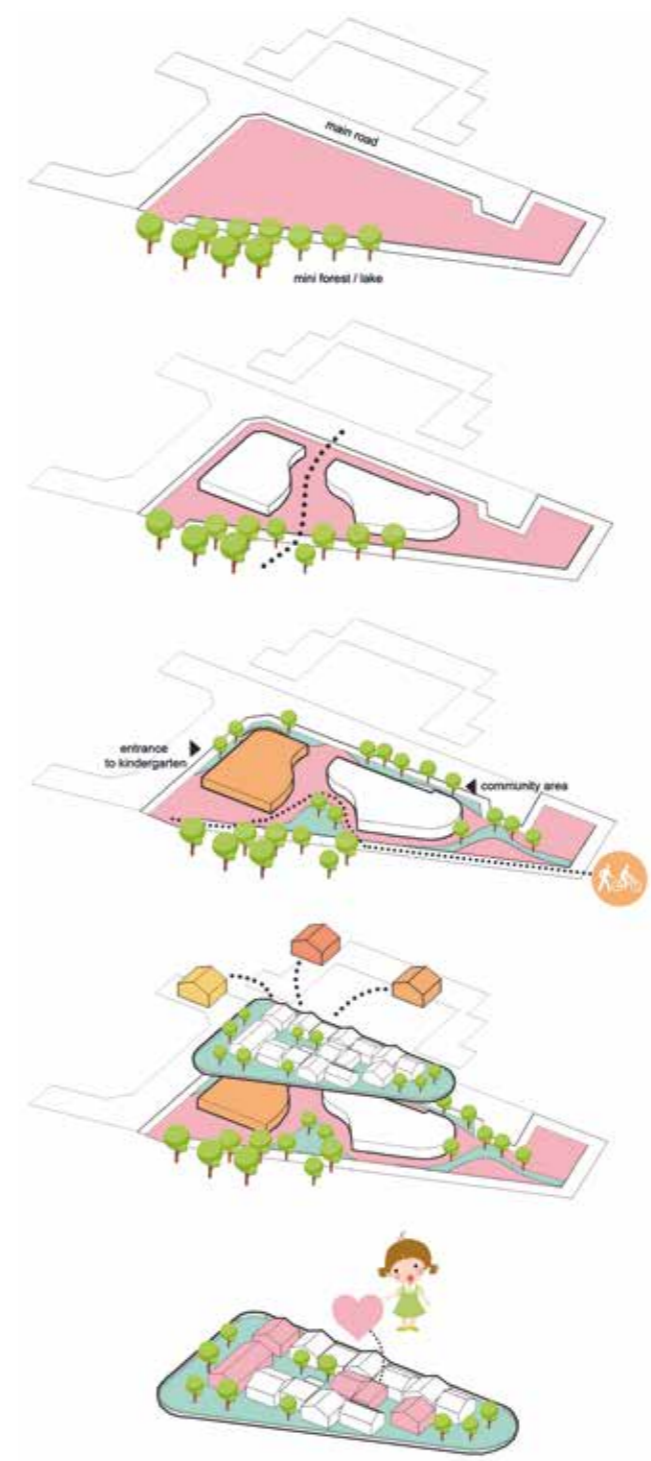

Community Space
 The site lies between a forest, a lake and an established neighbourhood. It has the potential to act as a hub for everyone in the community. By combining a kindergarten, a shopping area and a community space, the project should attract people from all social groups and serve as a junction between the surrounding areas. Furthermore the architecture itself allows for fluid movement through and around it.

Elevated Kindergarten
 The kindergarten is elevated above the community centre. It is a vital place for the community, since it provides a space for its youngest members, as well as giving a purpose to the building. It will inevitably attract families and parents, which will then naturally populate the area. Its elevation gives protection to the children without completely separating the building from the other community spaces.

Roof Village
 The kindergarten itself is split into small buildings, which contain the different facilities. The scale of the houses is oriented around the children themselves. The atmosphere of a village provides a tight bond between the children and their environment, which they can identify with. The houses and the open spaces between them create a natural dynamic of outdoor and indoor play.



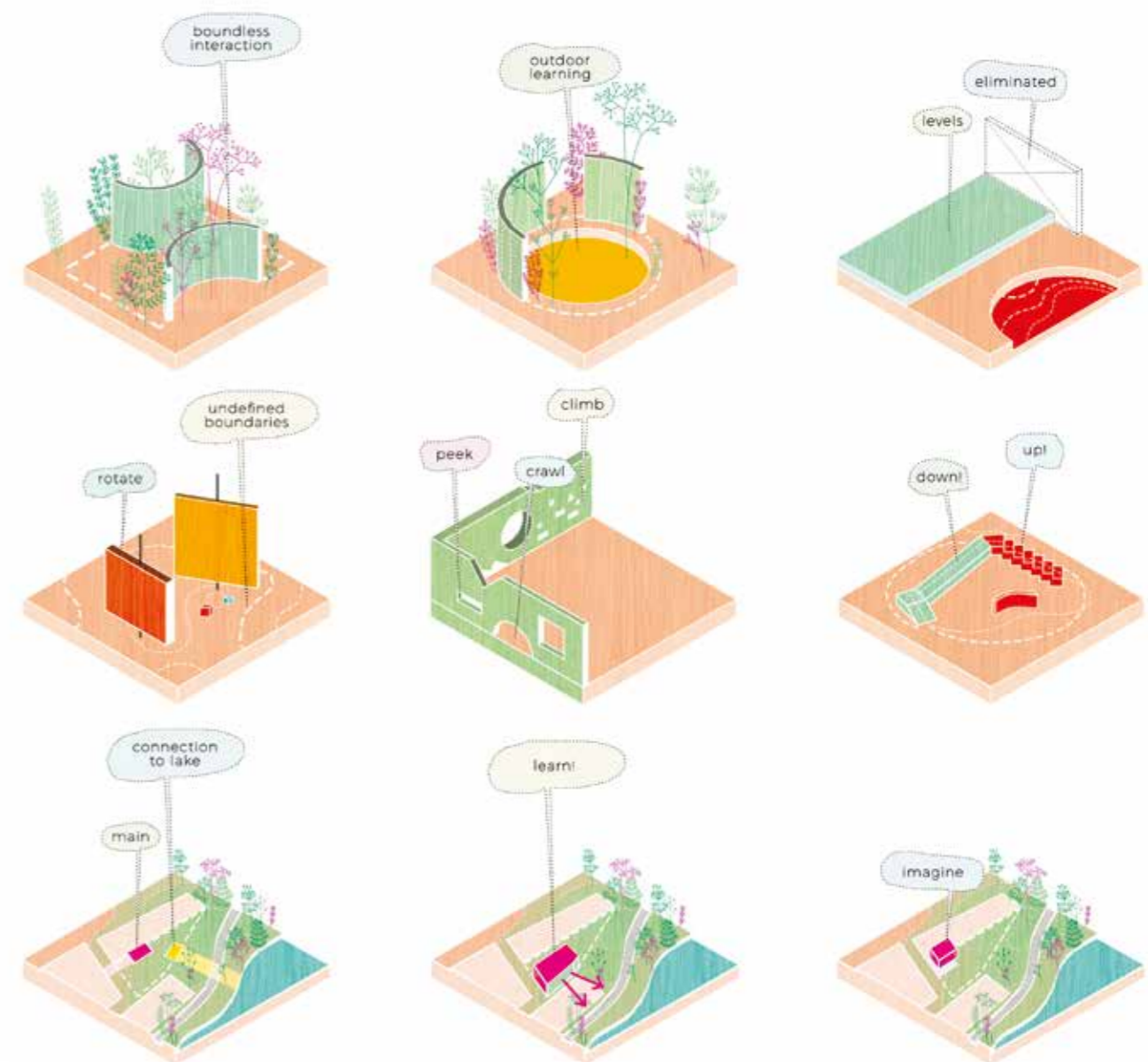

BOUNDLESS KINDERGARTEN
*UNDEFINED SPACE SPARKS
SIMPLE IMAGINATIVE PLAY*

Joyce Yi Qin Wee
DIA Master Architecture Studio SS 2019
Supervisor: Prof. Dr. Natascha Meuser

Redefining Boundaries

Boundless: physically and mentally. By using architectonic elements such as different levels, flexible shelves and punctured panels, my design has redefined the definition of walls. They are stripped of their rigidity to provide endless possibilities for the kids to experience the space. Kids have the ability to redefine their own classrooms every day.

Simple Geometry

Geometry is one element that gives aesthetic value to my design. This principle will define the result of the architectural form of the kindergarten. Simple geometries are put together to bring nature into the interior spaces. Huge circles direct focus towards the space, and blurring boundaries promotes outdoor activities.

Loop of Movement

The circulation of the building flows seamlessly and indefinitely. Vertical circulation involving stairs and slides invites the kids to move around in an infinite loop between floors. They can explore different paths, views and areas. Boundlessness strengthens the connection between spaces and sparks interaction amongst the kids.

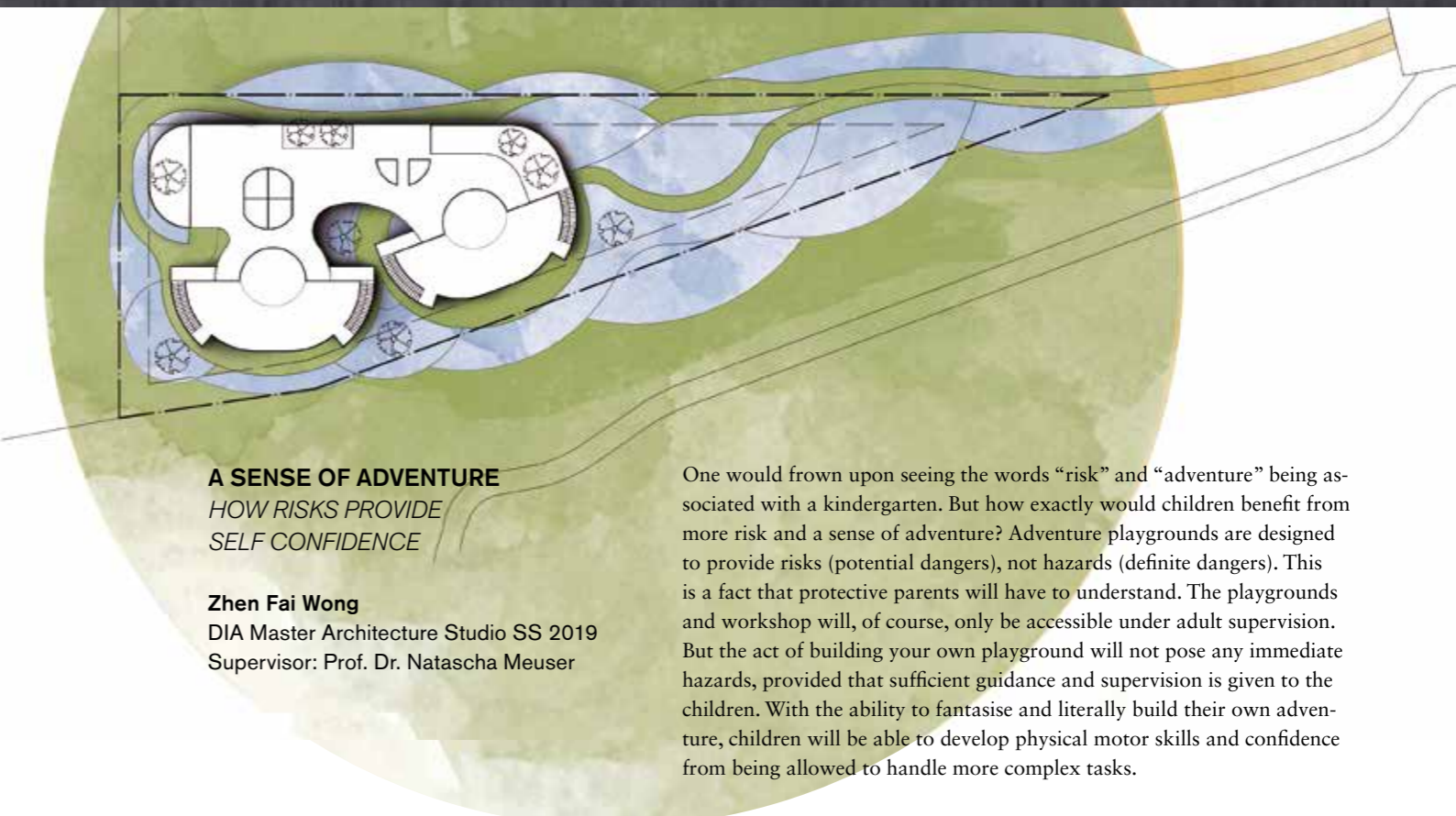
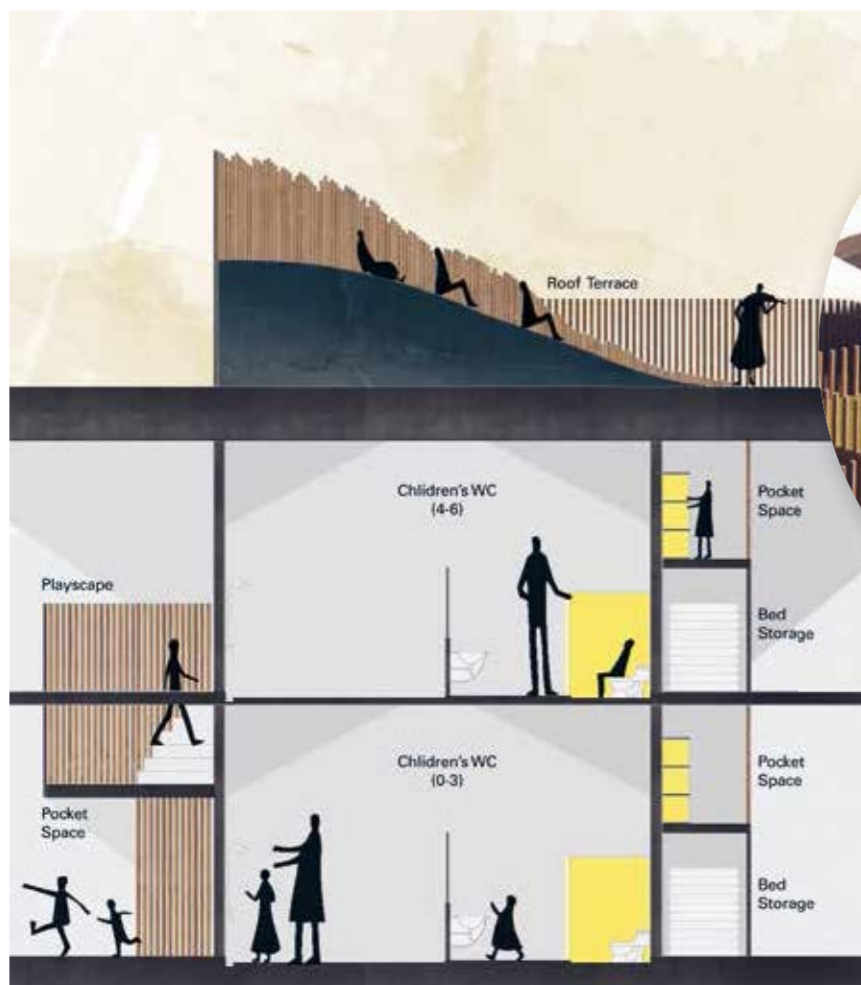

A SENSE OF ADVENTURE
*HOW RISKS PROVIDE
 SELF CONFIDENCE*

Zhen Fai Wong
 DIA Master Architecture Studio SS 2019
 Supervisor: Prof. Dr. Natascha Meuser

One would frown upon seeing the words “risk” and “adventure” being associated with a kindergarten. But how exactly would children benefit from more risk and a sense of adventure? Adventure playgrounds are designed to provide risks (potential dangers), not hazards (definite dangers). This is a fact that protective parents will have to understand. The playgrounds and workshop will, of course, only be accessible under adult supervision. But the act of building your own playground will not pose any immediate hazards, provided that sufficient guidance and supervision is given to the children. With the ability to fantasise and literally build their own adventure, children will be able to develop physical motor skills and confidence from being allowed to handle more complex tasks.



North elevation



West elevation

Section BB



Ground floor

- | | | |
|------------------|---------------------------|------------------------------|
| 1 Entrance | 8 Playhouse | 15 Child health care |
| 2 Office | 9 Group room kindergarten | 16 Sauna |
| 3 Staff room | 10 Parents area | 17 Group room crèche |
| 4 Dining area | 11 Multipurpose space | 18 Stroller and pram storage |
| 5 Equipment room | 12 Staff area | |
| 6 Kitchen | 13 Gallery | |
| 7 Store | 14 Workshop | |

PÄDAGOGIK IN DER PLATTE
FRÖBEL KINDERGARTEN BERLIN

Fanguan Zhang
DIA Master Architecture Studio SS 2018
Supervisor: Prof. Dr. Natascha Meuser

This seminar explored nursery schools and childcare facilities from an architectural perspective. The aim was to provide a cultural-historical account of the development of educational buildings for children, to define design tasks, and to formulate quality standards. Students developed, through guided research and methodical design, planning parameters as well as models for organising space. They then implemented and present these parameters and models in a design of their own.



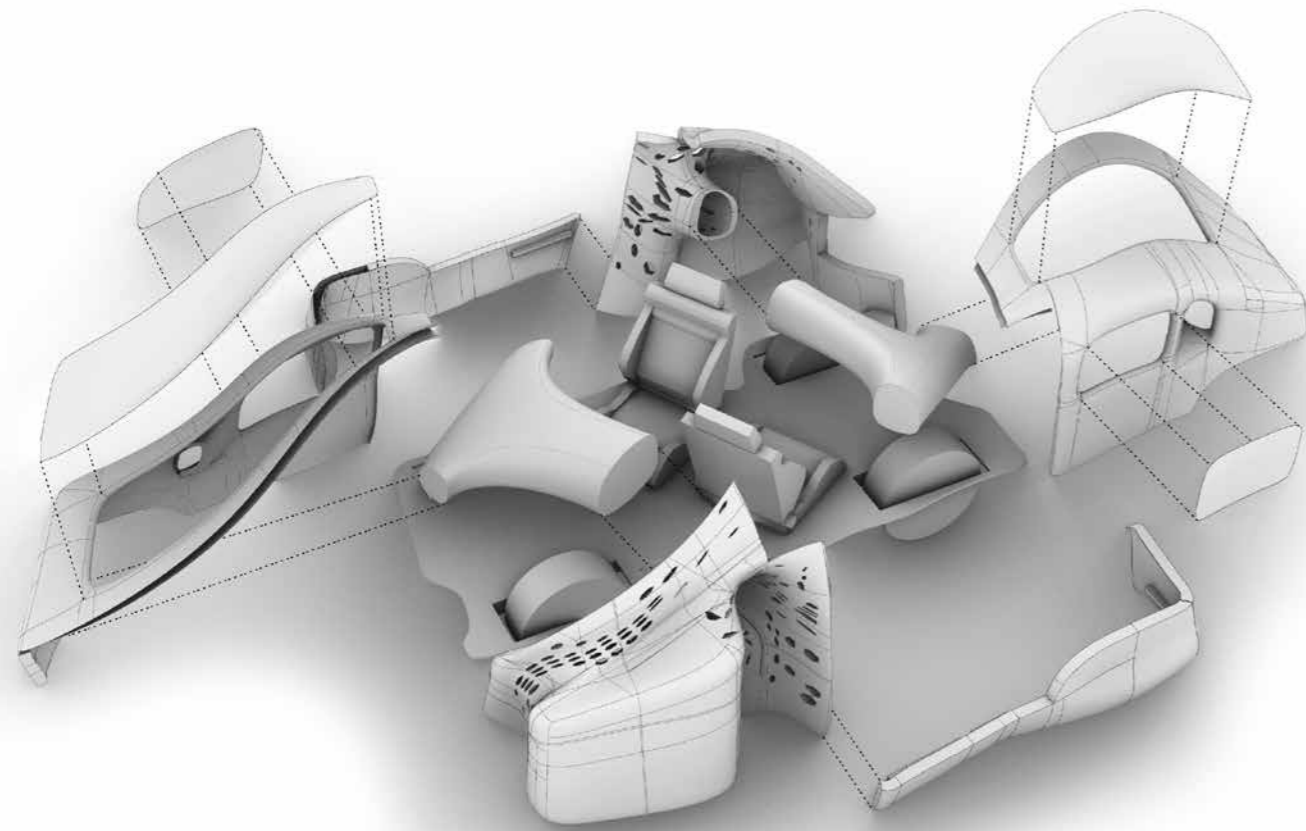

ADAPTIVE CITY CAR

Saeed Abdwin, Aleksander Mastalski, Neady Oduor, Marina Osmolovska, Niloufar Rahimi, Josephin Latha Ashish Varshith (DIA)

Jan Boetker, Otto Glockner, Nate Herndon, Lam Sa Kiu, Dominique Lohaus, Marie Isabell Pietsch, Katja Rasbasch, Fu Yi Ser, Anian Till Stoib, Laura Woodrow (DDD)

DIA Master Architecture SS 2019

Collaborative studio between DIA (Dessau International Architecture Graduate School) and DDD (Dessau Department of Design)

Supervisors: Prof. Dr. Manuel Kretzer (DDD), Sina Mostafavi (DIA)

Supports: Mike Herbig, CG Artist, Mohammed Mansour (Audi), Carl Buchmann (Robotic Lab), Esteban Amon (Video)

“Adaptive City Car” is a collaborative project between designers and architects sponsored by Audi. Over three months of continuous research, design and prototyping, the interdisciplinary team designed and produced a full-scale model of a new type of city car. The project merges adaptive systems, nature and digital design with robotic fabrication to provide a more user-friendly and customized car for the near future of our cities.

We live in a time of massive societal and environmental change. Our tasks as designers and architects are to address these challenges and develop innovative and sustainable solutions for the future. Especially within the urban context, we are seeing growing demand for eco-friendly solutions in transportation and the built environment. In this context, “Adaptive City Car” is a joint project studio between the design and architecture faculties in Dessau, which explores and provides new solutions for mobility in the cities of today and the near future.

The design is clustered into various parts and components according to the assembly logic and potentialities of robotic fabrication. Porosity is distributed relative to multiple functions such as integration of smart lighting systems as well as the integration of cork cavities hosting natural plants as air purifiers.

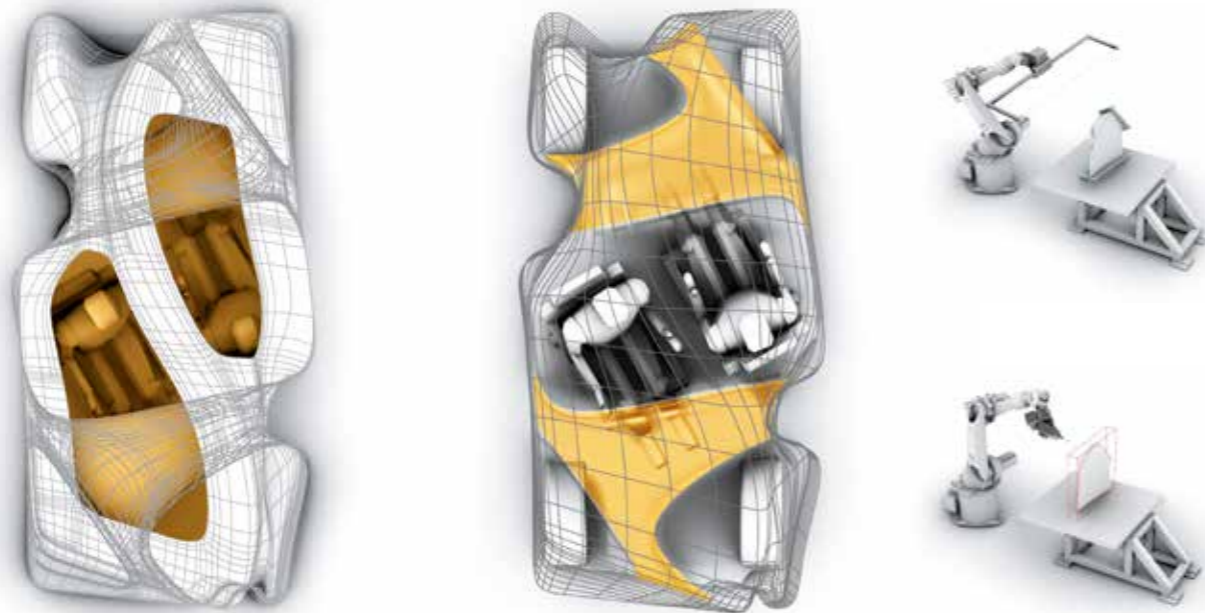

above: Rearrangement of seating position based on human interaction, Interior seating position informs the seamless exterior configuration.
right: Combination of Robotic Hot-wire cutting and Robotic Milling.





“MELT RAY” MUSIC STAGE TABLE
 DESIGN, ARCHITECTURAL ROBOTICS
 AND SYSTEMS (DARS)

Design team: **Muhannad Elmanae, Shazwan Mazlan, Adib Khaeez, Mohamed Abdo Kurani, Ahmed Saleh**
 Fabrication Team: **Md. Mushfique Ahsan, Maged Elbanna, Muhannad Elmanae, Yaseen Jabr, Adib Khaeez, Mohamed Abdo Kurani, Ksenia Lanina, Shazwan Mazlan, Ahmed Saleh**

DIA Master Architecture Studio / Elective Supervisor: Sina Mostafavi

The project “Melt-Ray” is a design for robotic fabrication of part of a 360-degree performing music stage for both Melt music festival and the 100th Bauhaus anniversary. It is designed by M.Arch design studio at DIA Dessau. The team has chosen a proportion of the whole stage in which the main design ideas and characteristics can be distinguished as a stand-alone product or music table stage.

The design evolved through a series of parametric models and is informed by computational analysis and robotic fabrication methods. The interrelationships between elements of the design and the production algorithm are derived based on user requirements, such as a deck for one large and one medium instrument with a load capacity of up to 60 kg. Provision is also made for built-in loudspeakers and an integrated light design. Incorporating multiple fabrication possibilities, a network of volumetric meshes of varying thicknesses is generated. The thickness is determined based on structural analyses as well as functional requirements. Using a genetic algorithm or an evolutionary solver, each piece is oriented and rotated three-dimensionally to perfect the surrounding box, thus minimising material waste. Consequently, 21 unique components are cut one by one and tagged for the assembly process. The entire process took around 60 hours. By the end of the fabrication phase, the team had started to assemble the pieces. We used a combination of foam and wood glue to connect the pieces in the best way. The overall volumetric free-form body of the table is coated with two layers of fiberglass reinforced with resin.

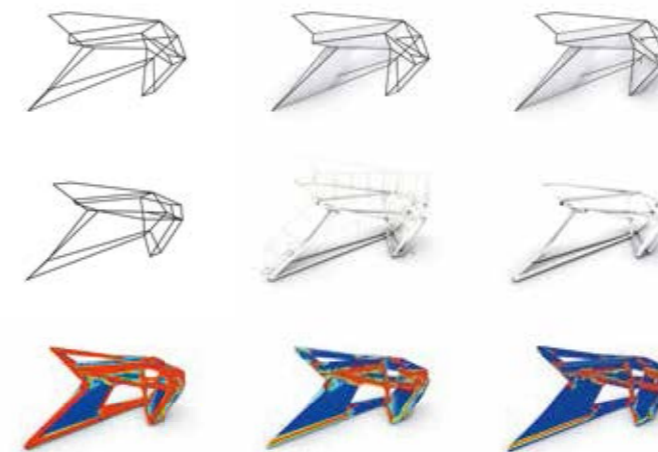

- Step 1 Line to Volume
- Step 2 Structure Analysis
- Step 3 Surface Curvature Analysis

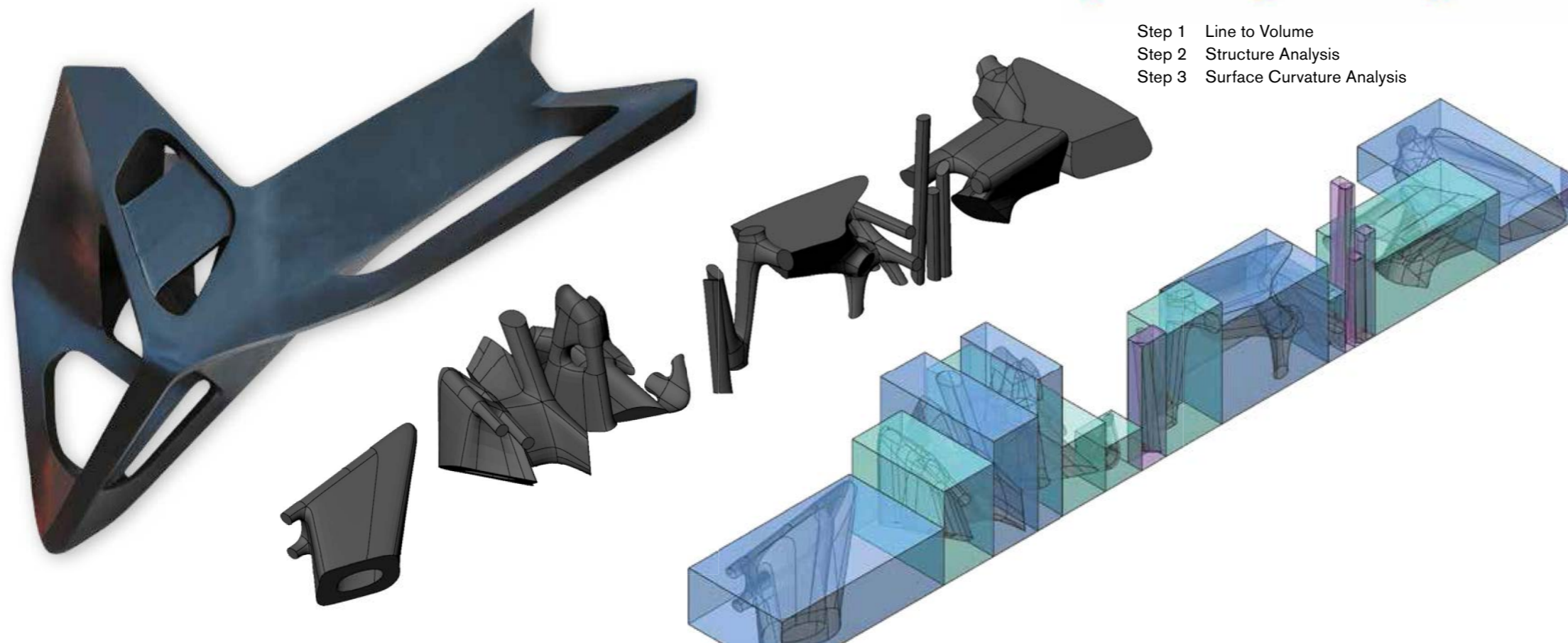



BIOPLASTIC ROBOTIC MATERIALIZATION

DESIGN TO ROBOTIC PRODUCTION OF BIODEGRADABLE LAMPS

DIA Master Architecture Studio SS 2018
Supervisors: Sina Mostafavi,
Prof. Dr. Manuel Kretzer,
Mohammed Saad Moharram, Arise Wan

Fotos: Sina Mostafavi
linke Seite (Reihe von links nach rechts)

1 Second Skin

Amro Hamead, Quenna Leer,
Dominique Lohaus, Johanna Müller,
Neady Oduor

2 Lifelight

Kamal Amgad Mohamed Zaki, Jason
Hage, Adib Khaeez, Martin Naumann,
Luise Eva Maria Oppelt, Julia Ziener

Recent advances in digital design and robotic material creation have introduced innovative methods for the realization of complex geometries and direct experimentation through physical prototyping. The flexibility and programmability of such techniques enable the implementation of alternative materials in various scales ranging from product design to building processes. In this context, architectural robotics, as an emerging field, provides a novel means of incorporating informed materiality in building methods and products. Consequently, in the particular context of working with bioplastic, the efficiency of the design can be achieved by exploring and engineering the complexity of material distribution and controlling the degradability level.

The overall learning goal of this project was twofold. On the one hand, the goal was to find and develop the proper method of robotic fabrication for each material recipe and project. On the other hand, through systematic experiments with bioplastic, the aim was to develop the perfect material recipes for different robotic production methods. Following a phase of experimental research, the overall goal was to design and robotically produce lampshades made from self-made bioplastic material. According to the outcomes of the experiments and design explorations, relevant techniques of robotic fabrication such as multi-mode, subtractive and additive manufacturing were used.





BAUHAUS 100 PAVILION
METAL PROJECT

Kamal Amgad Mohamed Zaki, Kyanoush Bitarafan, Jason Hage, Antonio Herrera, Amro Hamead, Adib Khaeez, Gulfia Kutlahmetova, Mohammed Mansour, Vidhya Trinity Venugopal

DIA Master Architecture Studio WS 2018/19
Supervisor: Sina Mostafavi

At the Bauhaus, form followed function and ornamentation was banished. The aim of this radical simplification was to merge crafts with the modern technology of the time. As a concept for the use of materials and geometry in our project, we moved to today's machine capabilities, while synthesizing the materials to be used: customization. The materials in question here are concrete, EPS and metal. Many obstacles have been faced throughout this process, relating to the materiality of the pavilion, the form-finding process, the functionality or the architectural aesthetic. To get along with the work, many trials have been implemented, and learning outcomes were drawn from past student works as well as professional precedent projects. Based on the circulation, the gradient of the views starts mainly with the immediate surrounding and direct visual connection, until the user starts approaching the turn towards Bauhaus Straße, when suddenly the focal point becomes the Bauhaus institute, even as it is aligning with the background of the promenade.

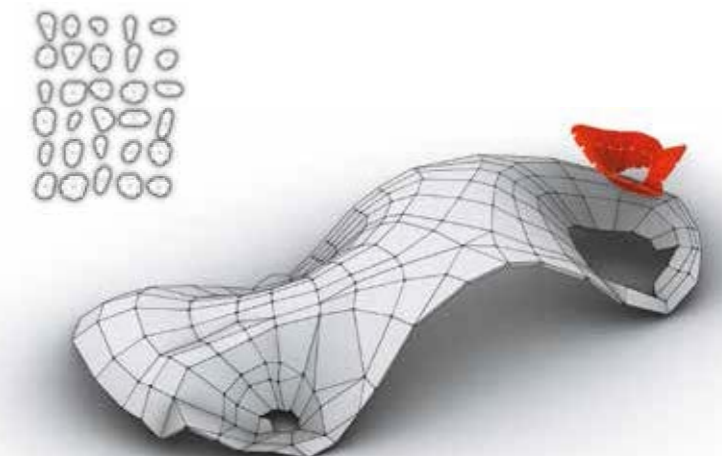
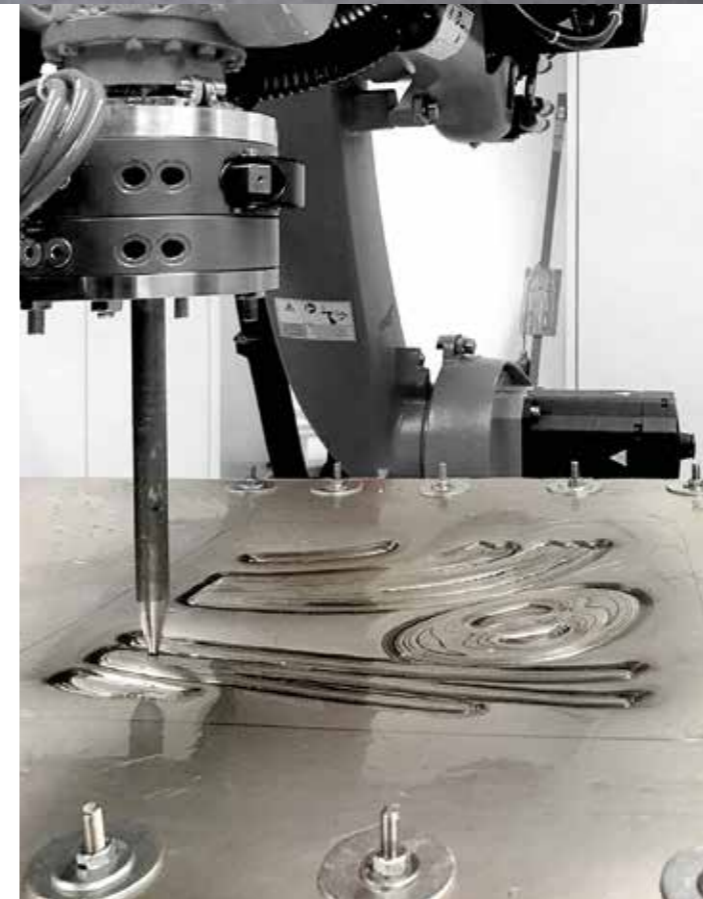
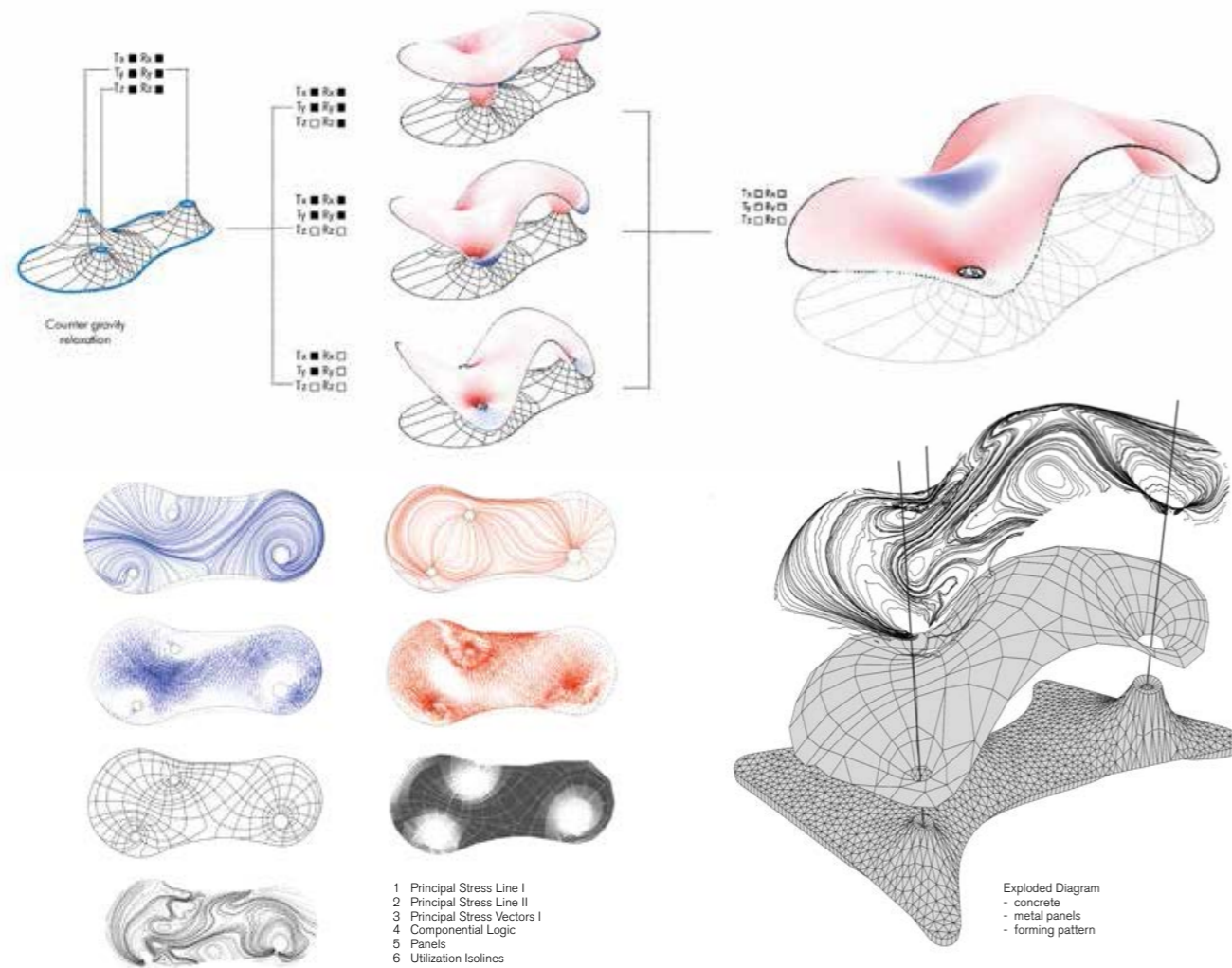



Final Pattern

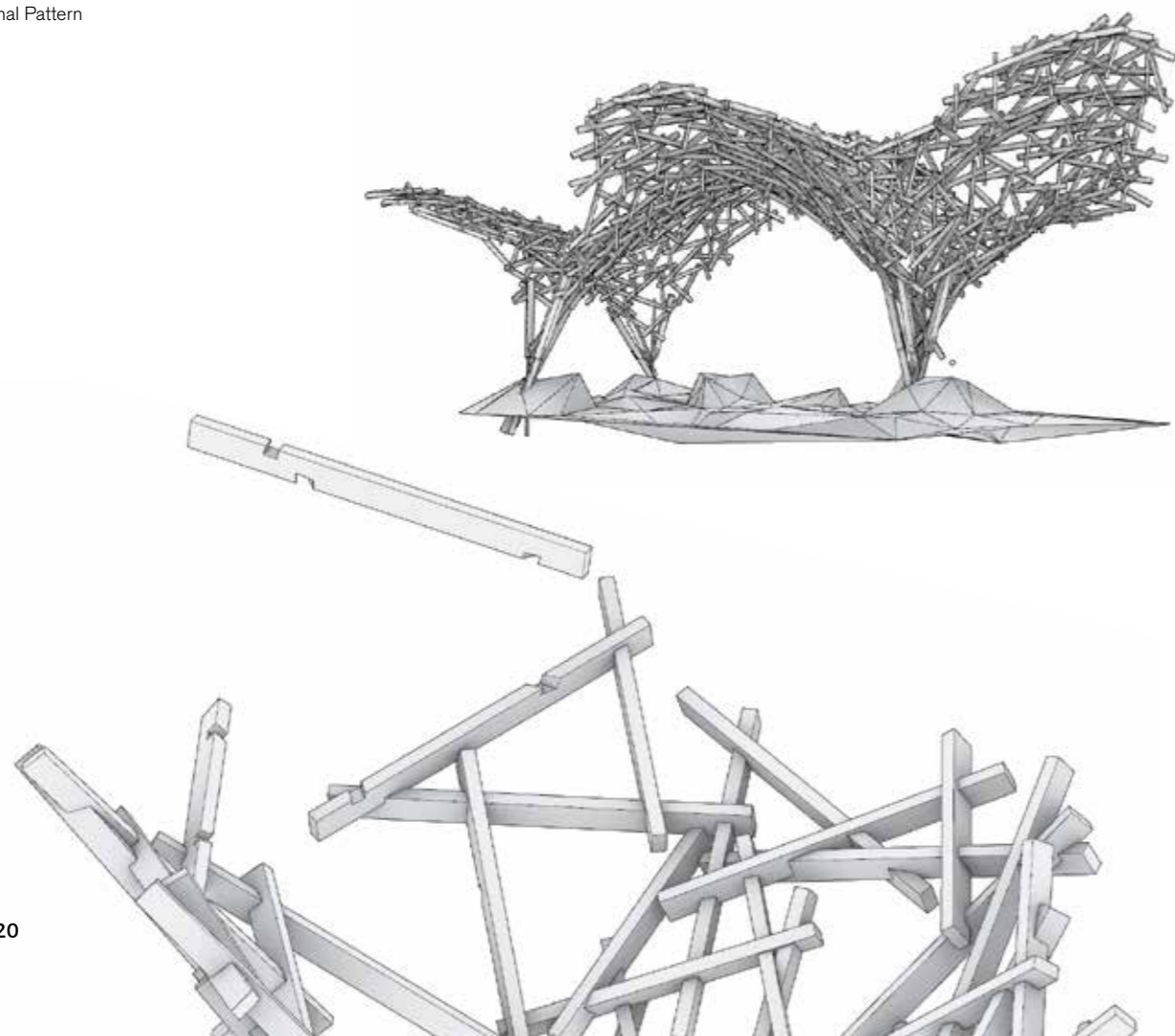

BAUHAUS 100 PAVILION
WOOD PROJECT

**Mushfique Ahsan, Hossam Badr,
Maged Elbanna, Yaseen Jabr,
Valmir Kastrati, Shazwan Mazlan,
Queena Ler Mei, Sabrina Ortiz,
Karsimran Singh**

DIA Master Architecture Studio WS 2018/19
with collaborative workshops and parallel
studios at Delft University of Technology
Supervisor: Sina Mostafavi



Formfinding

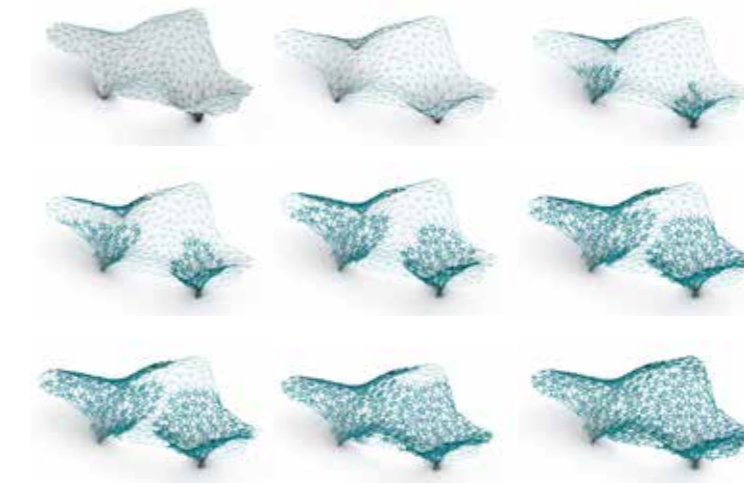

Mathematical Reciprocal Structure

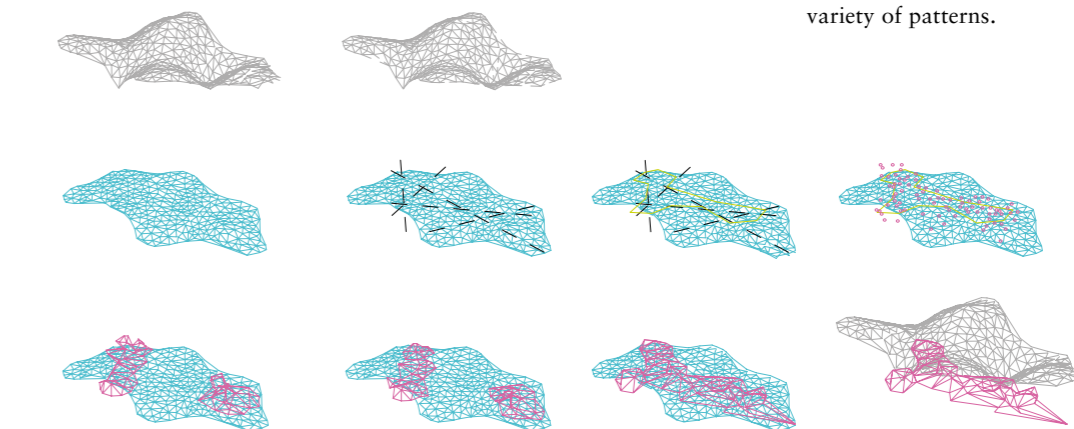

Anchor Study

Commemorating the 100th anniversary of the Bauhaus School, the Dessau International Architecture Master students of Anhalt University designed the robotically produced wooden pavilion located in Dessau-Rosslau, Germany. The location of the proposed pavilion is close to the iconic Bauhaus building and to the university campus.

The following research is based on the idea of the reciprocal timber structures as a constructive system and its applications. However, the proposed system does not correspond completely to the rules of a typical reciprocal system, in terms of generative rules or elongation of the connecting members of the fans (units). Instead, a semi-reciprocal approach is explored. The reciprocal frame is a three-dimensional grillage structure mainly used as a roof structure and consisting of mutually supporting sloping beams placed in a closed circuit. The inner end of each beam rests on and is supported by the adjacent beam. At the outer end, the beams are supported by an external wall, ring beam or by columns. This creates an interesting structural system that results in a variety of patterns.

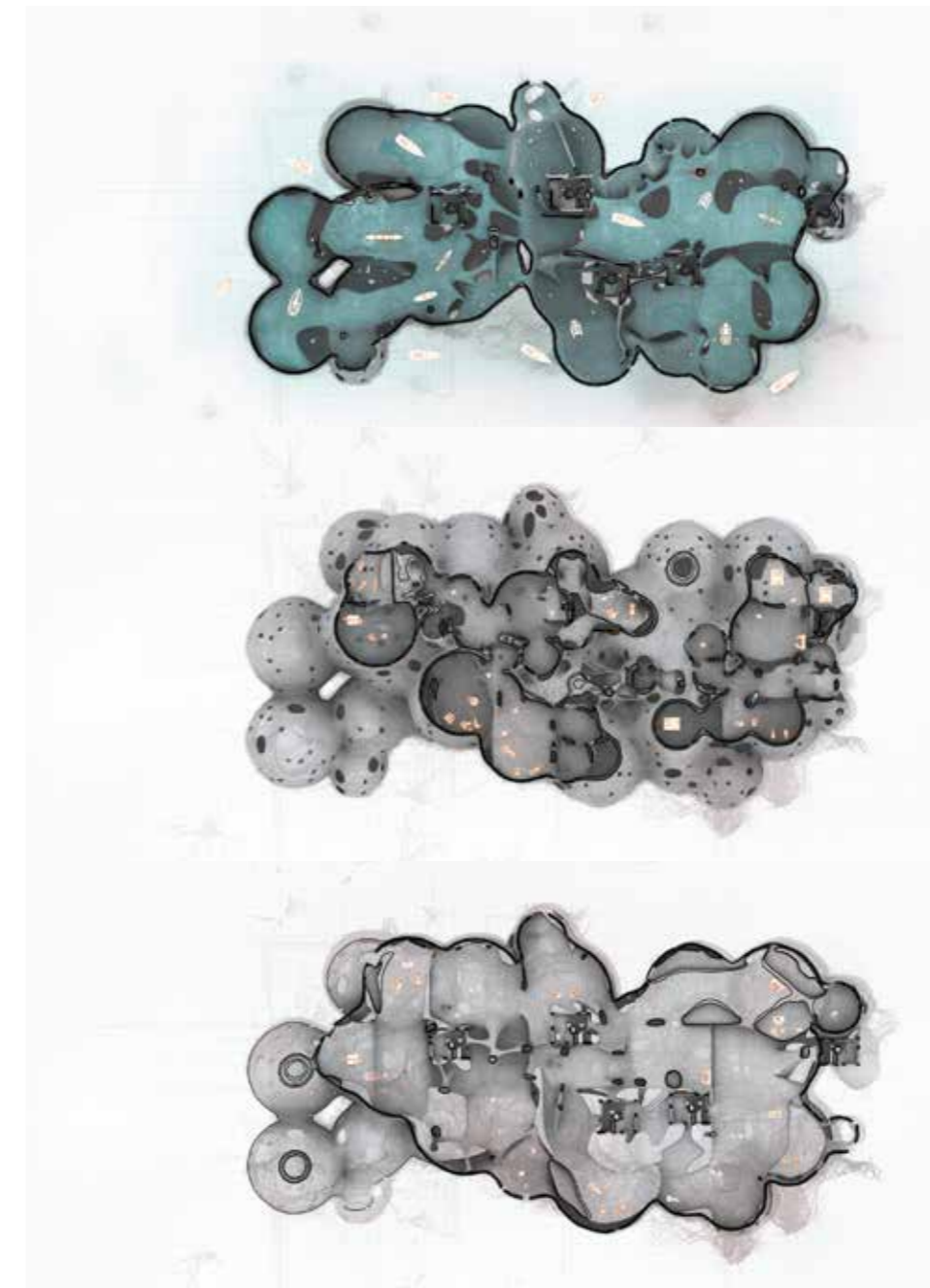
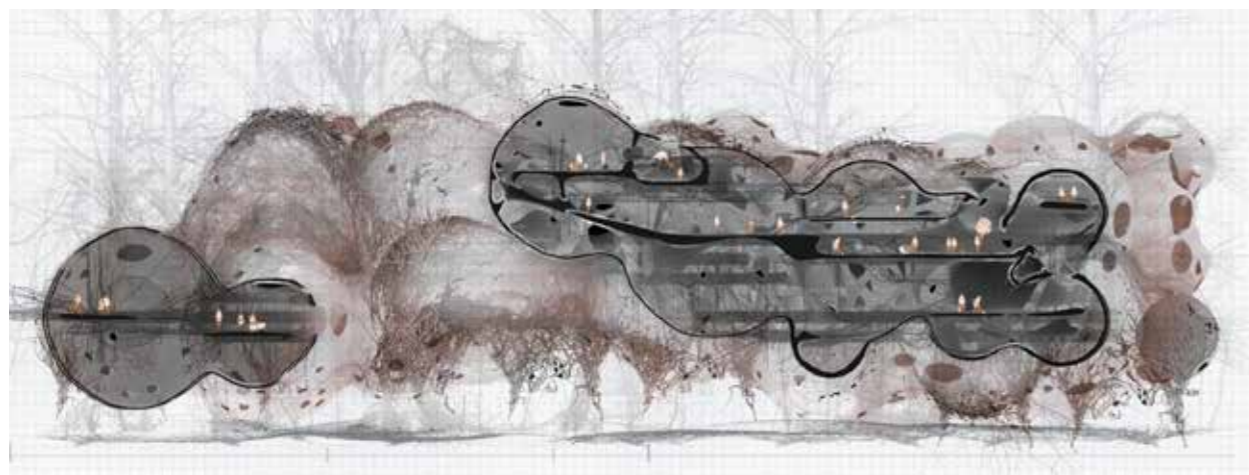

BIOTOPE GENERATIVE SYSTEM
 STRATEGY FOR INTEGRATING
 CONTEMPORARY HOUSING
 COMMUNITY WITH NATURE IN FLORIDA

Mohammed Mansour
 DIA Master Architecture Thesis SS 2019
 Supervisors: Sina Mostafavi,
 Prof. Dr. Manuel Kretzer

Climate is changing
 Humanity is no longer the sole organizer of matter and space. Global warming and the ongoing destruction of the planet is putting humankind at the mercy of nature. The debate linked to more responsive architecture that is connected to nature has been growing since the 1960s. Notwithstanding this fact up to now, architecture is somewhat conservative: following the same principles with the belief in rigidity, solidity, and levity. This is why we need to change this mindset for the rigid and static architecture and start building with nature. By that, I mean the actual implementation of living matter where nature becomes an inherent part of the design process, and life becomes a building material.
 My thesis begins by predicting the state of the earth in the year 2100. Warming from anthropogenic emissions from the pre-industrial period to the present will persist for centuries to millennia and will continue to cause further long-term changes in the climate system, such as the rise of sea levels and consequently the sinking of coastal cities with associated impacts (high confidence), but these emissions alone are unlikely to cause global warming of 1.5°C (medium confidence).

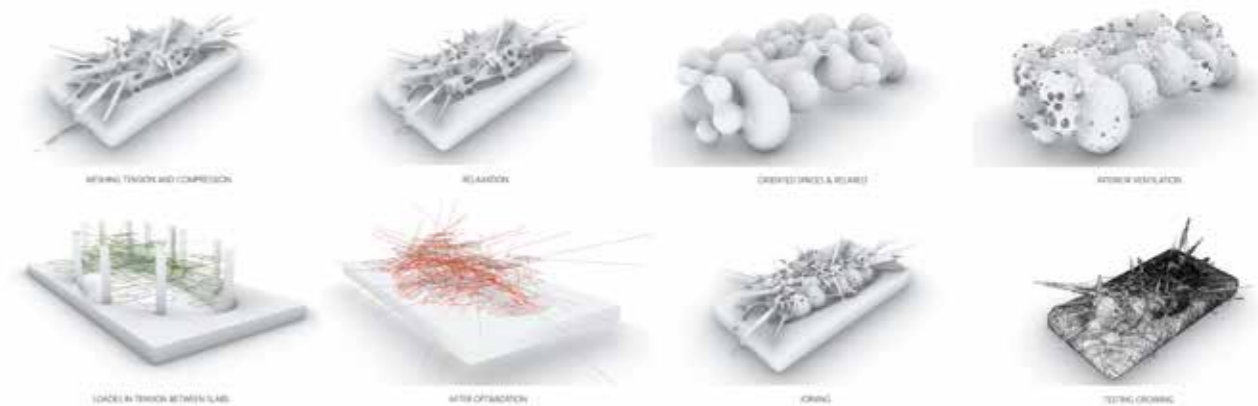

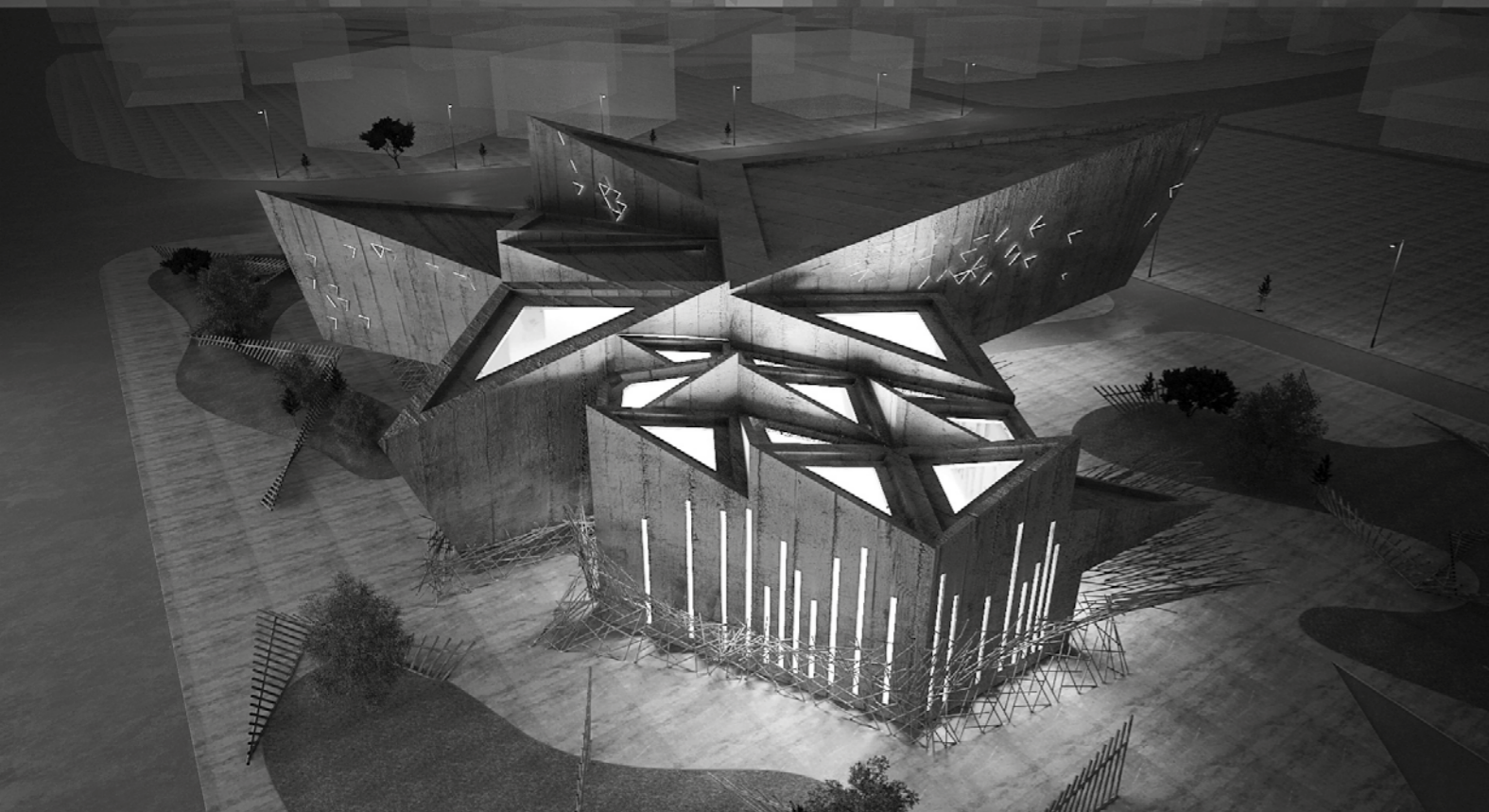

Space Syntax

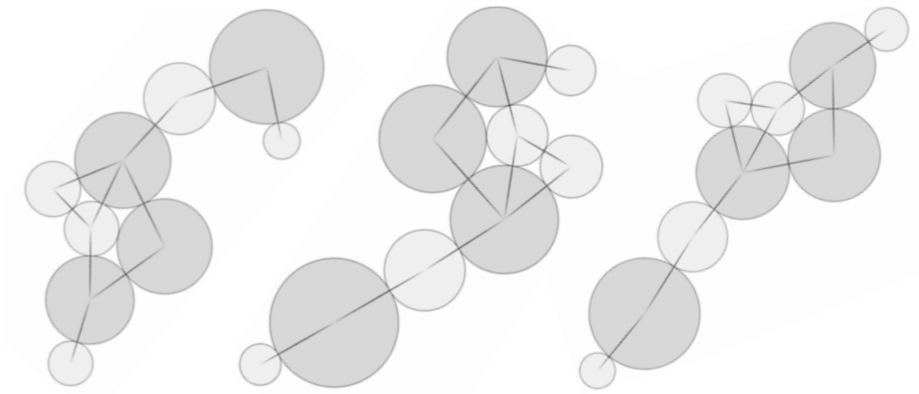

Selection Boundary

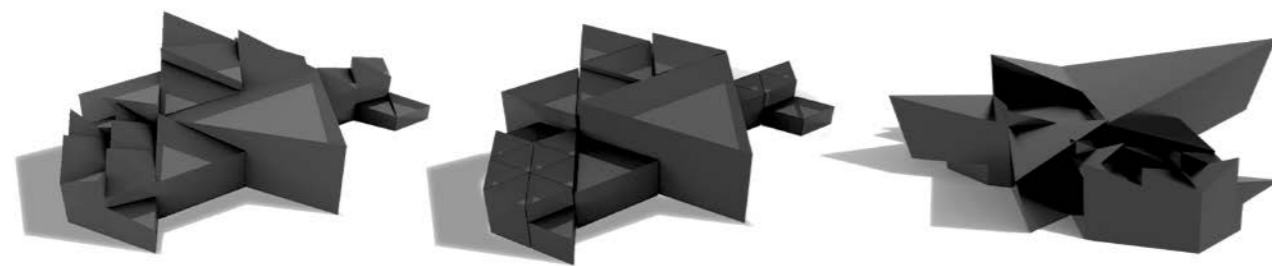
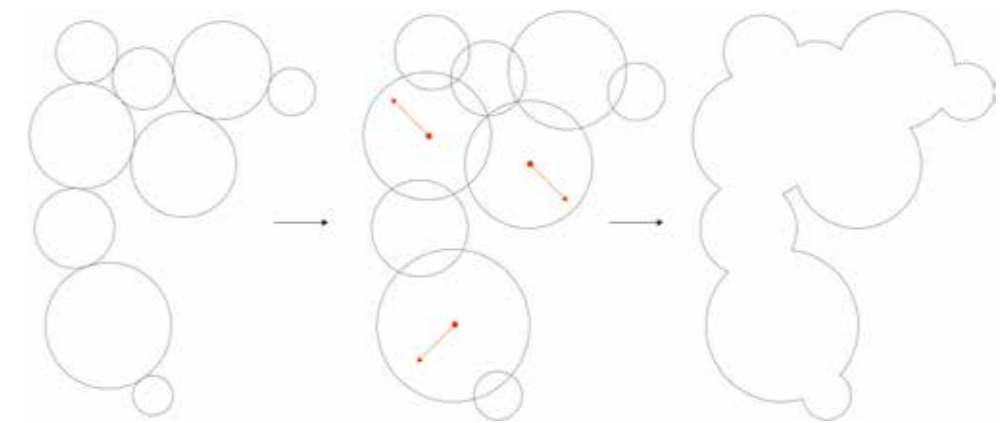

Evolutionary Process

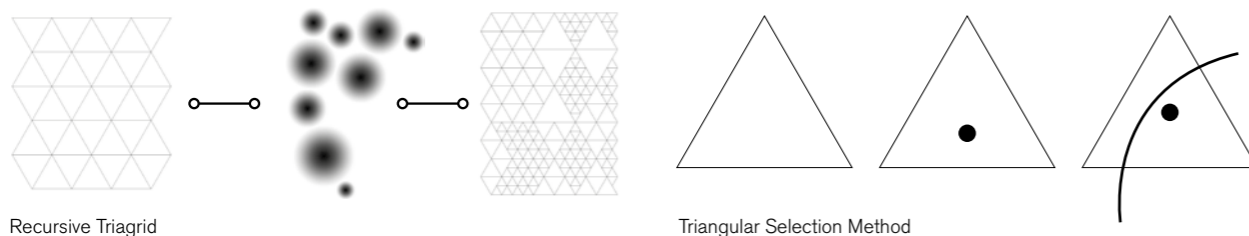

Recursive Triagrid

Triangular Selection Method

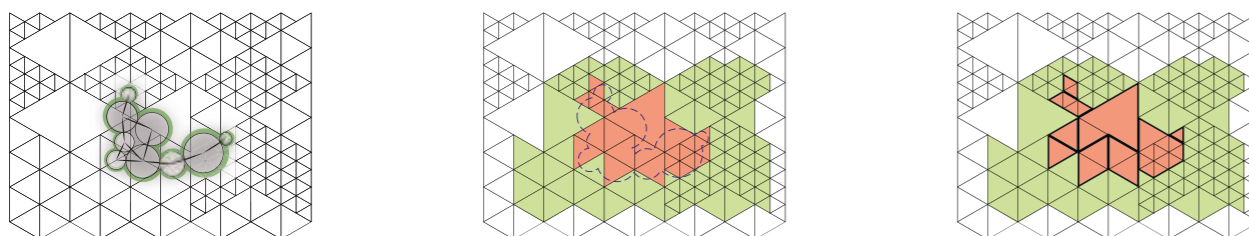

Selected Triangles

ACOUSTIC OPERA AND BALLET HALL PRISTINA

Valmir Kastrati

DIA Master Architecture Thesis SS 2019

Supervisors: Sina Mostafavi,
Prof. Dr. Manuel Kretzer

We started our research semester by designing a pavilion under the heading “100 years of Bauhaus”. This research leads us to ideas on how to approach our individual projects and how we can use design tools, materiality, and robotic fabrication techniques based on pavilion research. In my case, this research led to new development techniques for wood fabrication and structural techniques. The model we developed was a reciprocal structure which will be used as part of the materiality of my thesis project. By looking into the paradigm shifts in terms of design and geography, I came up with the idea of using one of the future development plans of my home city Pristina, in Kosovo,

which is to build the new opera house with a capacity of 400 seats. The project starts by analysing how the modernist paradigm shifted into our country (the former Yugoslavia), where the dominating style was Brutalism, as we know it today. Numerous concrete buildings of all shapes were built, where nowadays it is a unique style that everyone recognizes as part of our cultural heritage. By looking into this style of architecture, the general plot of my project is to combine some key factors of my research and come up with an interesting design. It should resemble the design style of Brutalist architecture in a contemporary way, combined in a very radical way with wood, as part of our last semester’s research, by using evolutionary algorithms to design a system, instead of designing itself. The design leads to an interesting solution which is developed by evolutionary algorithms, where we teach the algorithm to give us results based on key factors learned from Brutalism. These factors are called objectives, which result in unique designs based on the other parameters referred to as genomes.

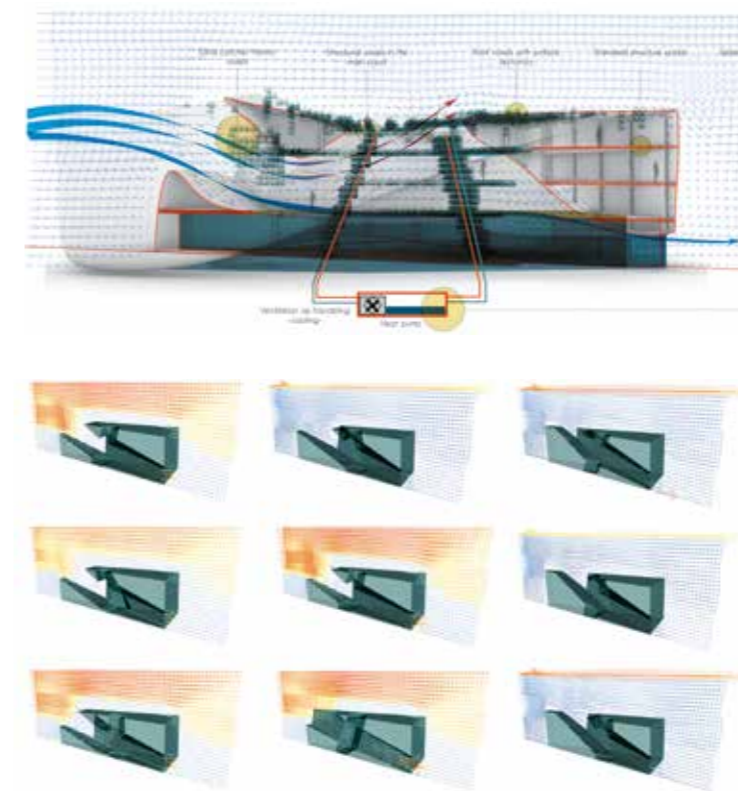
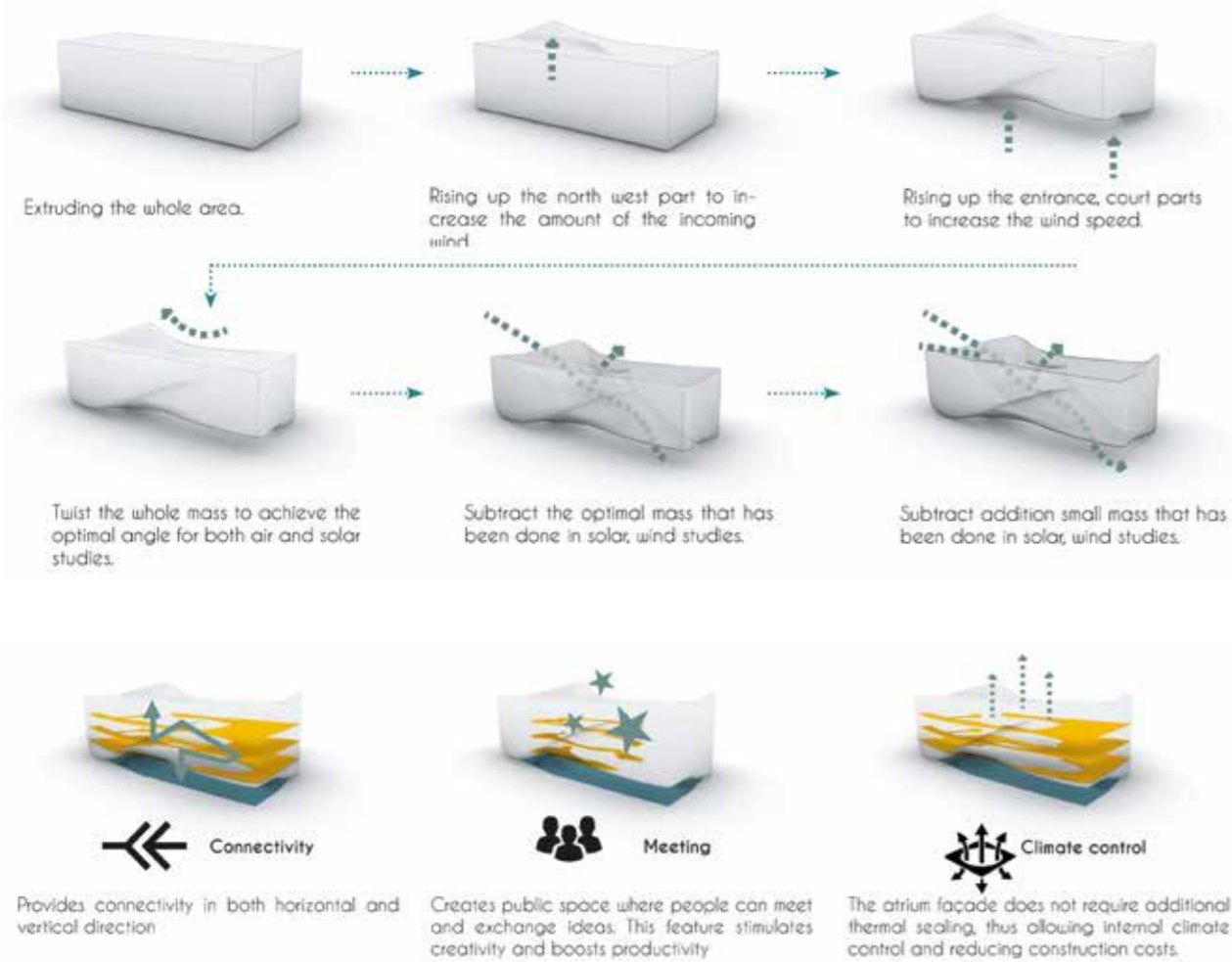

THERMOPOLOGY SKIN
*THERMAL ADAPTIVE BUILDING
STRUCTURAL SYSTEM*

Amro Hamead
DIA Master Architecture Studio SS 2019
Supervisors: Sina Mostafavi,
Prof. Peter Ruge

This research project includes an environmental design for the Cairo University Robotic Building in Sheikh Zayed City in Cairo, Egypt. It shows the responsiveness of digital design to the environmental requirements through the architectural vocabulary. The recently developed generation of high-performance skins contributes greatly to the emergence of innovative manufactures integrating real-time environmental response. The aim of the project is to discuss design strategies used in constructing adaptive building envelopes of multi-storey buildings, integrating improved energy performance and architectural innovation, in order to control the physical environmental factors (heat, light, sound). On a smaller scale, the research aims to merge two simultaneous research tracks into a single project by integrating incremental forming with the adaptive industrial robot control system to refine and advance both research trajectories.

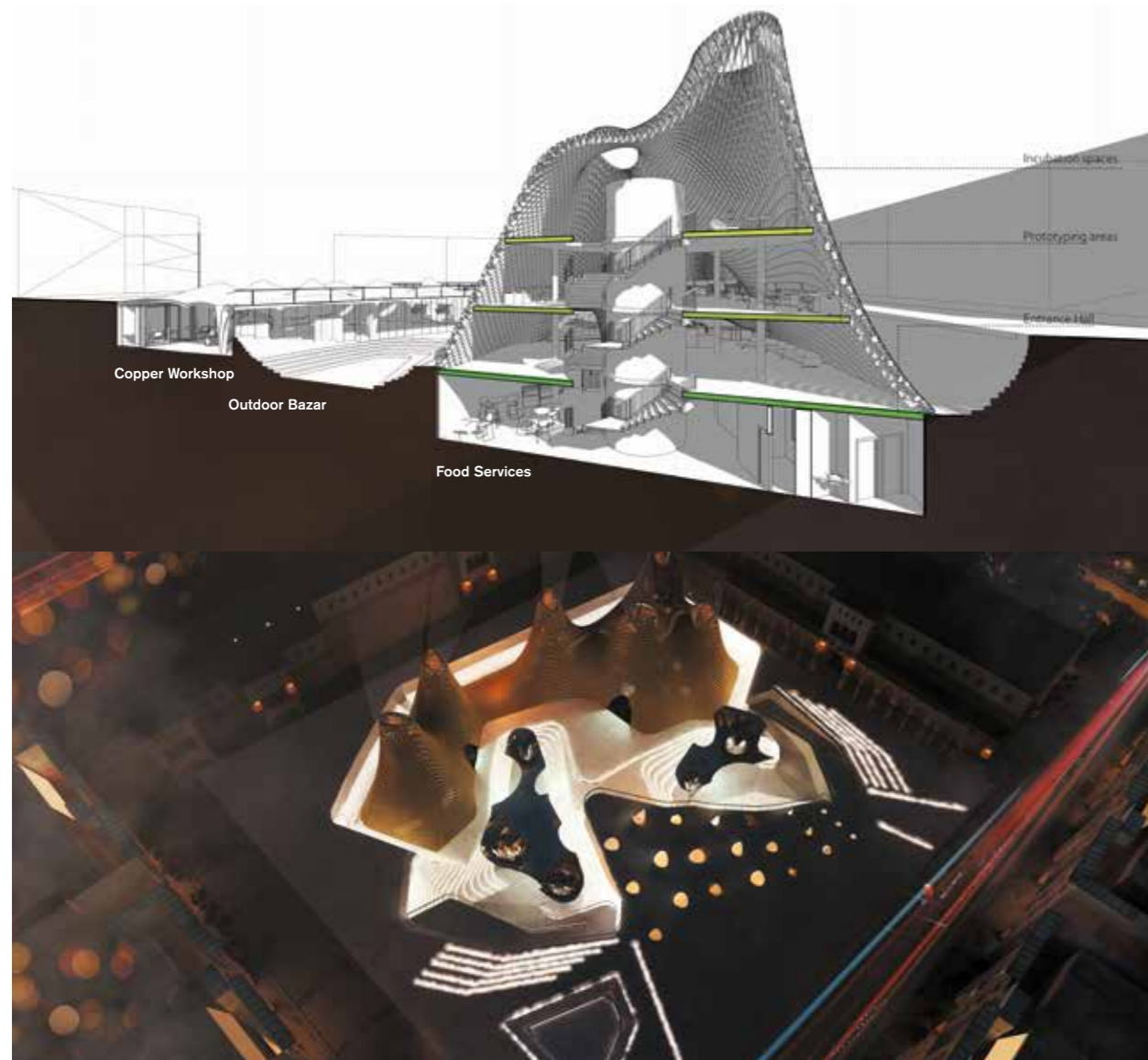

THE COPPER HUB
 STRATEGY TO REVIVE THE COPPER
 CRAFTS IN OLD CAIRO

Kamal Amgad Mohamed Zaki
 DIA Master Architecture Thesis SS 2019
 Supervisors: Sina Mostafavi, Eric Helter

Traditional Egyptian crafts are part of Egypt's intangible heritage, history, legacy and identity. Nevertheless, they are in danger of becoming extinct, though with support they could be a major source of revenue and pride for Egypt's population. Located in the dense historical streets of Fatimid Cairo, a longitudinal path traces the heritage of Cairo and can benefit significantly from a well-developed traditional crafts sector. The cluster of artisanal workshops is indeed one of historic Cairo's major strengths and advantages. If properly developed, it will help both the local community and the entire country. This Copper Hub project will develop strategies to revive the copper crafts in old Cairo both through ephemeral structures and through architecture that refers to heritage and artisanship.

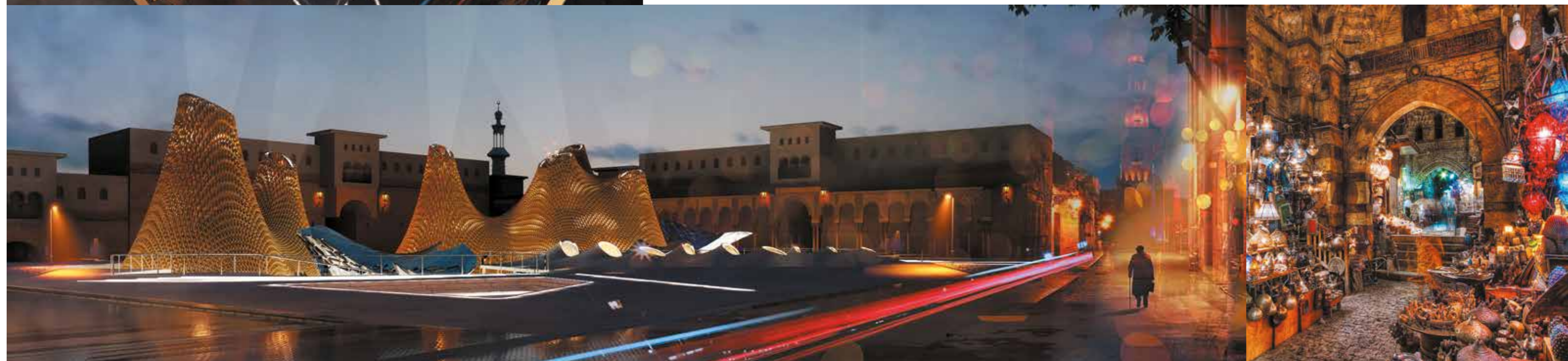

THE USE OF MAPPING AS A COMMUNICATION TOOL IN URBAN TRANSFORMATION

ENVISIONING FUTURE SCENARIOS FOR ZK/U

DIA Master Architecture Studio WS 2018/19
Supervisor: Dr. Natasha Aruri, Dr. Andreas Brück

Urbanisation is one of the most complex and important challenges of the 21st century and a defining process for socio-environmental transformation. Tackling the globally unfolding crises hinges on our ability to disrupt current systems and shift power relations at distinct levels and domains towards creating a more equitable everyday existence. The question is how? And what tools can be used to accomplish this? In this studio, we focused on mapping as a tool of analysis and design, and for getting intimate with the site through understanding one's subjectivities and limitations. Just as mapping is never comprehensive, so are our designs for a future that is continuously in the making, yet needs to be made. Along the same lines, this studio sought to create an understanding that the articulation of subjectivities into visions is an exercise of power.

Mapping is – and always has been – a tool for organising the urban environment and an 'act of power' and is therefore political and subjective (i.e. not neutral). It is a tool for communicating ideas and empowerment in terms of framing and appropriating space, its soft and hard elements (people, resources, etc). Ongoing 'democratisation of mapping' through new technologies is deconstructing the creation of maps as an elitist power tool and is making it available to various strata of people as an instrument with the potential to re-define existing power relations and support a citizen-based transformation. However, the fact that many people today are able to map different things (e.g. using online interactive maps) does not automatically translate into directed or progressive action that goes hand in hand with endeavours of professionals such as architects, planners and other professionals within the relevant apparatuses.

In this studio, we discussed how maps do not merely represent the world, but re-describe it. We also discussed how maps can provoke new perceptions of networks, lineages, associations and representations of places, people and power, depending on the perspective and factored elements. A further topic of discussion was how maps not only have the ability to produce spaces but also social relations – who is being represented and in what relations? What roles are the maps implying on those named and involved? As a tool to

project desires and future urban visions, the power of maps lies precisely in their ability to 'do work', to create and transform places according to the wishes of those who make them, by centralising and incorporating certain features and disclosing or side-lining others. Thus, they follow tactical considerations and serve strategic interests, which is a mode of practice that is imbedded in our profession as architects, though seldom confronted and discussed.

This studio was conducted in partnership with the ZK/U, the Centre for Art and Urbanistics in Berlin, which was not only the project site, but also had a vested interest in seeing student perspectives and ideas in relation to the future of ZK/U. The studio therefore ran in parallel to the ZK/U "Fact-Finding Committee (*Untersuchungsausschuss*) #02: Heterotopic Places" which was conducted by Martin Conrads. This activity is part of a series of investigations of timely issues by Berlin's urban society that focus on matters of public interest. For ZK/U, such reports serve to link discourse at local level to global practices and perspectives shared by visiting international artists-in-residence. In this context, the ZK/U was involved in familiarizing the students with the case and Martin Conrads engaged with students in both the midterm and final evaluations.

The studio began by exploring what cultural spaces and civil movements stand for as a concept. Based on existing examples, we discussed the roles these spaces play directly in the neighbourhoods in which they are located, in the city, regionally and internationally. From there, we investigated the use of mapping as a tool for building (scientific, cultural, artistic, etc.) discourse, specifically by civil movements and cultural institutions. To get a sense for the topic and the importance of cultural institutions for urban transformation, we went on an excursion to Brno in the Czech Republic, where students got to meet and talk to activists, artists, and other stakeholders in new municipalist movements in the city. Students were given exercises to conduct mapping on the ground and to make initial hands-on experiences with different mapping topics and techniques – both with regard to data acquisition as well as information display and communication. Based on this introductory period, we delved into exploring



Excursion in Brno, Czech Republic
Foto: Andreas Brück

Martin Conrads is an author and cultural producer who lives in Berlin and was tasked with conducting the UA #02, between November 2018 and February 2019. Results were published under the title "FEBRUARY 29 2052" – edited by Martin Conrads.

the potential of mapping for practitioners in the field of urban planning and design. By envisioning future scenarios for ZK/U, we asked: How can urban planners and designers capitalise on mapping to forge a different, new mode of practice that is more inclusive – where action strategies, alliances and visions are created and set collaboratively and collectively?

After a period of mapping ZK/U and the surrounding areas in Moabit, Berlin, students were tasked with developing proposals that reflect their visions for ZK/U until 2050, in phases and by involving particular segments of society that they identified from their mapping. In light of readings that we discussed in class, the exploration of various mapping tools as well as their site analysis, we requested that they think of ways of incorporating people into the place-making of ZK/U, to consider changing aspirations over time, and to suggest ways to deal with resource scarcity. The ideas presented by our ten students varied in some ways and intersected in others, with some of them presenting intriguing visions that were taken up and incorporated into the report on ZK/U's Fact-Finding Committee (UA) #02: Heterotopic Places. In this section, we present what we felt were the best four proposals:

The first project entitled "A Cohesive Flow" by Eicy Babb assumed that climate change will cause the nearby 'Westhafen' port to cease operations. In her proposal, she encouraged ZK/U to think of ways to advance initiatives to take over the management of the cleared port area, rail lines, and the canal. Her concept focused on incorporating citizens interested in urban farming and education into the building of the future of the ZK/U, and to boost its recreational and commercial activities.

The second project entitled "Second Nature" by Ruslana Massarova focused on the issue of digitalisation and how ZK/U could develop into a flexible, interactive site that nurtures new modes of interaction and understanding between the analogue and the digital in the arts and beyond. Her concept focused on rethinking what cyberspace in the lived space can be, arguing that it will reduce limitations and help the materialisation of imaginaries.

The third project entitled "ARTLINK" by Yan Ming took a provocative approach by focusing on the hyper-mobility of new generations of artists and on their ability to be messengers connecting the site regionally and globally. In practical terms, he proposed turning the ZK/U into a flexible working, exhibiting and camping site. His concept focused on incorporating artists and those interested in vehicle customisation. However, it also envisioned new formats for the ZK/U to engage with other parts of Berlin in the form of a mobile cultural centre.

The fourth project shown in this section is entitled "Park Culture" by Lovie Tey, who focused on the issue of open, green spaces and urban farming. In her proposal, she presents possibilities for ZK/U being used as a productive space throughout the different seasons by different age groups, but with particular emphasis on opening it up as a centre for learning, work and leisure for the youth.

This studio was conducted in parallel with a sister-studio at the master's program in urban design at the Technical University of Berlin, where we coordinated our activities with our colleagues Zuzana Tabackova and Angela Million. Students in our studio met with their peers at ZK/U, took part in the excursion to Brno, and presented together at the midterm and final juries to a panel that combined members from the three involved institutions. All in all, we think this was a very productive exercise because it gave students at the DIA as well as TU-Berlin a chance to see how others – with different academic backgrounds, design knowledge, and following different path of higher studies – looked at and handled the task at hand, and to inspire one another. Similarly, we think it was helpful for the students to see their works exhibited to a public audience and discussed outside of academic circles at the Open House of ZK/U, which took place in late February 2019.

MAPPING A FUTURE ZK/U

During the winter semester of 2018/19 – in parallel to and interrelation with the activities of the Fact-Finding Committee #02 – two student groups, one from Technische Universität Berlin (TU Berlin), the other from the Anhalt University of Applied Sciences (HS Anhalt) in Dessau-Roßlau, worked jointly on ideas for the future of the ZK/U:

Radical Mapping as Design for Urban Resilience. A Cultural Centre for the 21st Century

TU Berlin
Faculty VI Planning Building Environment
Department for Urban and Regional Development
Prof. Angela Million, PhD
Zuzana Tabáčková

Tasks given to students of the Technische Universität Berlin (excerpt):
Maps do not just depict reality – they also create it. They reflect and perpetuate power relations and have always been political instruments that influence our understanding of the world. In the contemporary struggle for new solutions to urban issues, maps are being used in various ways and by a variety of actors to drive socio-spatial ecological change towards a more just change. The status quo is thoroughly questioned and alternatives are created by a number of actors also beyond urban design and planning. Mapping is thus not only a tool in design and planning to capture and reflect on local practices, but is itself a means to shape and create spaces and social relationships. In collaboration with the Zentrum für Kunst und Urbanistik (ZK/U) in Berlin, the project explores the potential of mapping as a tool for designing innovative and radical concepts for cultural spaces of the 21st century. Together we will look for answers to the following questions: What potential does mapping have for civil society initiatives in terms of cooperation and transformation towards just neighborhoods? What knowledge can be created through mapping? What role do new (and old) technologies play and how can they be usefully integrated in the approach?

Urban Transformation through Mapping? Envisioning Future Scenarios for ZK/U

Anhalt University of Applied Sciences, Dessau-Roßlau
Department of Architecture, Facility Management and Geoinformation
Dessau Institute of Architecture
Visiting Professor Natasha Aruri, PhD
Visiting Professor Andreas Brück, PhD

Tasks given to students of the Anhalt University of Applied Sciences (excerpt):
In partnership with the Zentrum für Kunst und Urbanistik (ZK/U) in Berlin, the Studio will investigate mapping as a tool used by civil movements, cultural institutions and others, and explore its potential for practitioners within the field of urban planning and design. Envisioning future scenarios for ZK/U, we will ask: How can urban planners and designers capitalise on mapping to forge a different, new mode of practice that is more inclusive – where action strategies, alliances and visions are created and set collaboratively and collectively? Within the context established through mappings, in combination with your own vision – as well as contemporary trends and developments – we inquire: What is your unique proposition for the future ZK/U? What is your idea for a social and cultural centre of the 21st century? What are its spaces for cultural and social production? Which social and material spaces are part of the future ZK/U? Who are the visitors and who is the audience – how do they interact with ZK/U? In the future, how does ZK/U relate to its immediate and global context? And how does it function?

Three of the students' projects are depicted on the following pages:

Playground for Adults by Ruslana Massarova (HS Anhalt)
(Excerpt, project status January 2019)

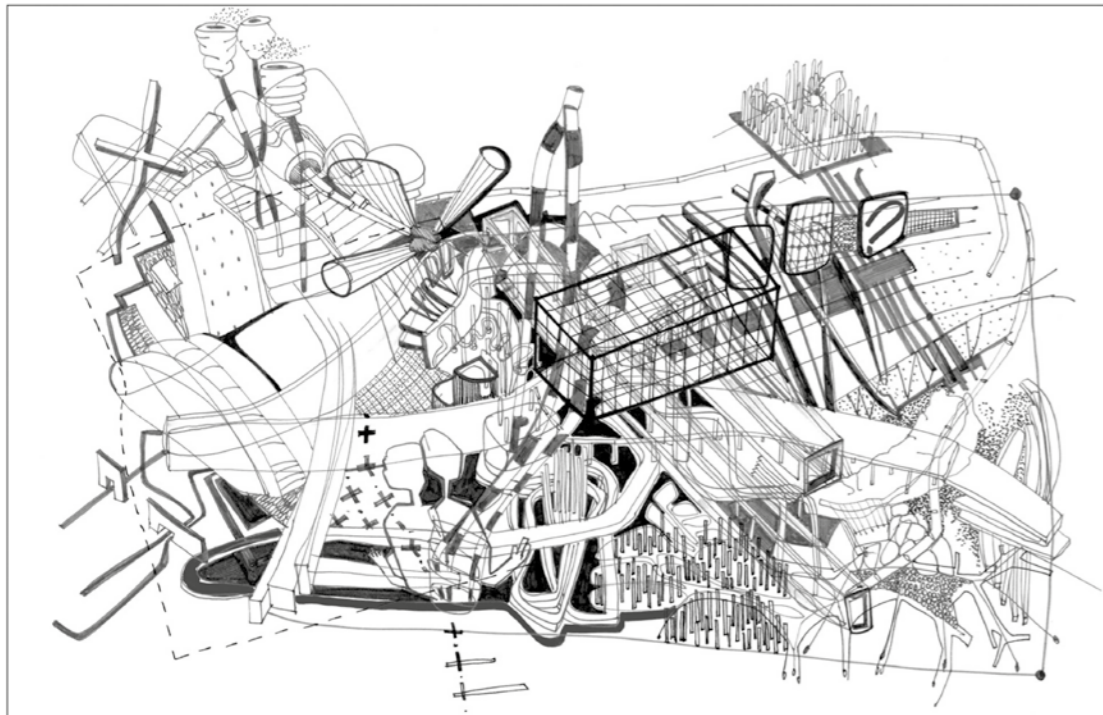

© Ruslana Massarova

Arbeitsergebnisse des Studios wurden publiziert in:
Conrads, Martin (Hg.): February 29, 2052.
Fact Finding Committee #2, Zentrum für Kunst und Urbanistik (ZK/U), Berlin 2019.

Kunstopia by Mitchell de Sousa, Federico Alfaro and Bryan Galindo Cárdena (TU Berlin)
(Excerpt, project status February 2019)

Kunstopia

formed into

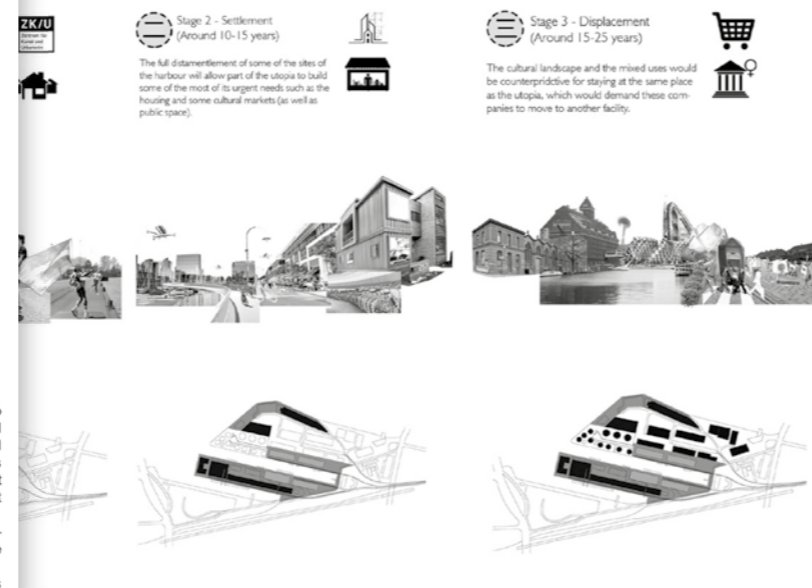

© Mitchell de Sousa, Federico Alfaro and Bryan Galindo Cárdena

A SPASMODIC I.n.t.e.r.v.e.n.t.i.o.n by Eicy Babb (HS Anhalt)
(Excerpt, project status February 2018)

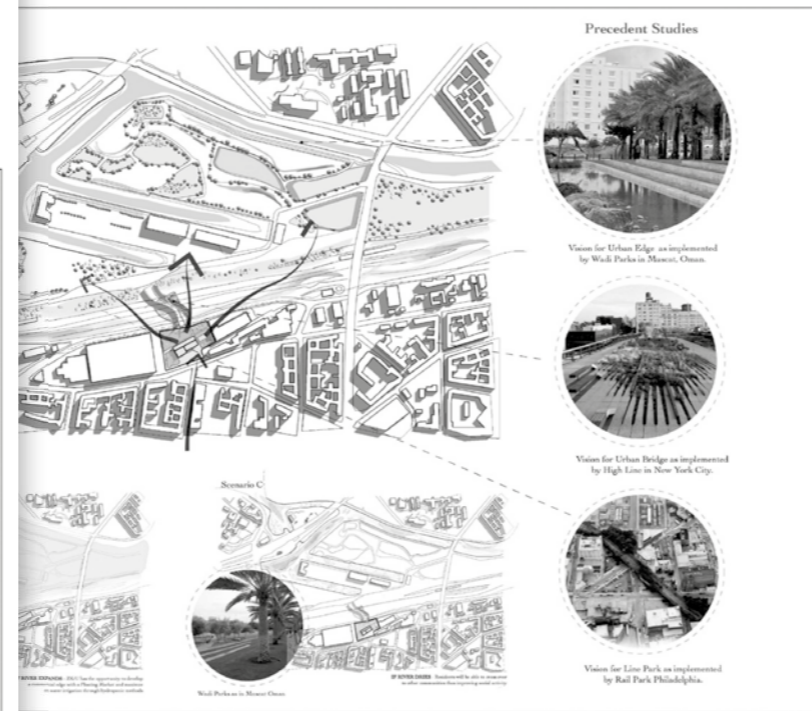

© Eicy Babb

ZK/U/SP/NÖ 2052

Zentrum für Kunst / Urbanistik /
Soziale Praxis / Nachhaltige
Ökonomien

Center for Art / Urbanistics /
Social Practices / Sustainable
Economies

The participants of a workshop held on
February 16, 2019 at ZK/U recommend the
following considerations for ZK/U for
the years to come until 2052 (and beyond):

1. Become a place focused on the questions and challenges resulting from climate change.
2. Develop a carbon-neutral footprint in the short term and become a carbon-negative institution in the medium term.
3. Sustain basic services such as the distribution and supply of fresh water through cultural practice.
4. Become a place that reacts to and shelters from extreme climatic conditions; offer free access to cooling and heating.
5. Build partnerships to expand habitable microclimates.
6. Support the retrofitting of the nearby power station (Heizkraftwerk Moabit), which is partly coal-fired, in favour of biomass combustion only – even before 2030.
7. Establish a planning office for a possible expansion of ZK/U into the Westhafen area.
8. Establish public participatory procedures to define space usage requirements regarding the expansion of ZK/U into the Westhafen area.
9. Develop an autonomous neighbourhood in the Westhafen area.
10. Form part of a new Berlin district "Westhafen" by renegotiating the delineation of public / private.
11. Offer a forum to formulate political claims resulting from causes and effects of climate change.
12. Become a catalyst for the discussion and production of social/cultural change in the new climate.
13. Build alliances with other life forms to circumvent legal regulations.
14. Plant and protect one or more trees on the roof of ZK/U so that the lifespan of the tree(s) legally protects the existence of ZK/U beyond 2052.
15. Find experts that help ZK/U to build a micro-climate in order to become a legal nature reserve.
16. From 2052 onward ZK/U nature reserve should begin to expand farther across Berlin into Brandenburg.
17. Host a library and research centre for the emerging knowledges of and about climate change.
18. Initiate site-specific investigations to align local interests with universal questions of climate change.
19. Offer space to productively negotiate local antagonistic interests in view of climate change.
20. Represent diversity within ZK/U's structure in regards to race, gender and class.

This page is part of the publication "February 29, 2052", edited by Martin Conrads for the "Fact-Finding Committee #02" at Zentrum für Kunst und Urbanistik (ZK/U) in Berlin and published by ZK/U Press in February 2019.

It contains 20 considerations for ZK/U resulting from a workshop ("Participation Procedures for the Expansion 3.0 of the ZK/U 2052") which took place on February 16, 2019, at ZK/U. The workshop was conceived and directed by Robert Preusse and Stefanie Rau. The considerations were put into writing by Robert Preusse and Stefanie Rau and edited together with Martin Conrads.

Participants in the workshop were Martin Conrads, Beatris Dikker, Philip Horst, Lucas Sere Peltzer, Sebastian Podesta, Robert Preusse, Stefanie Rau, Vera C Ritter, Bärbel Rothhaar, Gustavo Sanromán, Lotta Schäfer and Magdalena Taube.

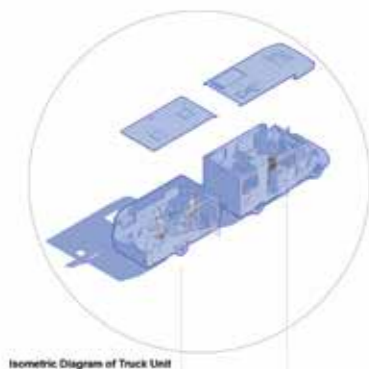

Isometric Diagram of Truck Unit

WORKING UNIT LIVING UNIT



MOBILITY

As more artists start to join the residency program in ZK/U. An alternative to hold an uprising number of artists. Using trucks as a movable living unit can reduce the great demand of the residency in ZK/U. Other artists can come here by their own trucks and stay here as being in a camping site. This increase the mobility of the artists and can interact with other institution in an effective way.

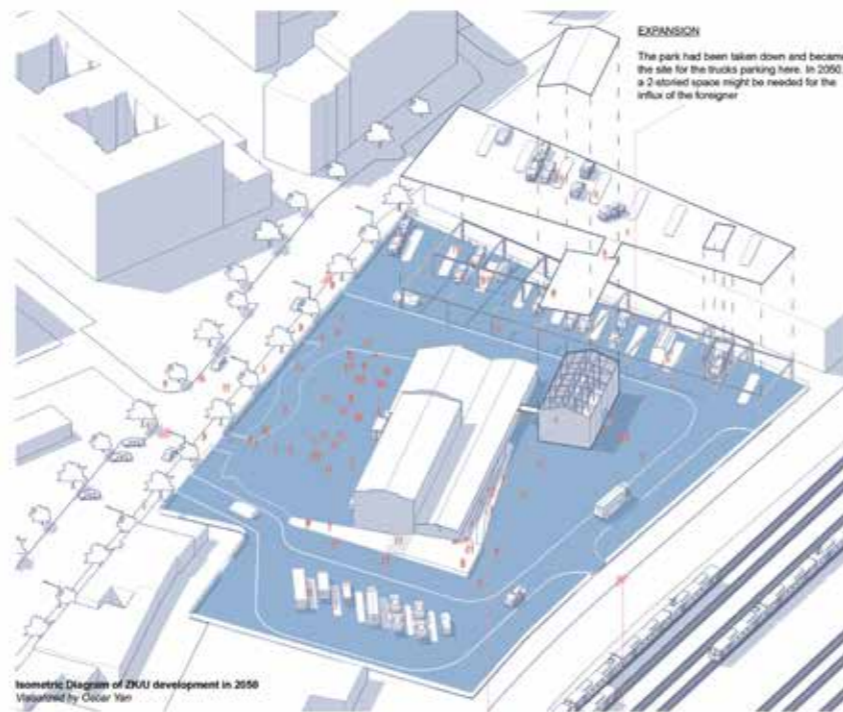

Isometric Diagram of ZK/U development in 2050
Visualized by Oscar Yan

EXPANSION

The park had been taken down and became the site for the trucks parking here. In 2050, a 2 storied space might be needed for the influx of the foreigner.

CO-WORKING

As more artists start to join the residency program in ZK/U. They will live in their own trucks most of the time and they can enjoy the co-working space in this temporary building where connect to the original main building as well. Also, living support facilities can be found inside, such as shared-kitchen, bathrooms, common space.

ACCESSIBILITY

Connecting the vehicle road in the back alley and increase the accessibility to the ZK/U. It makes the route to other places more diverse.

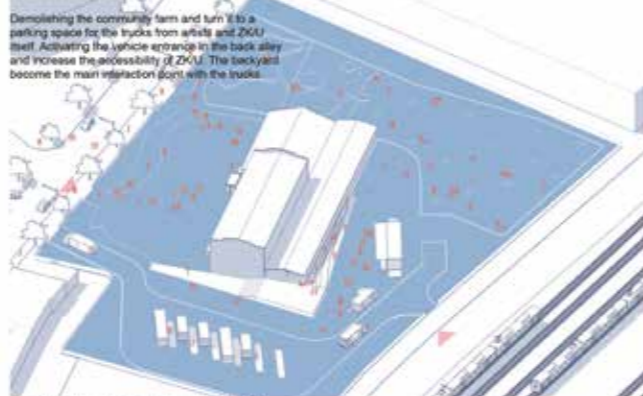

Isometric Diagram Showing Scenario in 2019
Visualized by Oscar Yan

SCENARIO IN 2035

The influx of the artists makes the expansion of the parking slot and keep park in the front part yet. A temporary building provides living support for the residency such as, co-working, kitchen etc.

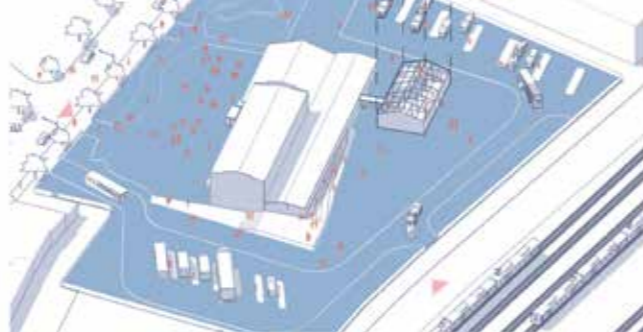

Mapping Analysis
Visualized by Oscar Yan

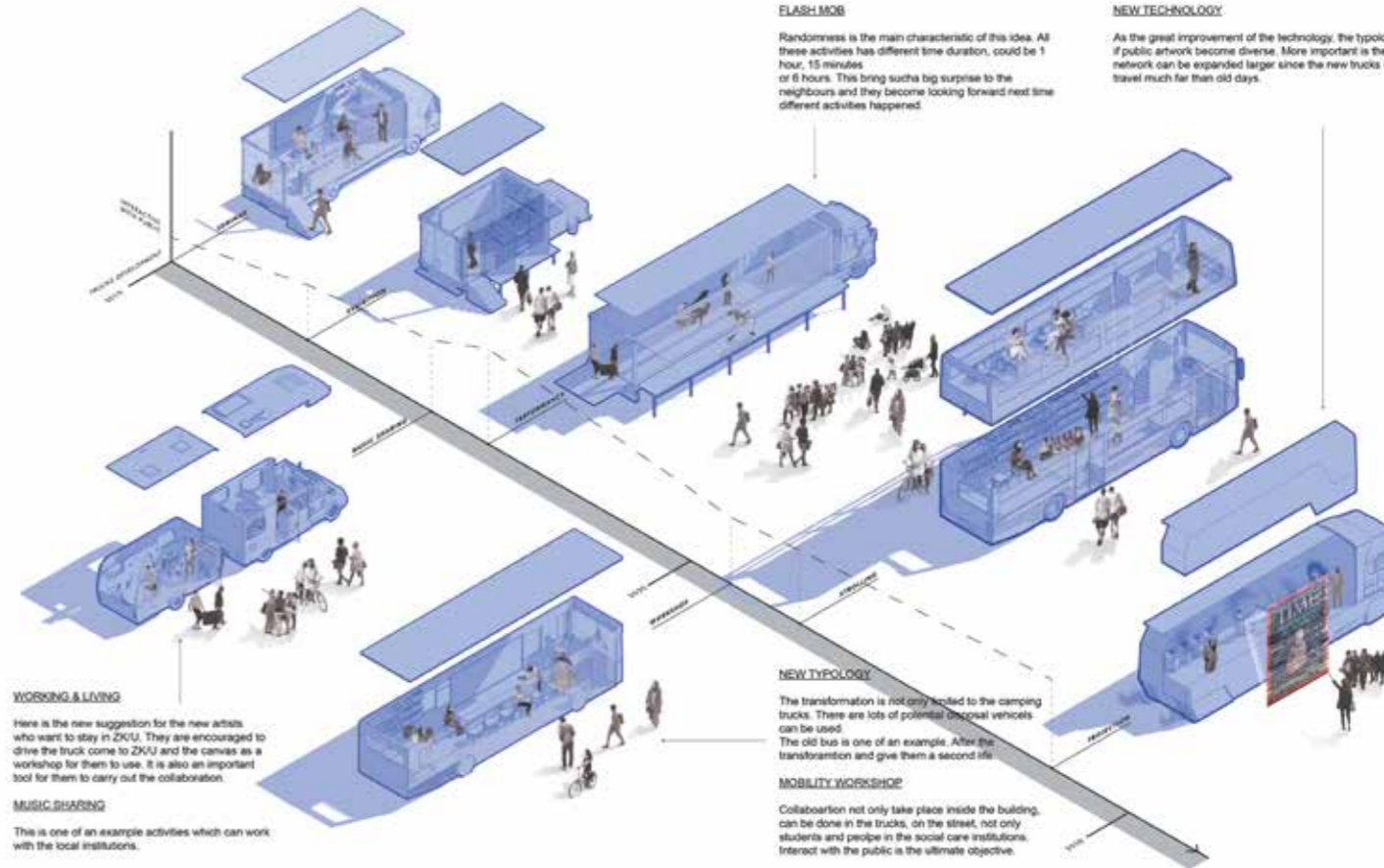

WORKING & LIVING

Here is the new suggestion for the new artists who want to stay in ZK/U. They are encouraged to drive the truck come to ZK/U and the canvas as a workshop for them to use. It is also an important tool for them to carry out the collaboration.

MUSIC SHARING

This is one of an example activities which can work with the local institutions.

FLASH MOB

Randomness is the main characteristic of this idea. All these activities has different time duration, could be 1 hour, 15 minutes or 8 hours. This bring such a big surprise to the neighbours and they become looking forward next time different activities happened.

NEW TECHNOLOGY

As the great improvement of the technology, the typology of public artwork become diverse. More important is the network can be expanded larger since the new trucks can travel much far than old days.

NEW TYPOLOGY

The transformation is not only limited to the camping trucks. There are lots of potential disposal vehicles can be used. The old bus is one of an example. After the transformation and give them a second life.

MOBILITY WORKSHOP

Collaboration not only take place inside the building, can be done in the trucks, on the street, not only students and people in the social care institutions. Interact with the public in the ultimate objective.

Development and transformation of the truck
Visualized by Oscar Yan



BEGIN 2019

From the very beginning, the trucks start with the social institution and school nearby the community.

AROUND 2025

After few years, some initial relationship should be established with those institutions and diverse public art would be carried out by different kind of trucks.



AROUND 2040

Since the network had been establish for more than a decade. Artists keep exploring with their trucks and typology of the public art and collaboration become mature. Trucks, they are not limited in urban anymore.



2050

After these years, social awareness and community identity had been read. I imagine in 2050, pollution problem become one of the hottest topic in that time. Artists can travel a longer way, not only Europe and might be expand the network to other continents.



CENTRE FOR ARTS AND URBANISTIC ARTLINK

Oscar Yan Ming
DIA Master Architecture Studio WS 2018/19
Supervisors: Dr. Natasha Aruri,
Dr. Andreas Brück

ArtLink is a collaborative vision where ZK/U and artists establish their own networks in the neighbourhood. It is time to transform to become a mobile cultural institution. ArtLink lets art connect experiences and build social awareness and community identity. Vehicles as mediums to connect can be transformed to include other functions such as seminars, exhibitions, and staging. They can be used to reach out to and inform people about the work of ZK/U who can also take an active role in exploring and making interventions beyond the site. They can also become the studios of artists-in-residence.

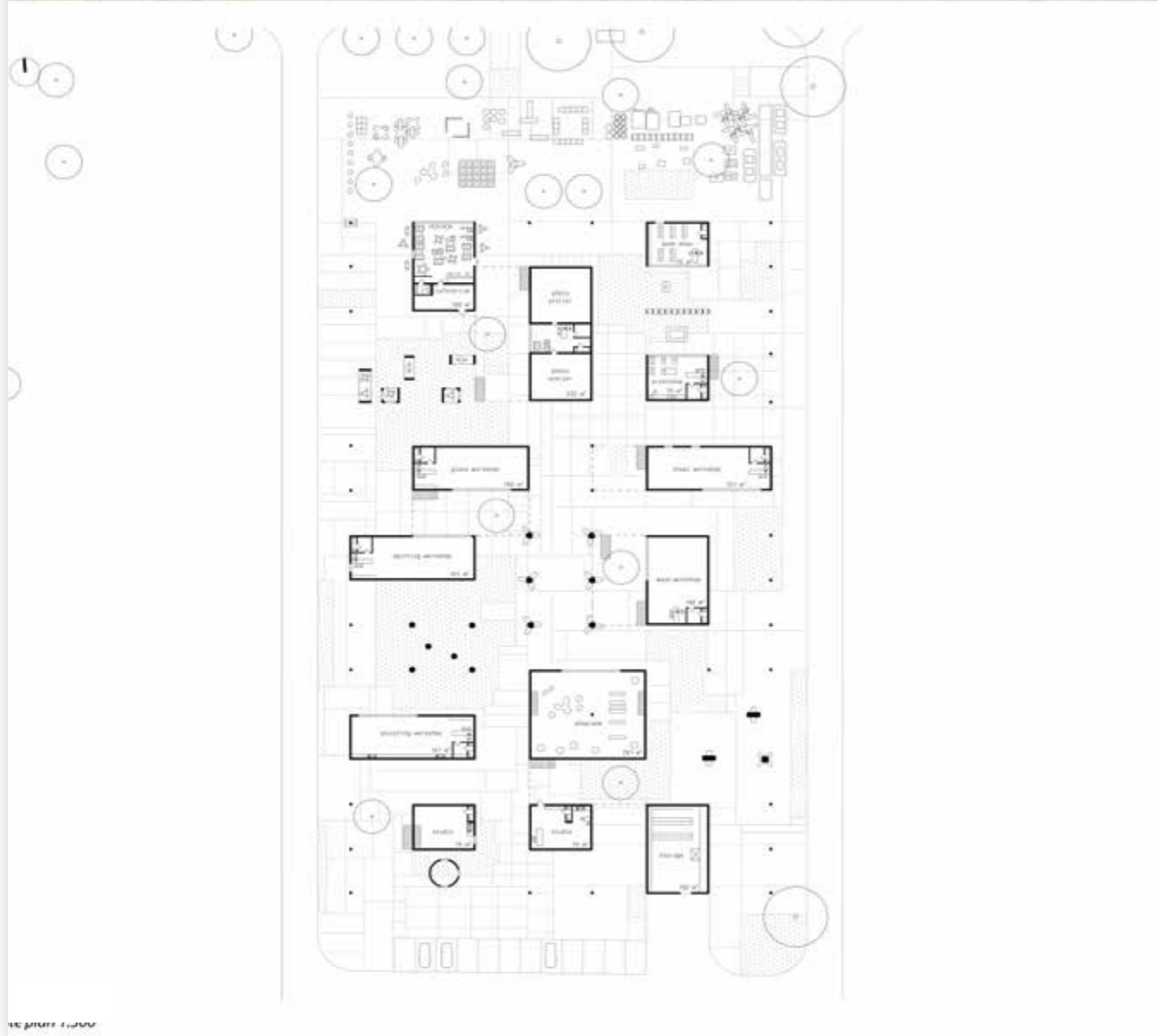

Site plan

THE ATELIER

Oksana Chebina

DIA Master Architecture Studio WS 2018/19

Supervisor: Johanna Meyer-Grohbrügge

Library of precast concrete elements

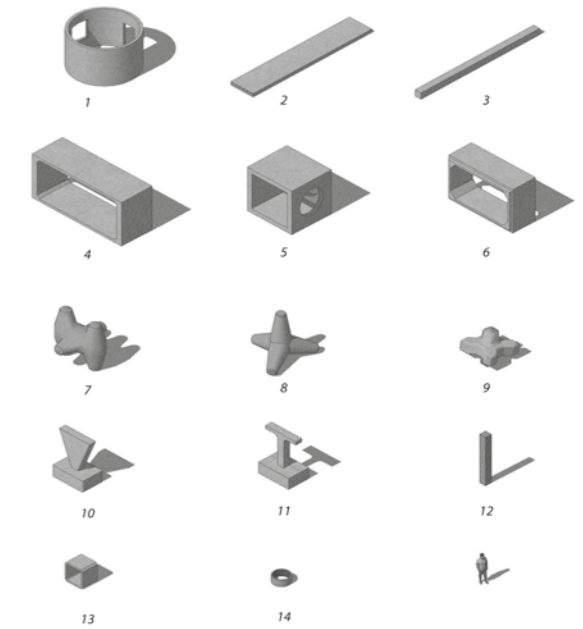
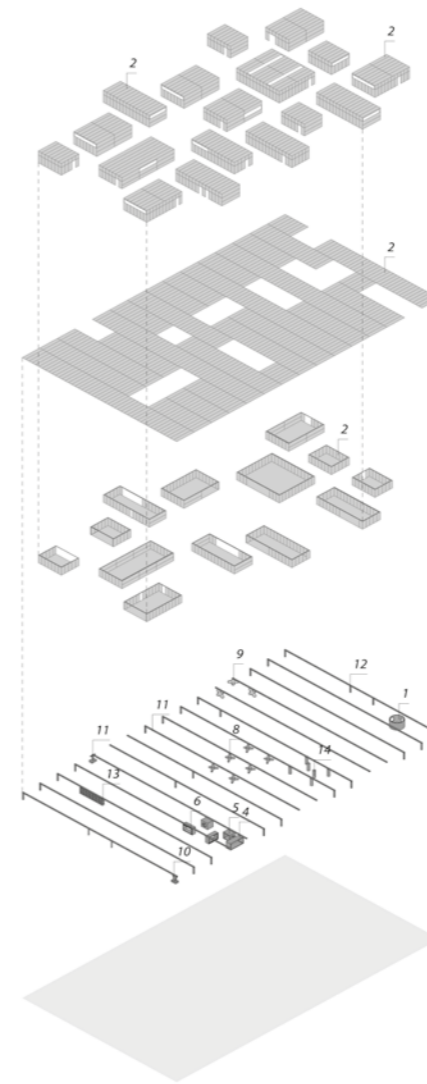

Usage of elements



1. Storm drain junction box

3. Beams and 12. Columns

4. Culvert

8. Breakwaters

13. Well Rings

14. Well Rings



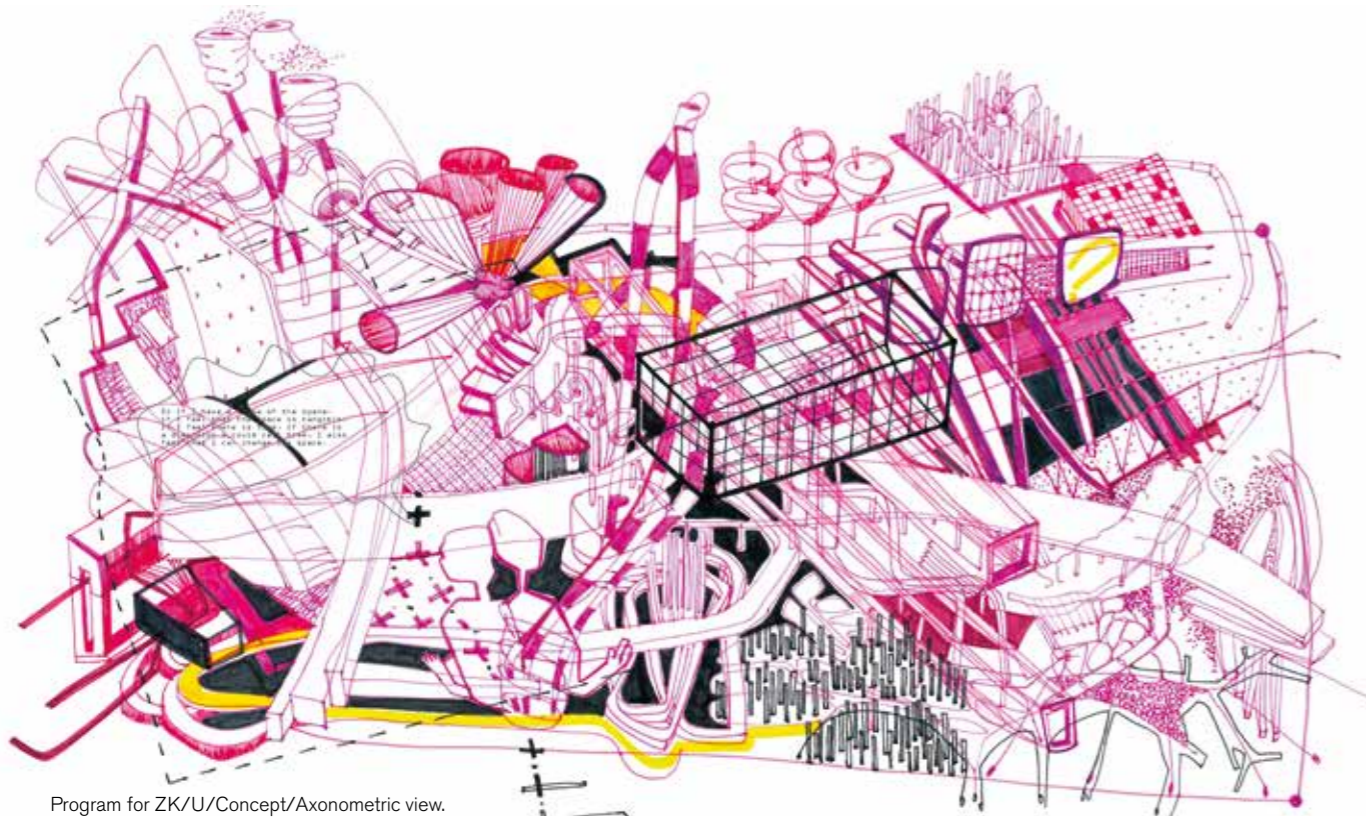

Program for ZK/U/Concept/Axonometric view.
Foto: Ruslana Massarova

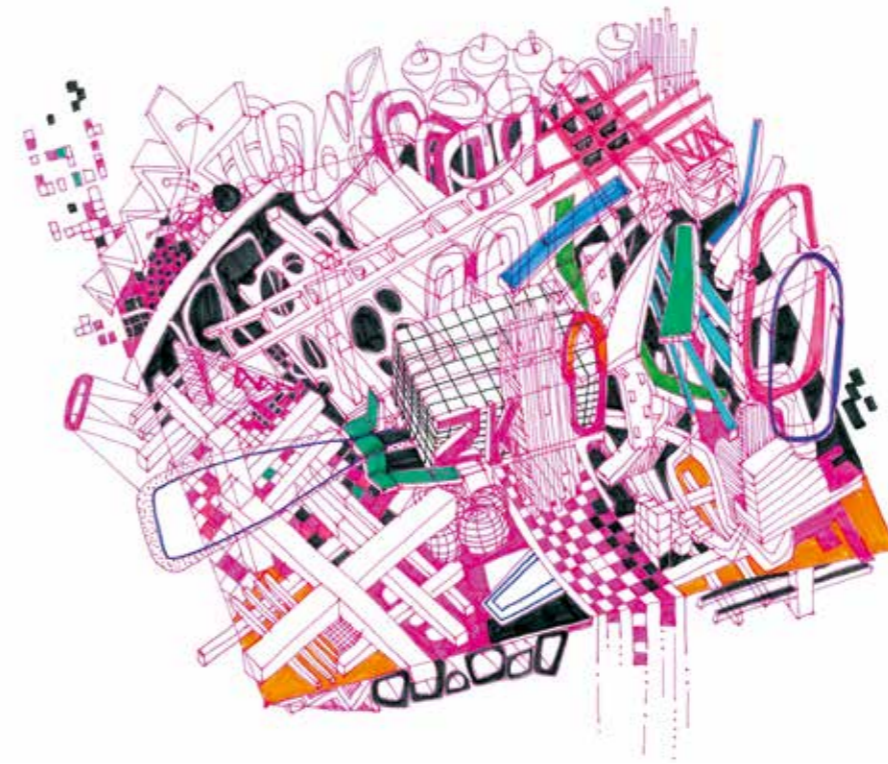

SECOND NATURE
*PLAYGROUND FOR ADULTS/
ZK/U AS A REAL PLACE INTO VIRTUAL*

Ruslana Massarova
DIA Master Architecture Studio WS 2018/19
Supervisors: Dr. Natasha Aruri,
Dr. Andreas Brück

What are you next? Considering trends of implementation of the digital environment in our reality, forgetting nature and our primary, this space will make it possible to understand an entity of the person as the nature and interrelation. It will also make it possible to gain experience by mixing the lived and analogue nature. Currently, this digital exists as a component, but in future, it can be applied throughout the city structure. In 2050? Verbally created virtual spaces are not physically seen, they are spaces in the mind, of imagination, of uncertainty. However, despite feeling invisible at first, our subjects testify that once they login and enter, say a chatroom, they feel that they are already in a space. The feeling of being in a space is so real, although the shape of the space is vague. 'Hybrid' spaces, focused on discussing the future of our environment, will function as a generator of local identity (and trust).



Basic Model/ Component 2050.
Foto: Ruslana Massarova

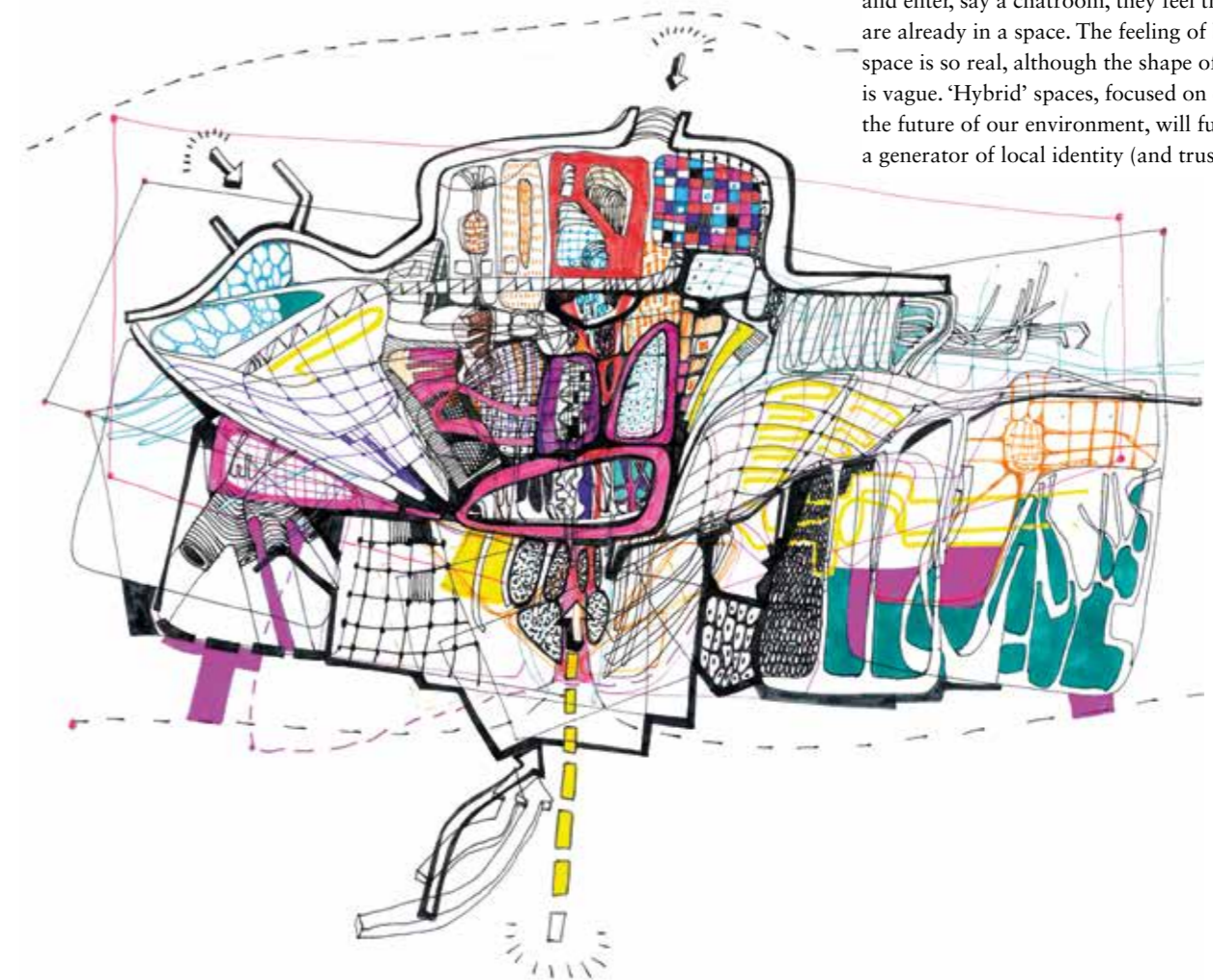

INTRO

Throughout the few decades, technologies had been tremendously growing better, allowing future long term space exploration more accessible in a hostile environment. Mars Mission which was one of the convincing proposal over the last century for humans space exploration due to the cogent evidences of elements to support life. Thus, a design solution is proposed to optimize a living habitat [MARSHAUS] by the aid of robotics constructions on Earth and Mars. The focus of this research will be developing the possibilities of 3d printing with robotic arm by injecting biomimicry litation which will be beneficial into 2 phases of architecture process in a modular form : [Phase01-On Earth] developing lightweight architectural materials to [Phase2-On Mars] ISRU<in-situ resources utilization> extreme environment construction . Both phases will be synchronize and equally crucial as it will be advantageous with one another . In addition, the aim of modular system design are to ready for future robotic mass production when the system are fully developed.

SITE

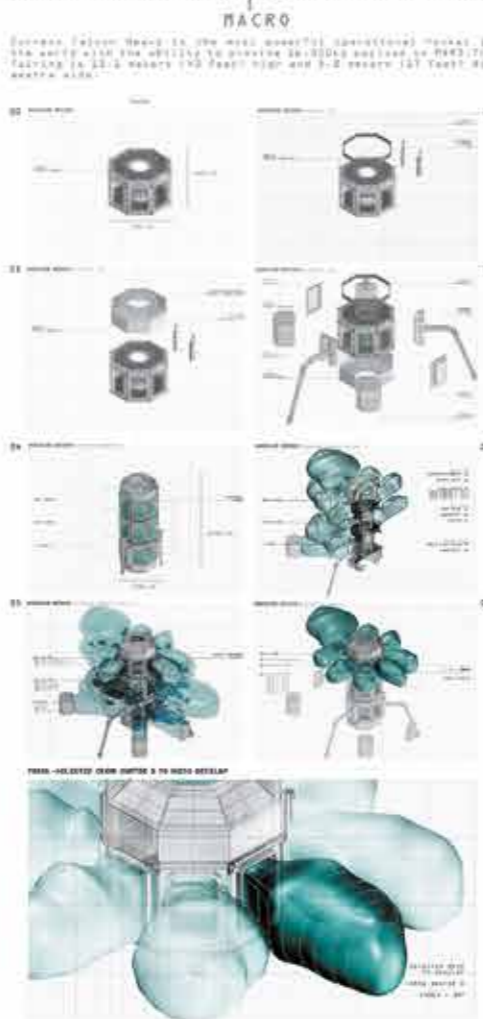

01 HABITAT - ECV DESIGN

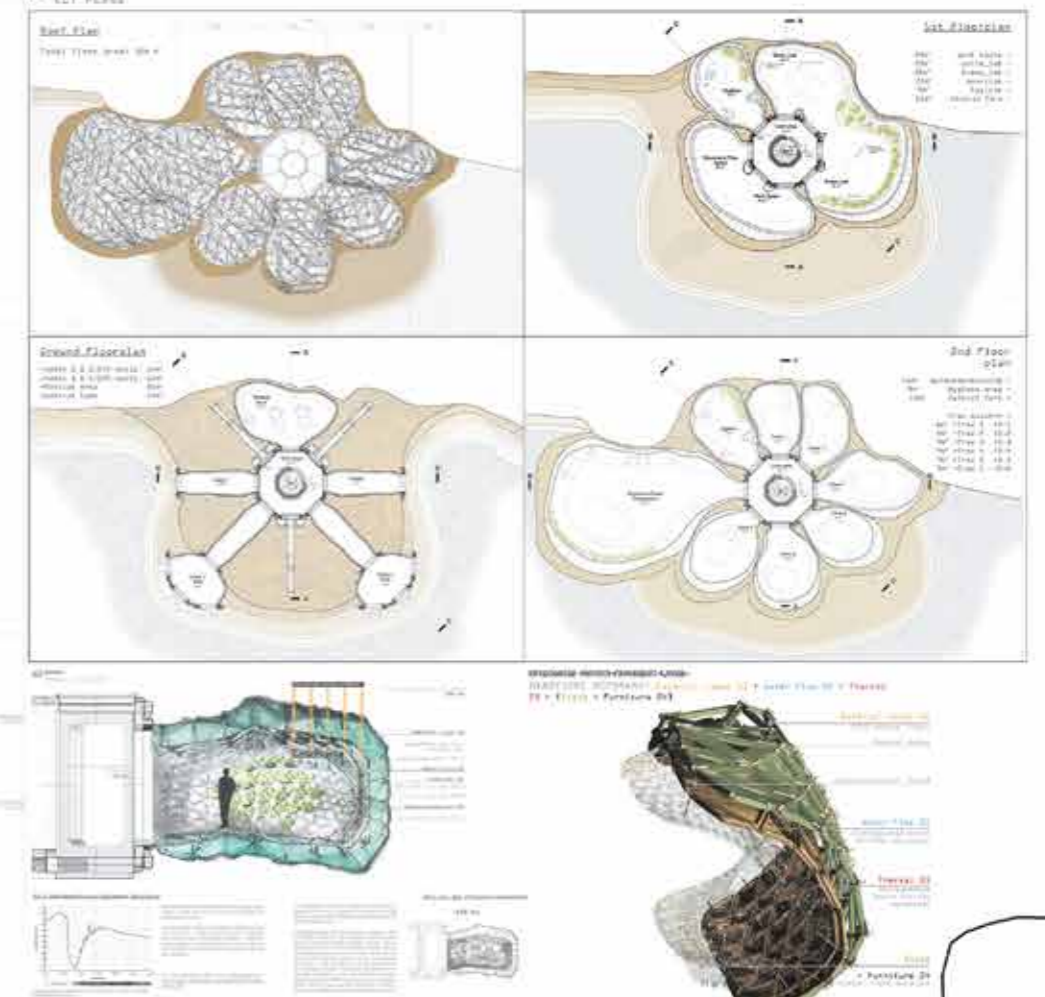

Side Elevation

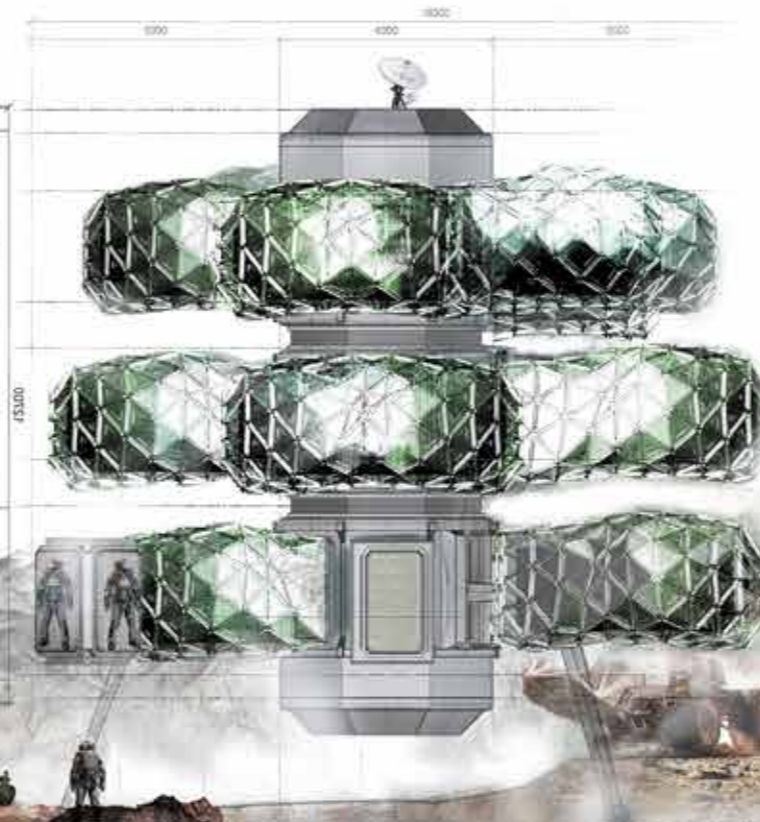

Front Elevation

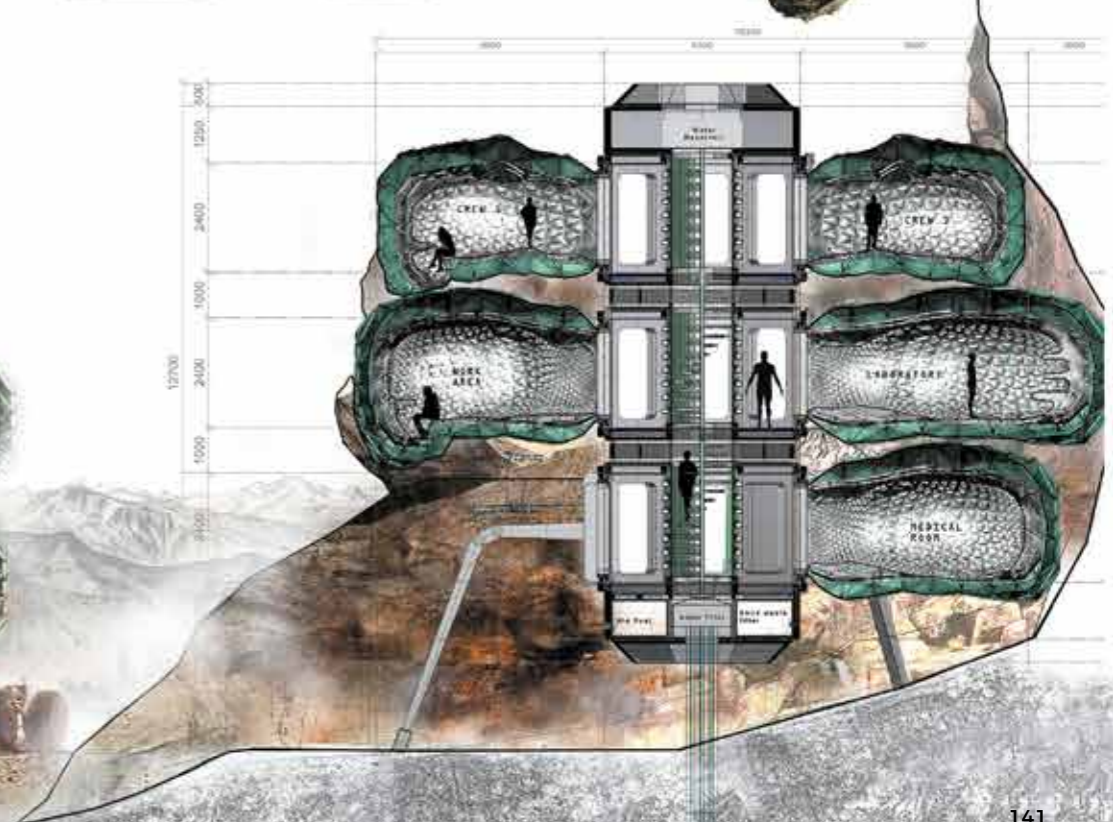

Side Elevation

WUNDERLAND
WISDOM PARLOUR

Soh You Shing
DIA Master Architecture Studio SS 2018
Supervisor: Eric Helter

Section A-A'
Scale 1:100

WISDOM PARLOUR

Alice met Absolem, the blue caterpillar when she was shrunk to a tiny size. Absolem usually talks to Alice in short sentence or difficult questions. He also gives instructions to Alice when she needed help.

As Tony Cragg is also a lecturer, the first pavilion, Wisdom Parlour is proposed to allow Tony Cragg to carry out his lecture or workshop in the park. This would be a great opportunity for Tony Cragg to bring his students to visit his Sculpture Park and gives lecture at the same time. The scattered seats which is located inside and outside the pavilion allow users to have a more relaxing atmosphere to enjoy their discussion in nature. Users can also spend their time seating, sketching and enjoy the beauty of the Sculpture Park.



Floor Plan
Scale 1:150



Section C-C'
Scale 1:100

COURT OF HEARTS

The last person Alice met in Wonderland is the Queen of Hearts. She is a foul-tempered monarch who is quick to give death sentences at the slightest offense. The Queen of Hearts is always finding new ways to entertain herself. Entertainment plays a huge role in her life.

As the Sculpture Park held some small music concerts once in a while, the third pavilion proposed is a platform for people to carry out small performances. The pavilion comprises of three individual small pavilions. Different types of small intimate performances will be carried out in these pavilions, such as silent poetry, singing, dancing and etc. Visitors will have the chance to enjoy some small entertainment under the beautiful atmosphere in the Sculpture Park. This pavilion will bring out lively part of the Sculpture Park which the visitors will truly enjoy it.



Floor Plan
Scale 1:150

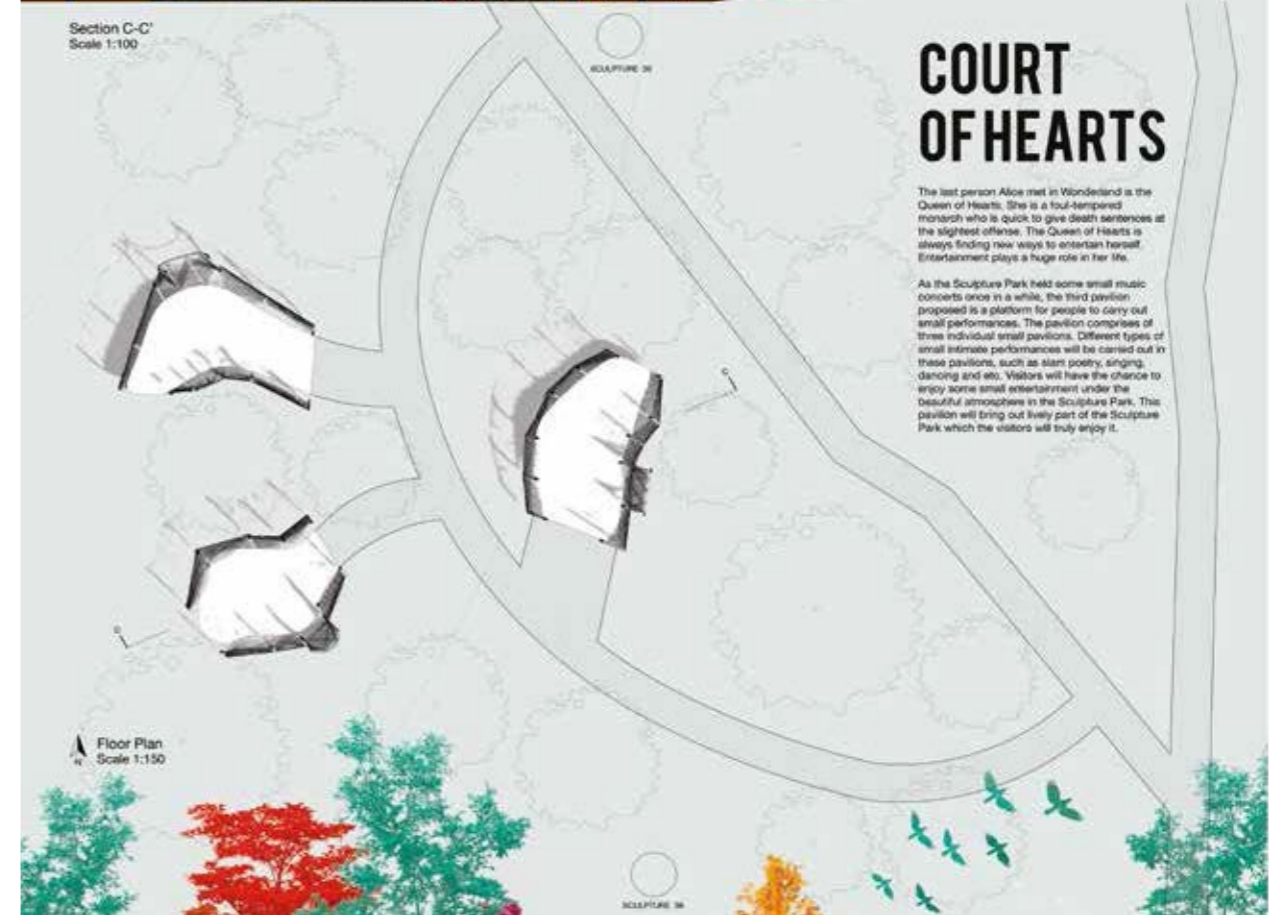

MORE THAN MEETS THE EYE INHABITING THE IN-BETWEEN

Melissa Wyeng-Tse Kong
DIA Master Thesis SS 2018
Supervisor: Ivan Kucina
Second Advisor: Johanna Meyer-Grohbrügge

Inhabiting the in-between is essentially a project about expressing a freedom of space within the city that we inhabit and the space that we live in. In the context of the 'In-Between', the project focuses on representing a realm of living possibilities yet to be discovered as a way of exploring the extent to which spaces can be inhabited in our daily life. The case study for this research draws on the Japanese philosophy of 'Ma' in understanding the origin and application of void as a space for potential occurrences. The meaning of 'Ma' can be visually identified from its symbol which combines a door and a sun. Together, these two characters depict a door through whose crevice the sunlight seeps in. Hence, 'Ma' is used to define an interval that gives shape to the whole, it emphasizes the pause in time, the emptiness in space that creates harmony and unity between two or more things that are brought into a relationship. The focus of this project is on re-imagining spaces in the contemporary city, on discovering urban spaces within the structure of an evolving city. This also appears as a re-evaluation of our everyday lives, as recognizing the In-Between would reveal attributes of urban subconsciousness that would reach beyond its own specific parameters. Because ultimately, the In-Between space is where living extends. I chose Berlin as an overall context to study because people who inhabit Berlin today are trying to erase the memory instead of

preserving it. In this way, Berlin is setting an example by effectively filling the void in order to lose the representation it carries. Besides, the flow of events throughout its timeline provides glimpses of how this city is growing on an unplanned urban landscape formed by vast tracts of empty spaces. To me, this is a way of reading into the formation of voids through natural processes; how emptiness morphs into what non-emptiness is formed afterwards. The unit of study focuses on the daily events of Berlin and the resulting space which opened up within the city. These events are recorded as a series of photographic observation of how the city is used by its inhabitants on a daily basis and is done so as a means of articulating the In-Between. These fragments of information are layered and composed together as a method of articulating this realm, ultimately to create an identity of the In-Between as a space. Hence, this thesis is an explanatory case through the exploration of collective photographic records and mapping information. At the end of this research, I hope to express the In-Between realms as a series of spatial possibilities, to show that these spaces are integral to living and an intrinsic part of the life of a city. Building on this, I hope that the method of mapping the relationship between physical and intangible elements and using them as experiments in articulating spaces, this project could also serve to present ways of reimagining architecture.





KREMATORIUM
*ARCHITEKTUR DER
 BESTATTUNGSKULTUR*

Janet Landwehr
 Master Architektur Thesis SS 2019
 Supervisors: Prof. Dr. Matthias Höhne,
 Prof. Ralf Niebergall

Seit deren Etablierung verlangt die Bauaufgabe Krematorium den Spagat zwischen der bestimmenden technischen Seite und dem Anspruch an architektonische Monumentalität. Beim vorliegenden Entwurf soll dieser Spagat gelingen und die Natur in das Konzept miteinbezogen werden. Die technischen und die feierlichen Räume werden auf einem Geschoss angeordnet. Getrennt werden sie durch einen Innenhof, in dem sich ein Kolumbarium befindet. Die Monumentalität wird durch die Raumhöhe sowie den Säulengang am Eingang erzeugt. Abgerundet wird der Entwurf durch eine durchdachte Landschaftsgestaltung und die Verbindung zur Natur.

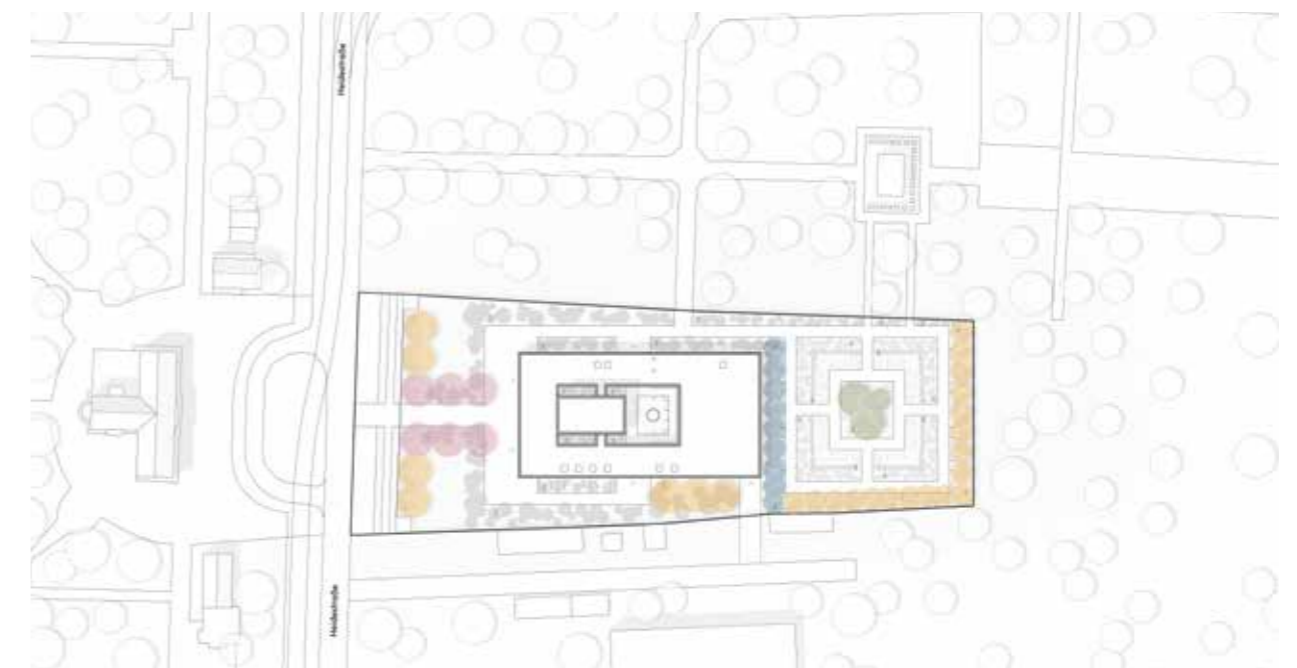
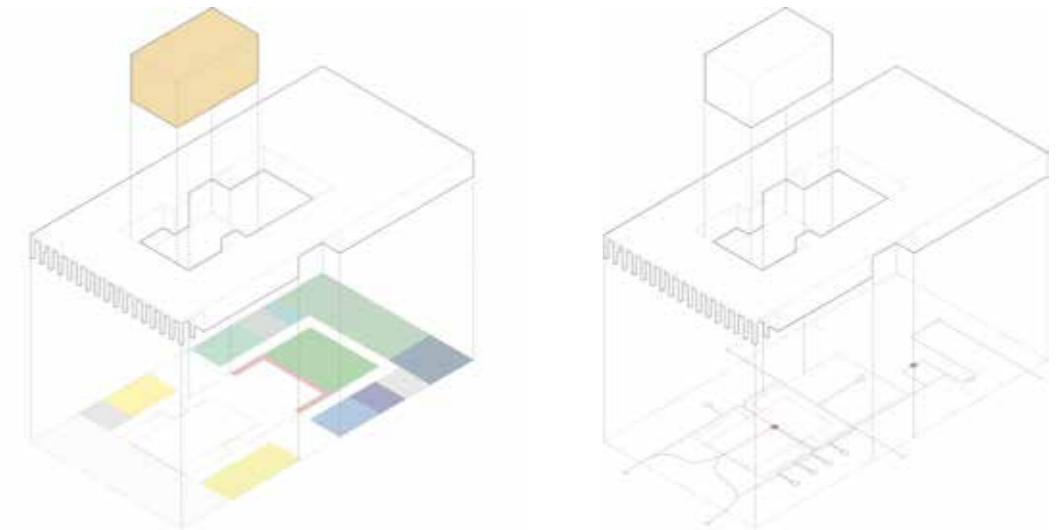
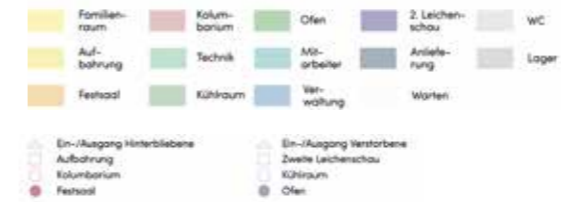

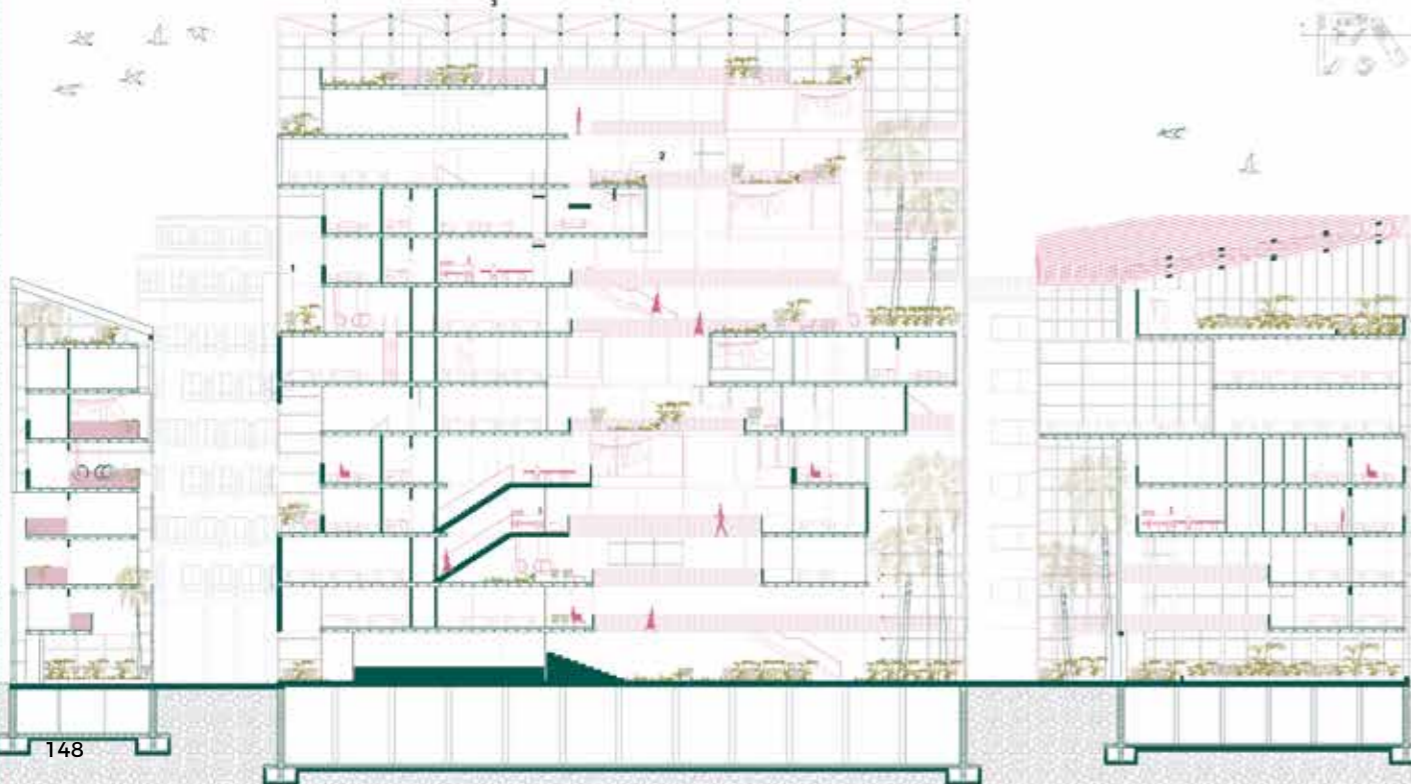
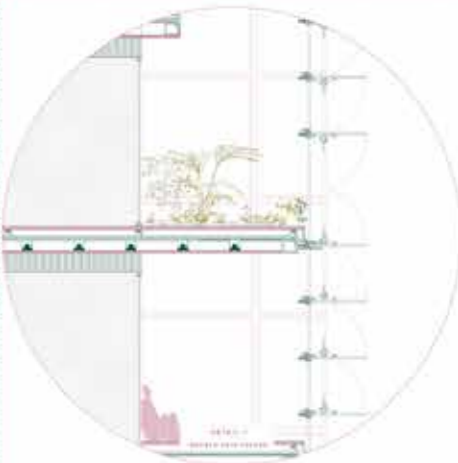

KONTORHAUS
 OF THE 21ST CENTURY

Zhou You
 Master Architektur 2018 Studio
 Supervisor: Prof. Ralf Niebergall

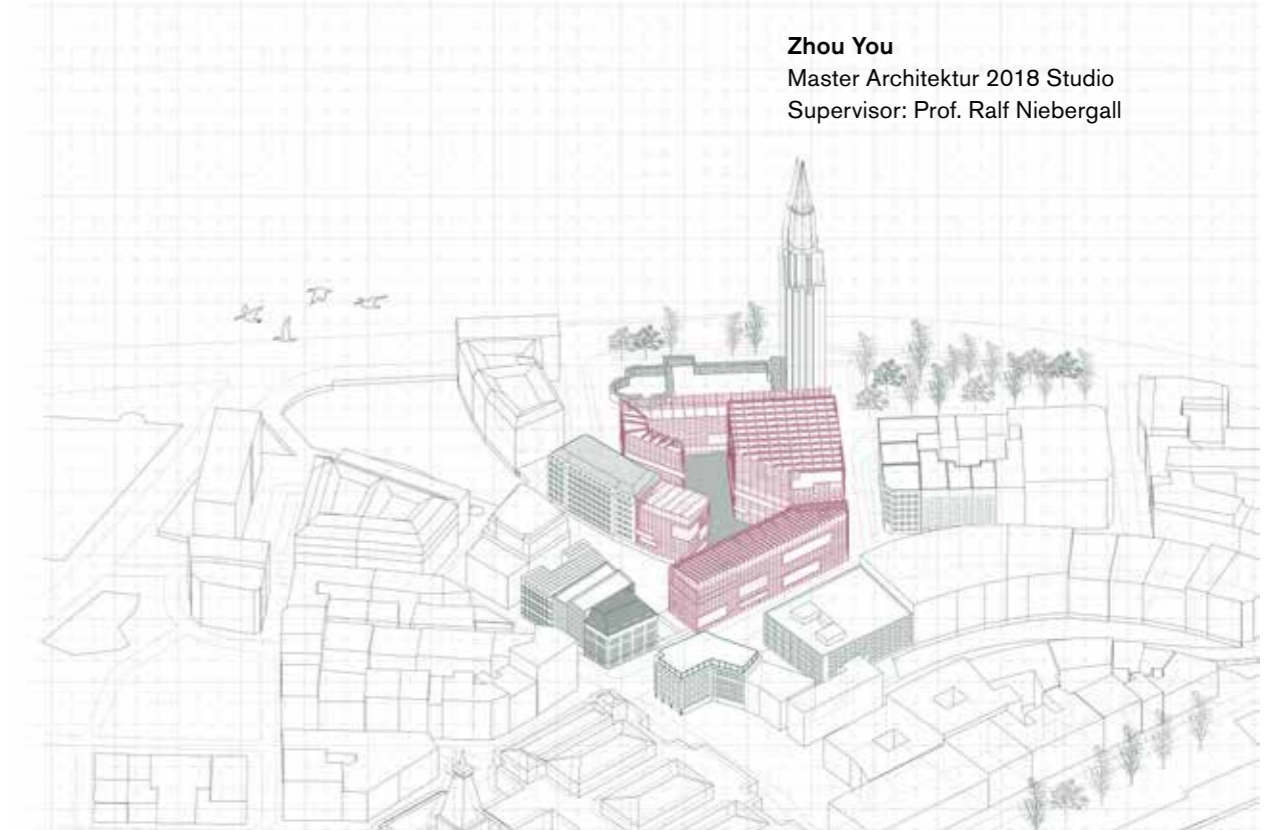

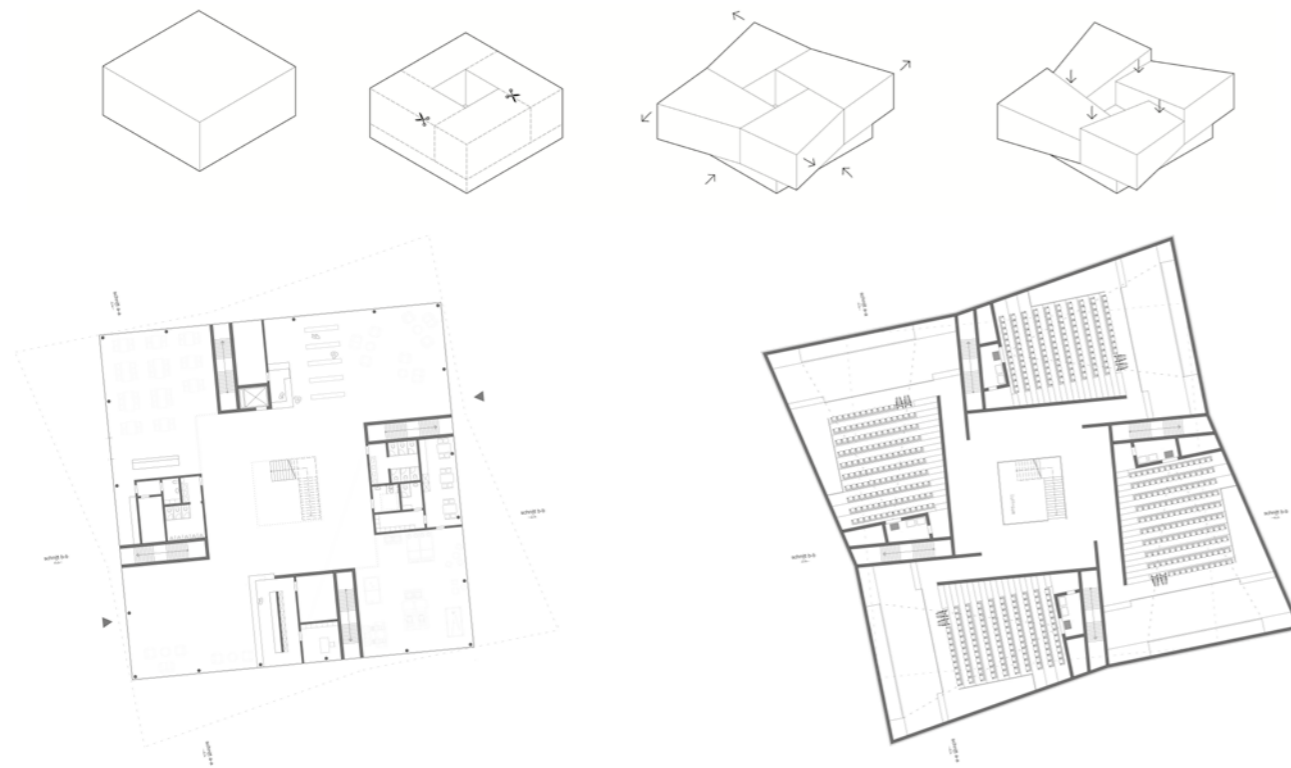

STADTKINO
HALLE

Nu Hong Yen Nguyen
Master Architektur Studio SS 2019
Supervisors: Prof. Dr. Matthias Höhne,
Prof. Andreas Theurer

Der Entwurf erinnert im Grundriss an ein Windrad; das Gebäude nimmt die Verkehrsströme auf und reagiert auf die strenge Blockbebauung der Umgebung, indem es sich trotz seines auffallenden Äußeren gut in die Umgebung einfügt. Die Höhe der Nachbarbauten wird nicht überschritten. Um den öffentlichen Raum zu beleben und die Umgebung städtebaulich aufzuwerten, wird ein Platz mit differenzierten Freiräumen um den neuen Solitär geschaffen. Das Gebäude besteht aus zwei Ebenen. Während der Betrachter nur erahnen kann, was sich hinter der speziellen Form des Obergeschosses verbirgt, öffnet sich das Erdgeschoss in alle Richtungen und verbindet Innen- und Außenraum durch seine transparente Glasfassade. Um die optische Teilung auch in den Funktionen zu stärken, ist das Erdgeschoss als Zentrum des sozialen Austauschs vorgesehen. Alle seine Bereiche sind unabhängig voneinander öffentlich zugänglich. Im Obergeschoss befinden sich die Kinosäle; dahin gelangen nur diejenigen, die eine Eintrittskarte erworben haben. Damit sich die Kinosäle nicht nur durch ihre Form vom Glaskörper abheben, ist ihre Außenfassade zusätzlich mit Cortenstahl verkleidet. Dadurch spiegelt sich die Materialität des Tragwerks wider. Die einzelnen Säle bestehen konstruktiv aus Stahlträgern, die in gleichen Abständen aneinander gereiht sind und durch diagonale Stahlstreben zusammengehalten werden. So ist die Auskragung des Obergeschosses ohne weitere Stützen möglich.

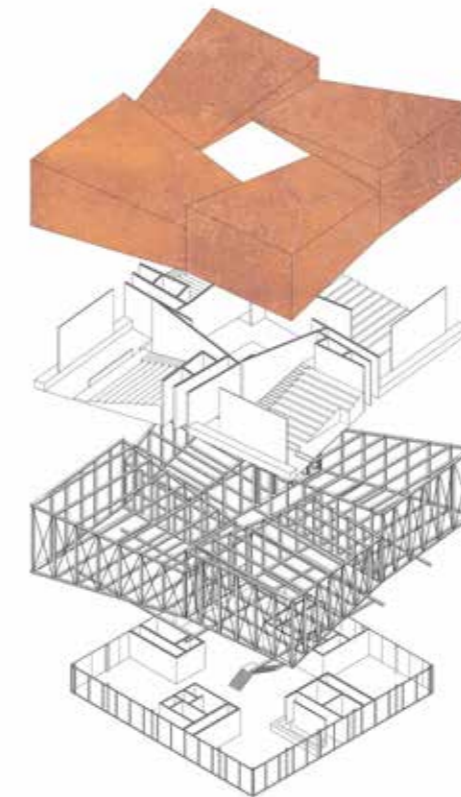

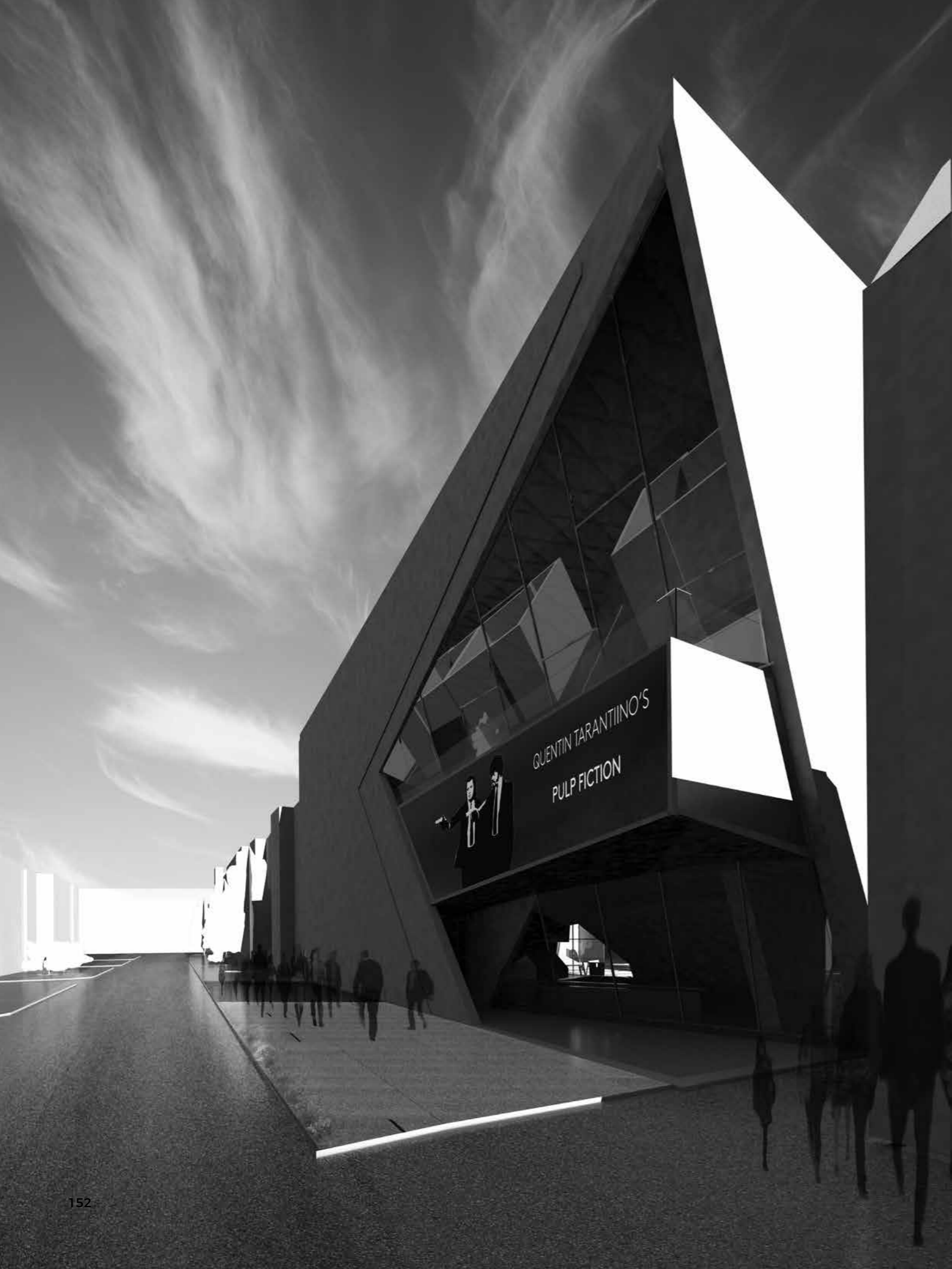

PROGRAMM-STADTTEILKINO
HALLE (SAALE)

Markus Passeck
Master Architektur Studio SS 2019
Supervisors: Prof. Dr. Matthias Höhne,
Prof. Beatriz Möller

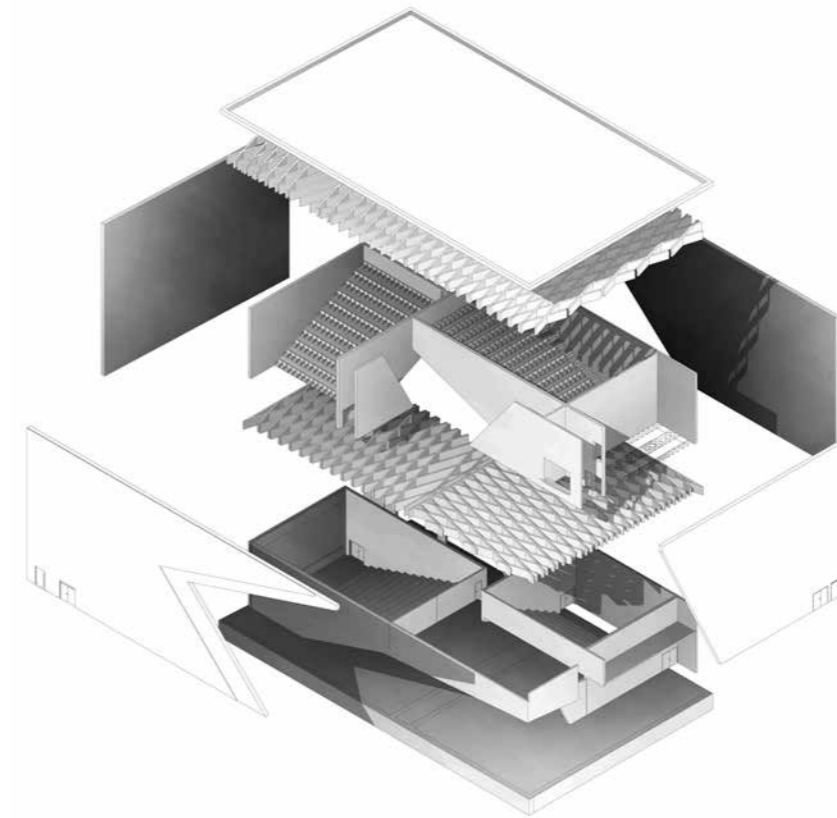

Programmkino – das heißt Independentfilme und künstlerischer Anspruch. Also sollte dieser Art von Filmen auch eine angemessene Kulisse geboten werden. Bestehend aus vier Sälen, gehört dieses Lichtspielhaus zu den kleineren Kintypen. Pro Geschoss sind zwei Säle und diverse Nebenräume vorgesehen. Normalerweise würde man die Leerräume unter den Sälen mit Nebenräumen füllen – nicht aber hier. Hier entsteht »Raum«. Die Verschränkung der verschiedenen Säle schafft eine Komposition aus offenem und geschlossenem Raum. Dieser Eindruck wird durch die schräg zulaufenden Decken – die Unterseiten der Säle – noch verstärkt. Da wir uns hier in einer Baulücke befinden, galt das Motto: wenig Platz, große Wirkung. Besondere Blickbeziehungen ergeben sich durch die in verschiedenen Winkeln zueinander laufenden Wandscheiben und Formen, die den Nutzer auf eine Art Entdeckungsreise schicken. Baukonstruktiv ergaben sich durch dieses Konzept einige Hürden. Da Wände grundrissbedingt nicht immer übereinander angeordnet sein konnten, mussten aus dem Brückenbau bekannte Techniken angewandt werden. Die gesamte Konstruktion besteht aus Wandscheiben aus Beton, die teilweise eingespannt sind. Tragelemente wurden mit einer optischen Funktion belegt, damit der Nutzer diese nicht als solche wahrnimmt.

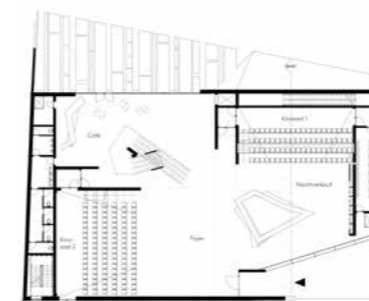

EG

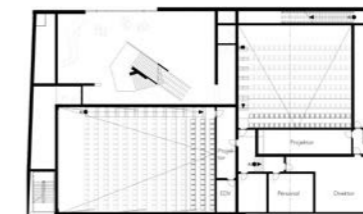

EG + 1

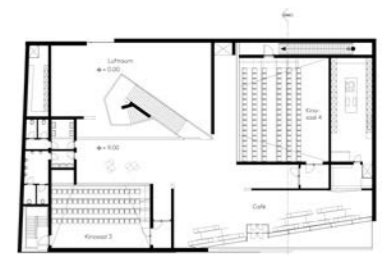

OG



Ansicht West

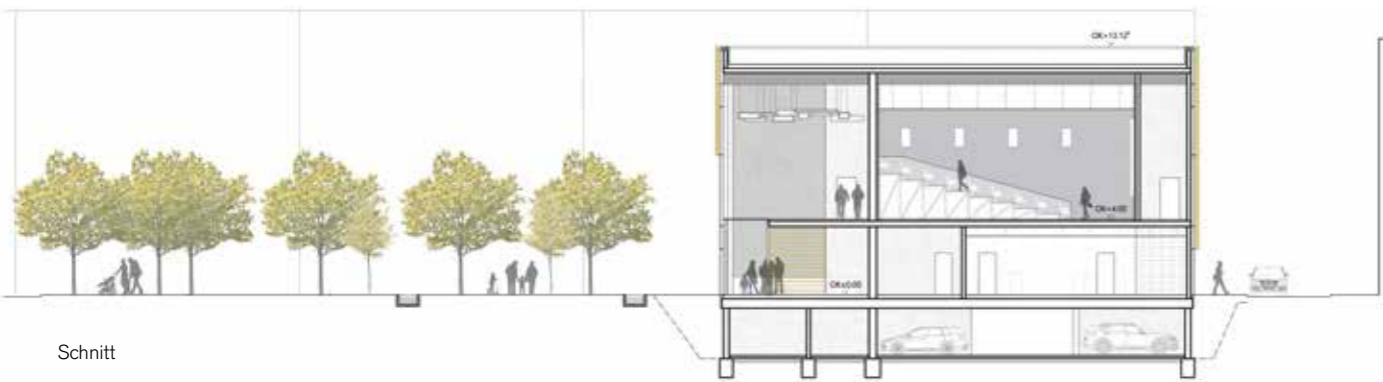

Schnitt

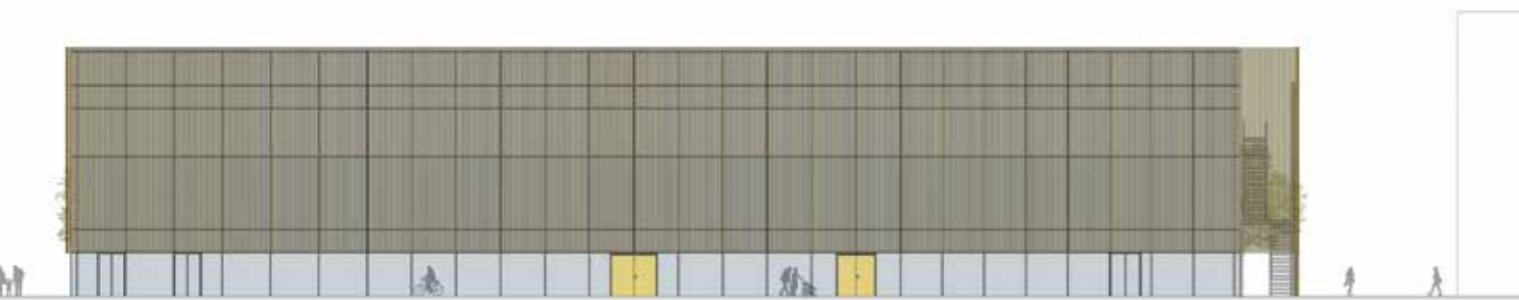

Ansicht Süd



Perspektive Foyer



Perspektive Vorplatz



Lageplan



Erdgeschoss

PROGRAMM-STADTEILKINO
HALLE (SAALE)

Christopher Jakobasch
Master Architektur Studio SS 2019
Supervisors: Prof. Dr. Matthias Höhne,
Prof. Beatriz Möller

Im Zeitalter omnipräsenter Multiplexkino soll dieses Stadteilkino sein eigenes architektonisches Drehbuch schreiben. Der Entwurf verfolgt einen experimentellen Ansatz im Innenraum. Modulare Abtreppungen in den Kinosälen ermöglichen eine flexible Raumpaltung und Bestuhlung. Insgesamt beherbergt das Gebäude vier Kinosäle, zwei mit 144 Plätzen, einen weiteren Saal mit 198 und einen großen Saal mit 284 Plätzen. Die vergleichsweise dezente Fassade in Pfosten-Riegel-Konstruktion öffnet sich zum Eingangsbereich mit großen Glasflächen. An den geschlossenen Wandflächen wechseln vertikale Dämmpaneele und Glaselemente einander ab. So entsteht optisch der Eindruck eines durchgängigen Glaskörpers und zeigt, dass Understatement ebenso anziehend sein kann wie die protzigen Baustile der alten Filmhäuser.

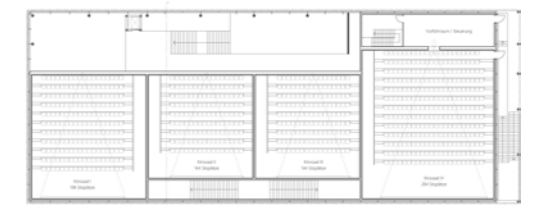

2. Obergeschoss



1. Obergeschoss



Perspektive



Lageplan



Querschnitt

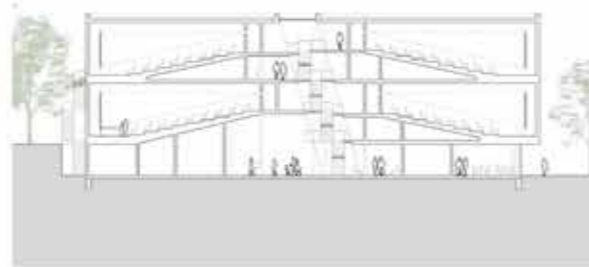

Längsschnitt



FILMPALAST GLAUCHA
KINO IN HALLE

Nathalie Feist
Master Architektur Studio SS 2019
Supervisors: Prof. Dr. Matthias Höhne,
Prof. Andreas Theurer

Das Kino befindet sich im Bereich Südliche Innenstadt in Halle (Saale). Der Ort ist geprägt durch DDR-Plattenbauten, Wohnhochhäuser und Gründerzeitgebäude. Das zu bebauende Grundstück wird im Osten von sechsgeschossigen und im Westen von zehngeschossigen Plattenbauten begrenzt. Im Süden und Norden ist die Bebauung mit zwei bis drei Geschossen vergleichsweise niedrig. Der kompakte Baukörper des Filmpalastes Glaucha befindet sich im Norden, an der Ecke Glauchaer Straße und Jacobstraße. Im Süden wird das Grundstück durch ein viergeschossiges Wohngebäude städtebaulich ergänzt.

Grundidee ist die Teilung eines Quaders durch eine Schräge, so dass die Kinosäle in ihrer Größe variieren. Durch Auseinanderziehen und Verschieben ergeben sich das mittig liegende Treppenhaus und die beiden Eingänge auf der Hof- und der Straßenseite. Aufgrund des ansteigenden Geländes auf dem Grundstück befindet sich die südliche Hälfte des Kinos im Erdreich, die nördliche Hälfte erhält ein verglastes Erdgeschoss. Eine Besonderheit stellt die lichtdurchlässige Fassade dar. Bei Dunkelheit setzen mit LED-Lampen beleuchtete Fugen ein flimmerndes Zeichen im Stadtraum.

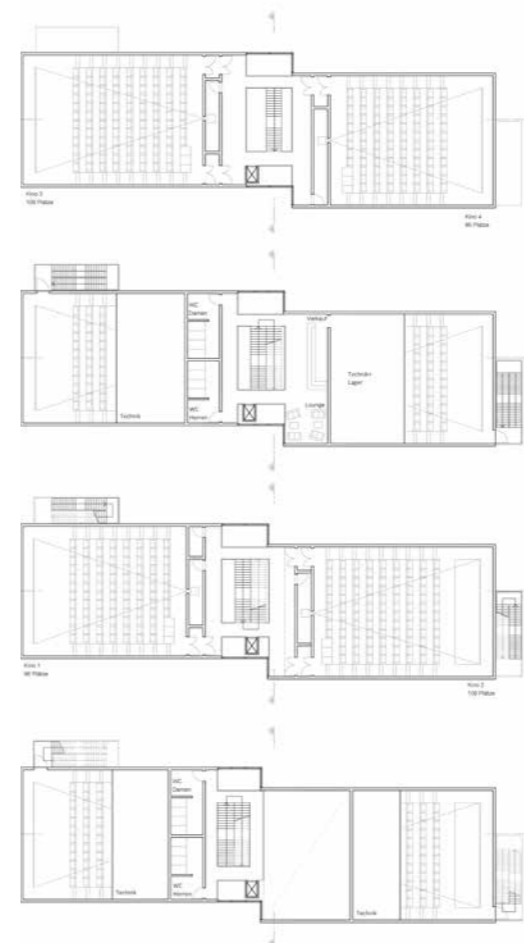

Ebene 4

Ebene 3

Ebene 2

Ebene 1

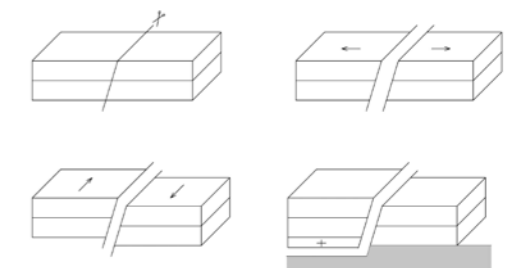

Prinzipskizzen



BAULÜCKENSCHLISSUNG
DESSAU NORD

Markus Passeck, Tobias Rümmler
Master Architektur Studio WS 2018/19
Supervisors: Prof. Beatriz Müller,
Susanne Herz

Das Schließen von Baulücken ist eines der zentralen Elemente der Nachverdichtung. Diese Entwurf ist gedacht als Demonstration modellhafter Stadtreparatur, um Potenziale für eine innerstädtische Verdichtung mit Wohnbauten zu definieren. Es handelt sich hier um die klassische Form der Baulücke, bei der ein unbebautes Grundstück innerhalb einer geschlossenen Bebauung vorliegt. Ziel des Entwurfs war es, eine Abschirmung des Gebäudes zur Straße hin zu erreichen, indem eine Privatheit entsteht, die in der Regel den Bewohnern Ausblick verschafft, ohne dabei selbst gesehen zu werden. Der »in sich gekehrte« Charakter entsteht unter anderem durch einen durchgängigen Lichtschacht, der die Räume über vier Geschosse miteinander verbindet und natürlich belichtet.

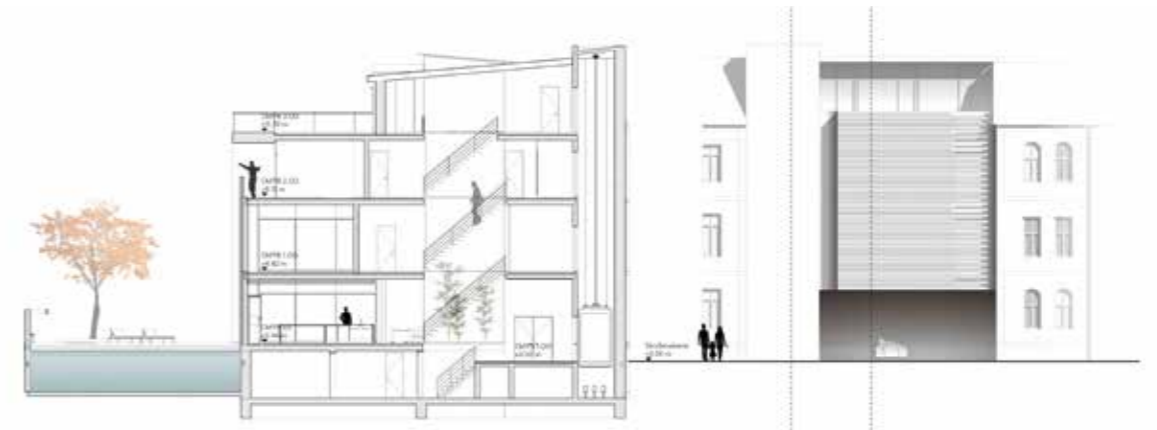

Schnitt / Ansicht

Grundrisse



Kellergeschoss

Erdgeschoss

1. Obergeschoss

2. Obergeschoss

3. Obergeschoss

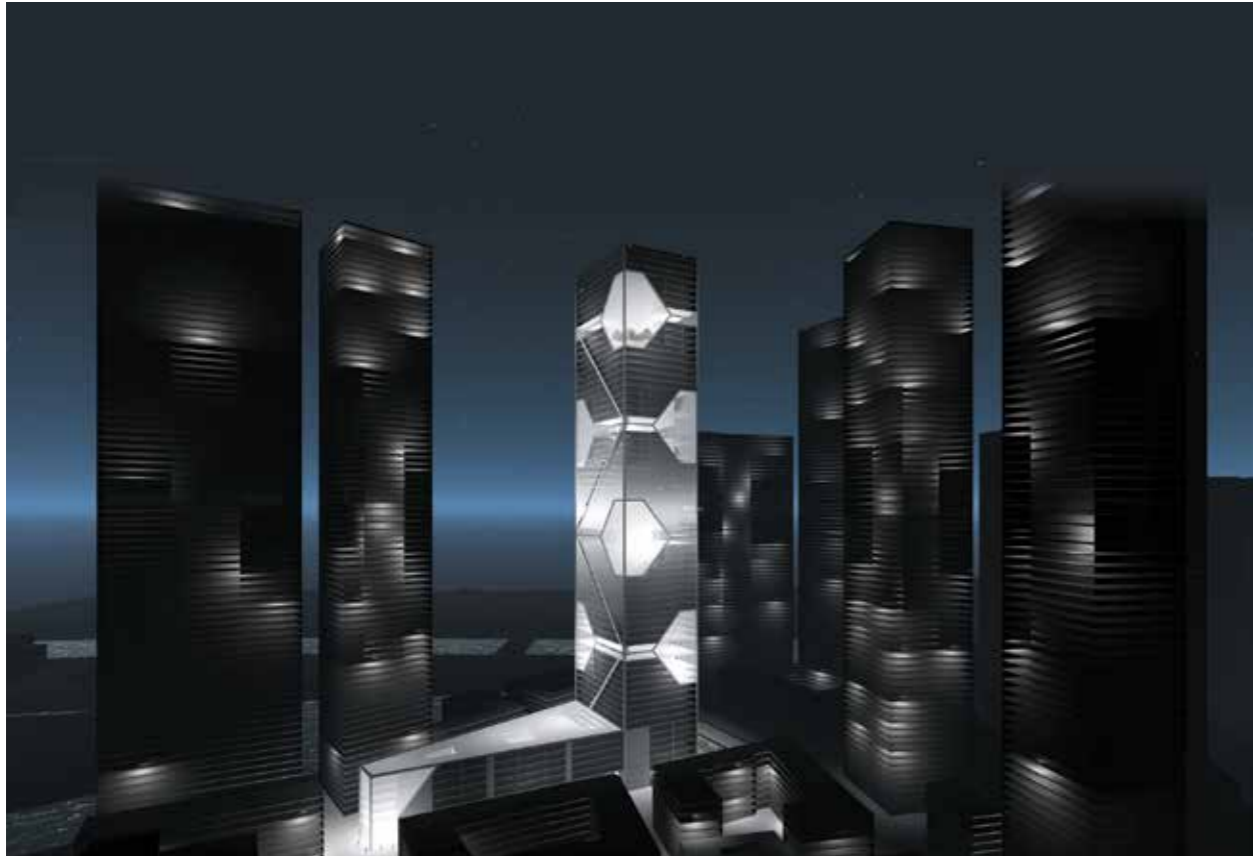

VERTICAL CITY
FRANKFURT

Maria-Luisa Günther,
Christopher Jakobasch
Master Architektur Studio WS 2018/19
Supervisors: Prof. Dr. Matthias Höhne,
Prof. Andreas Theurer, Peter Weber

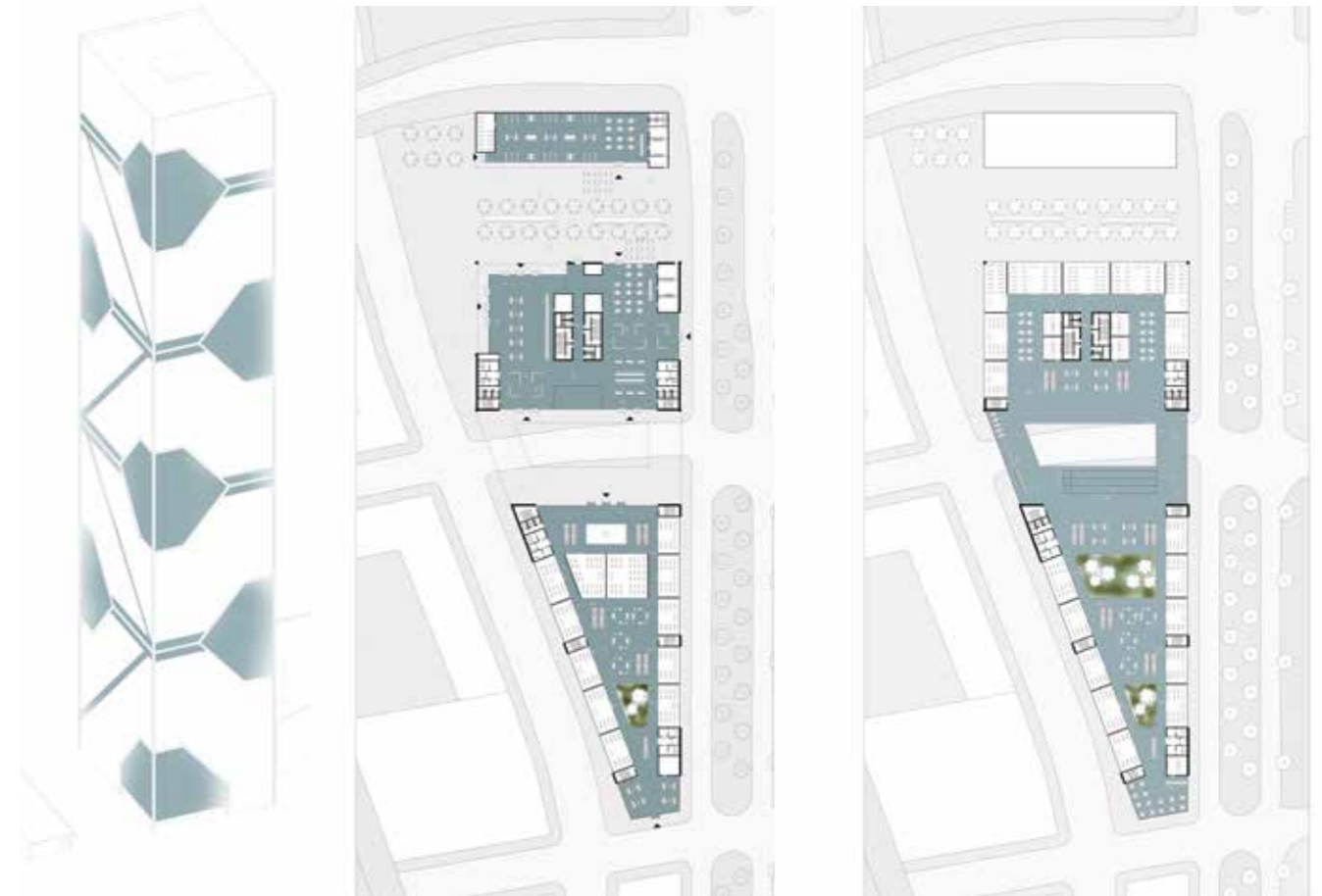
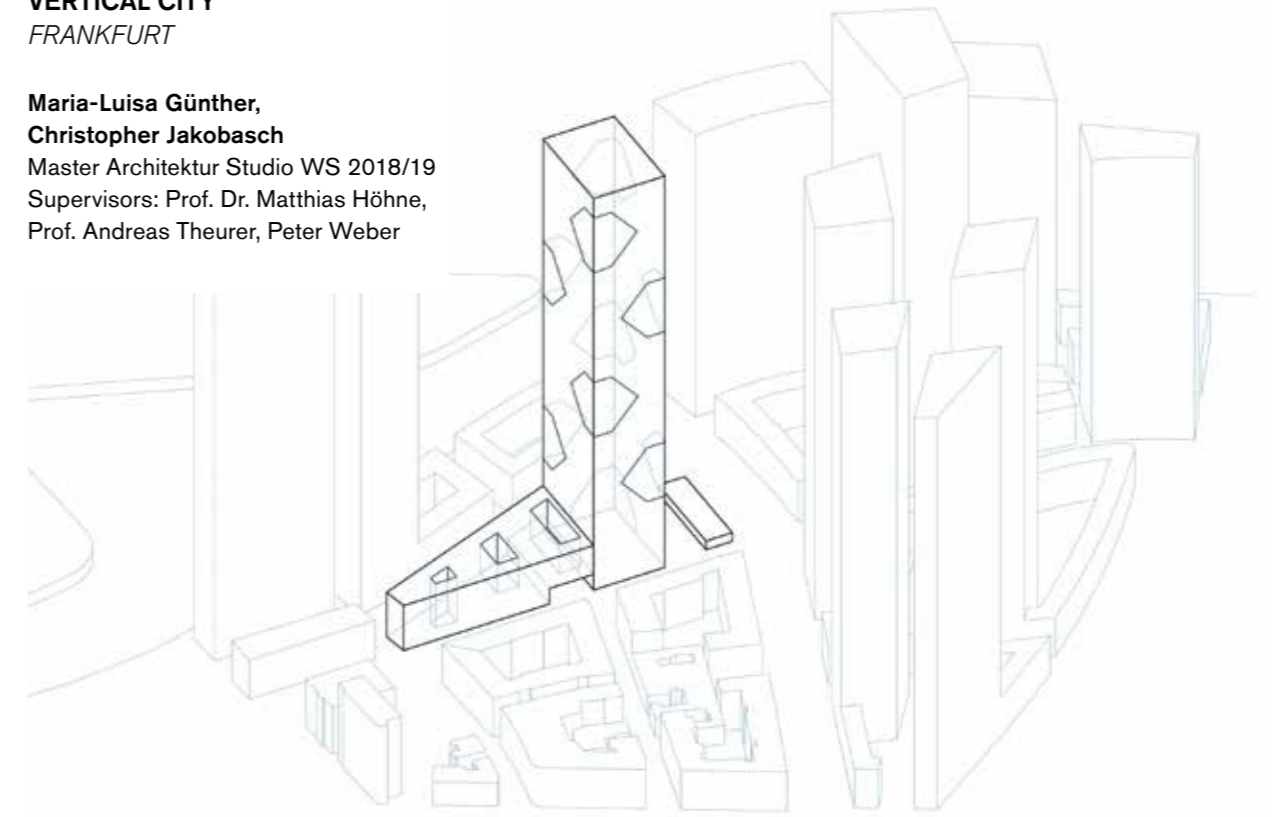

Studie

Erdgeschoss

Obergeschoss

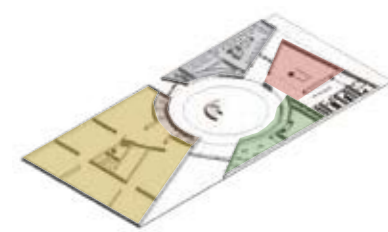

Grundriss EG

- Foyer
- Forum
- Hauptausstellung
- Verwaltung
- Café



Grundriss OG 1

- Foyer
- Hauptausstellung
- Verwaltung
- Shop
- Café



Grundriss OG 2

- Foyer
- Hauptausstellung
- Wanderausstellung

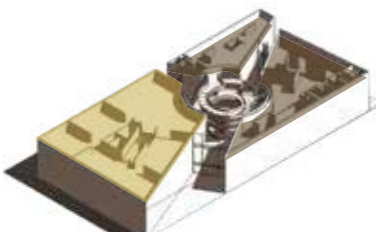

Grundriss OG 3

- Foyer
- Hauptausstellung
- Wanderausstellung



Grundriss Erdgeschoss



Ansicht West

Ansicht Süd

Lageplan

ARCHITEKTURMUSEUM
MÜNCHEN, XELLA-AWARD

Markus Passeck / Janick T. Schmid
Master Architektur Studio WS 2018/19
Supervisors: Prof. Andreas Theurer,
Peter Weber

Das Kunstareal München ist ein historisch geprägtes Quartier für Kunst, Kultur und Wissen, das um einen Museumsbau erweitert werden soll. Ziel des Entwurfs war es, einen Ort zu schaffen, der neben Archivarbeit und Ausstellungen auch Diskussionen, Präsentationen und Workshops zulässt. Der Zugang erfolgt über eine akzentuierte Geste: einen scharfen Einschnitt in die strenge Gebäudekubatur. Über eine kreisförmige zentrale Halle mit spiralförmiger Treppe, die bis zum Glasdach reicht, werden alle Ebenen erschlossen. Die Entwurfsverfasser knüpfen damit an die Rampe des Guggenheim-Museums in New York an. Im Gegensatz zu diesem dient der Wandelgang hier lediglich der Erschließung. Die Kunstwerke werden in unveränderter Museumstradition nach chronologischen oder thematischen Kriterien präsentiert.



»Alltagsarchitektur ist die Architektur der funktionalen System-Typen.«

Stephan Baumgartl

Foto: Jan Büchschuß

Janet Landwehr

Die Problematik, ob sich Architektur in »Kunstabauten« und »Alltagsarchitektur« unterscheiden lässt, konnte abschließend anhand einer Funktionsbestimmung geklärt werden. Der Parameter »Ästhetik« hat sich als unzureichend erwiesen, um »Kunstwerke« zu definieren und von anderen Bauwerken und Gebäuden abzugrenzen.

Demnach zählen Bauwerke und Gebäude zur Alltagsarchitektur, wenn sie eine direkte Funktion erfüllen. Dies bedeutet, dass die Alltagsarchitektur direkt vom Menschen genutzt werden kann und direkt und merklich das Leben der Menschen beeinflusst. »Kunstabauten« hingegen sind diejenigen Bauwerke und Gebäude, die nur indirekt bzw. gar nicht vom Menschen genutzt werden. Sie erfüllen Funktionen, derer sich die Menschen nicht bewusst werden, die dennoch eine wichtige Rolle spielen. Somit zählen Statuen und Denkmäler zu den »Kunstabauten«, während Brücken und Gebäude der Alltagsarchitektur zuzuordnen sind. Diese Definition fasst alle Gebäude und Bauwerke zur Alltagsarchitektur zusammen, die eine direkte Funktion erfüllen. Inwieweit diese unkonventionell oder ästhetisch sind, spielt keine Rolle mehr, wodurch die Definition objektiver wird.

Ohoud Asharedah

Der Sinn des Bauens ist es, einerseits den Menschen vor Klimaeinflüssen, Tieren und Fremden zu schützen, andererseits seinen Wohlstand zu zeigen. ...

Durch die Globalisierung eröffneten sich neue Möglichkeiten und Ideen, um den Menschen zu repräsentieren. Anstatt die eigenen traditionellen Bauweisen zu verbessern und weiterzuentwickeln, richtete sich der Fokus mehr und mehr auf die Ästhetik des modernen Baustils. Dabei vergaß der Mensch jedoch den Zweck beziehungsweise die Aufgabe seines Heims, sich an das Klima und die Umgebung mit den gegebenen Ressourcen anzupassen. ...

Dadurch entstand meiner Meinung nach eine schlichte Architektur, die keinen Sinn in ihrer Existenz hat, sondern eine verzerrte Kopie ist, die in den meisten Fällen keine Qualität in sich hat, sondern nur Ästhetik. ...

Es gibt keine Alltagsarchitektur, die Hunderte Jahre unter dem Namen Alltagsarchitektur Bestand hat, sondern sie verändert sich je nachdem, welche Gedanken die Gesellschaft hat und welche Einflüsse auf sie einwirken.

THEORIE DER ALLTAGSARCHITEKTUR

Architekturtheorie WS 2018/19
Supervisor: Dr. Jan Büchschuß

Architekturtheorie darf nicht nur das Sich-Gedankenmachen über bereits gemachte Gedanken sein, sondern sollte als praxisnahe Methode erlebt werden, um das eigene Tun zu hinterfragen. Idealerweise lässt sich das durch Themen vermitteln, die kaum durch Fachliteratur kontaminiert sind. Alltagsarchitektur prägt unsere Gesellschaft weit mehr als das seltene Architekturkunstwerk; doch nur wenige sprechen darüber. Die Studierenden waren aufgefordert, dieses noch unentdeckte Terrain zu erkunden. Nur etwa 5 Prozent der gebauten Umwelt werden in den einschlägigen Architekturkreisen und -medien diskutiert, gelobt, kritisiert, bewundert oder verachtet (Meinhard von Gerkan: Alltagsarchitektur – Gestalt und Unge-stalt). Das bedeutet im Umkehrschluss, dass über die restlichen 95 Prozent des Bauwesens keine architekturelevante und öffentlichkeitswirksame Diskussion stattfindet. Dabei prägen diese 95 Prozent Alltagsarchitektur allein aus quantitativen Gründen unsere Umwelt und damit indirekt auch unsere Gesellschaft weit mehr und weit nachhaltiger als das originelle und außergewöhnliche Architekturkunstwerk. Im Rahmen des Seminars sind die Studierenden aufgefordert, dieses anscheinend noch unentdeckte Terrain der Architekturlehre und Architekturtheorie zu erkunden. Dabei zielen die thematisch aufeinander aufbauenden Gesprächsrunden nicht nur auf die Entdeckung von Fakten und Argumenten zu einer Theorie der Alltagsarchitektur ab, vielmehr wird die Architekturtheorie als Methode in das Bewusstsein gebracht.

Stephan Baumgartl

In der Alltagsarchitektur gilt ein auf Konvention beruhender Zusammenhang durch Typologisierung und Serialisierung von angestrebten Formen, Funktionalität sowie gewohnheitsgemäßen Gebräuchen, die einen Architektur-Code ergeben. Bricht man aus diesem Code aus, spricht man nicht mehr von Alltagsarchitektur. ...

Alltagsarchitektur ist die Architektur der funktionalen System-Typen. Optimiert und standardisiert für spezifische Nutzergruppen, relativ unflexibel in der Variation architektonischer Komponenten, dafür viel Raum lassend für die kreative Individualisierung durch den Nutzer in den architektonisch eher peripheren Bereichen. Der Parameter der Architektur spielt aus der Sicht des Nutzers innerhalb der Alltagsarchitektur eine untergeordnete Rolle.

Nico Sanne

Der Großteil der Weltarchitektur befindet sich direkt in den Kleinstädten, hinter den liebevoll angelegten Vorgärten, oder im Zentrum der Großstadt neben den großen Einkaufszentren. Die Rede ist von der alltäglichen Architektur, den Mehr- und Einfamilienhäusern, den Bürogebäuden oder den Einkaufsmärkten. ... Einen äußeren interessanten ästhetischen Eindruck bietet das Standardhaus zwar nicht wirklich, was aber an dem funktionalen städtebaulichen Bild liegt. Da aufgrund der Mehrzahl aneinandergereihter Häuser mit demselben Baustil keine wirkliche Vielfalt verschiedener Architektur entsteht.

Viele Bauunternehmen und Fertighaushersteller nutzen diese Marktlücke nun aus und bieten auf den ersten Blick optisch attraktivere Alternativen zu den standardmäßigen Einfamilienhäusern an. Sie werben mit Häusern im Landhausstil, Bauhausstil oder sogar amerikanischen beziehungsweise toskanischen Stil. Zwar bringt die Fertighausindustrie somit eine Differenzierung in das alltägliche Stadtbild, jedoch auf Kosten des Städtebaus und der damit verbundenen Funktionalität der Alltagsarchitektur.



TENSILE STRUCTURES
SUSPENDED CONOIDS IN BUILDING
DURANGO/MEXICO

Samuel Alejandro Carrillo Garcia
Master Membrane Structures
Supervisor: Prof. Dr. Robert Off
iaa IFAI International Achievement Awards
Award Winner 2018



The purpose of this tensile structure was mainly to provide protection from sun and rain for a communal area for university students. The client requested a solution that could be quickly implemented and that would function as an icon to identify the university. Apart from the dynamism of the form in conjunction with the inclined masts and the perimeter of the irregular rigid and wave-like structure, this concept was based on the mountains that surround this building in the city of Durango in Mexico. The steel structure is anchored by steel columns directly to concrete columns of the same building, the rigidity of the conoids was provided by cables and masts with a system that makes it possible to use height to obtain a greater tension of the fabric. The whole tension system is anchored to the perimeter framework of structural steel.

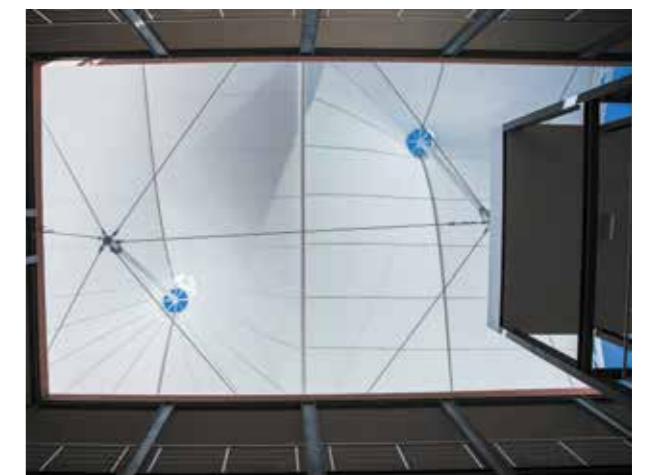



HORNET NEST
A DIGITALLY FABRICATED PAVILION

Mahmoud A. Elnaggar,
Andrea Ordevska, Lisa Petzold,
Maria Quittenbaum
 Master Architecture SS 2018
 Supervisor: Karim Soliman

Inhalt des Kurses *Digital Fabrication Pavilion* war die Entwicklung komplexer parametrischer Strukturen. Aus sieben Projekten wurde im kursinternen Wettbewerb das Projekt *Hornet Nest* zur Realisierung ausgewählt – selbsttragend, vielseitig nutzbar und simpel im Auf- und Abbau.

Die Elemente sollten ohne Ausnahme gesteckt werden, Schrauben waren nicht erlaubt. Die Tragstruktur entsteht durch drei verschiedene Komponenten – orthogonal ineinander gesteckte horizontale Elemente bilden Bögen, die mit vertikalen Verbindungsstücken ein ausgestiftetes System bilden. Das Designteam arbeitete gemeinsam mit dem Berliner Ingenieurbüro Happolt an der Umsetzung und stellte das Projekt zum Campusfest 2018 fertig.

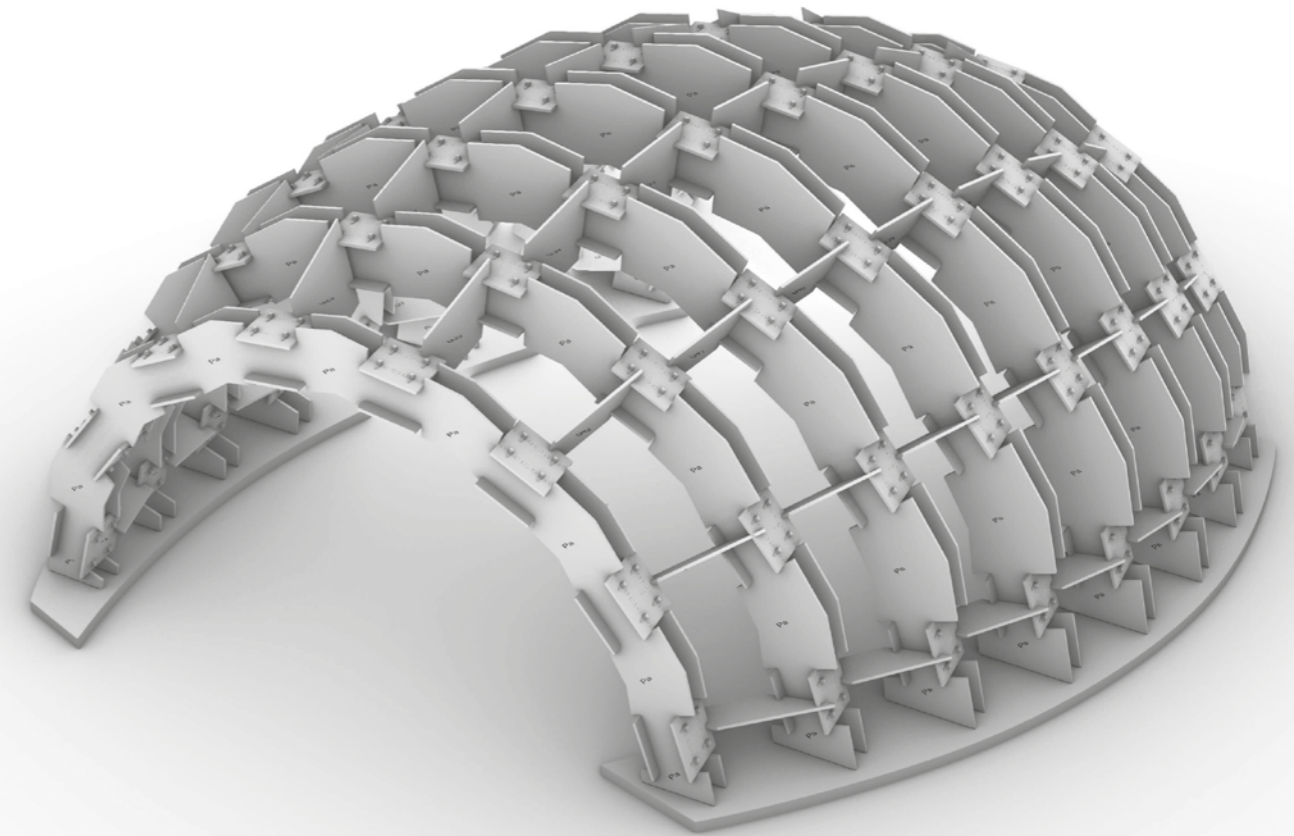
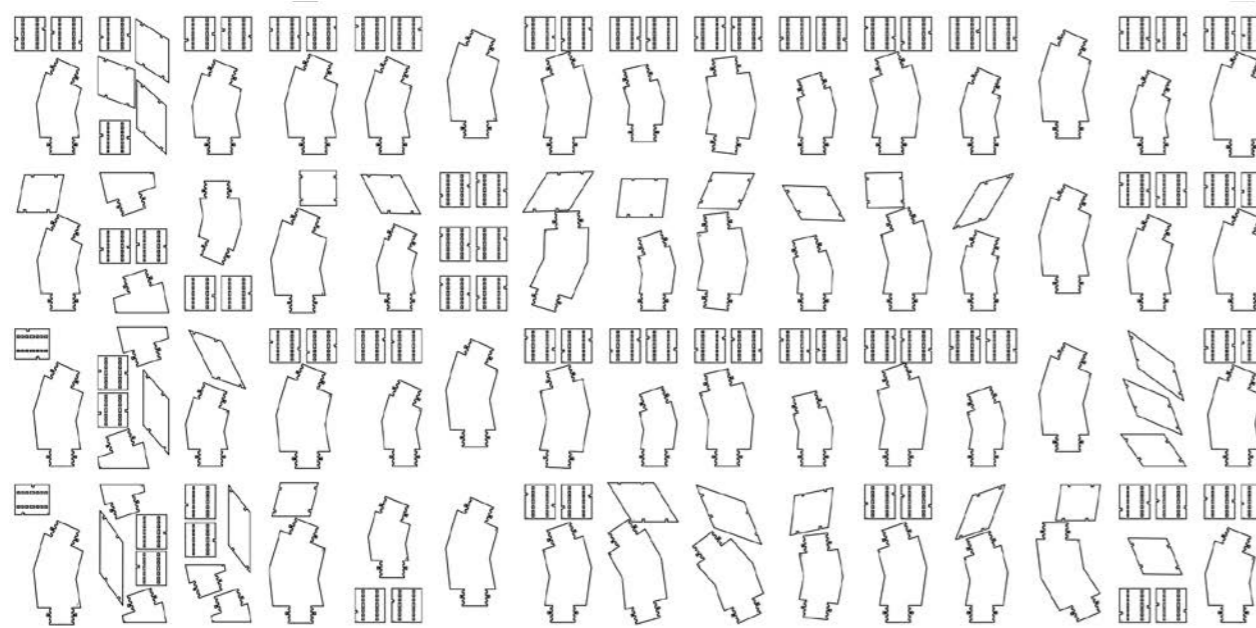



Gleichseitiges Dreieck: Ahmad Alsaied, Marija Vujovic

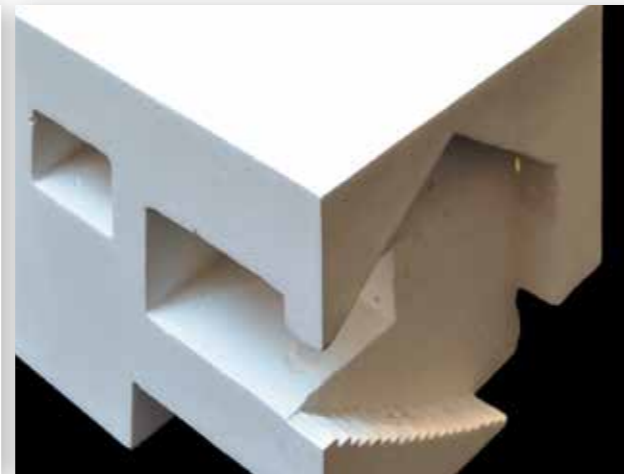
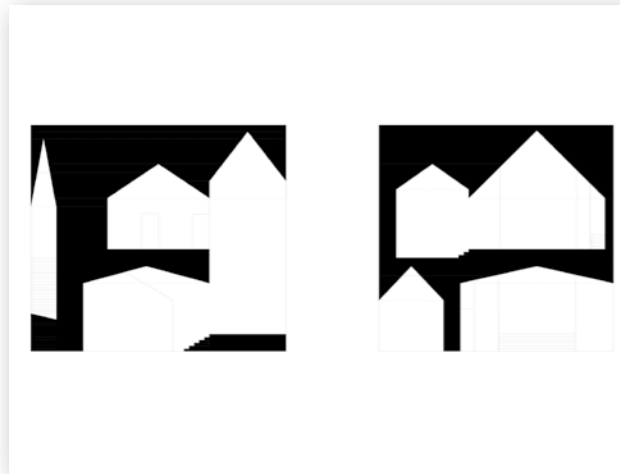

Gleichschenkliges Dreieck: Lingyue Zhao, Tingting Wu

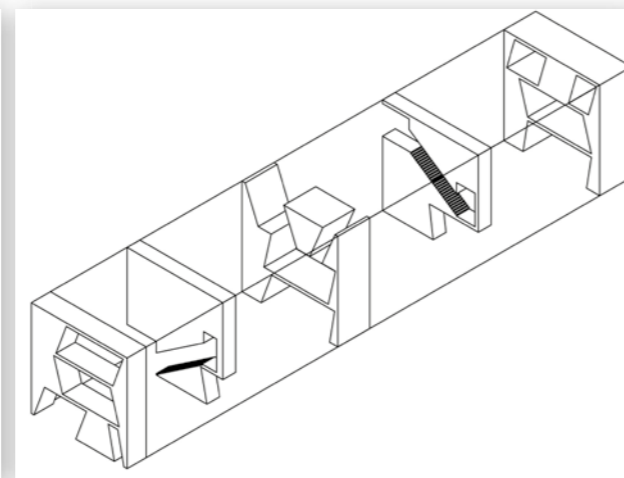
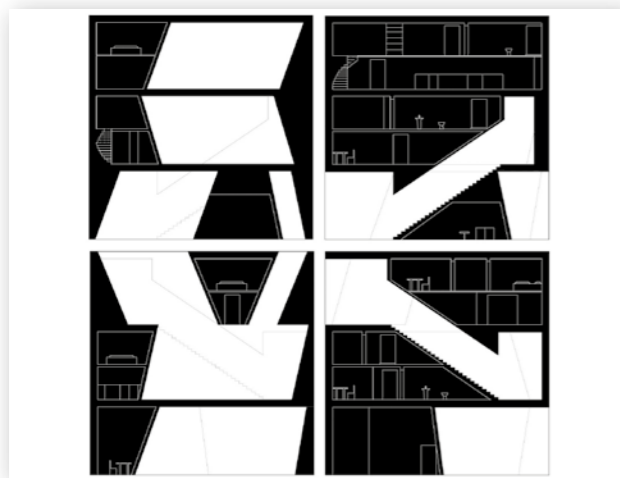

Parallelogramm: Anita Bärish, Julia Krüger

GESCHICHTE THEORIE METHODEN FIGUR-GRUND-KONTINUUM

Architektur Master SS 2018
Supervisor: Dr. Karsten Schubert

Im Pflichtmodul *Geschichte – Theorie – Methoden* gewinnen die Studierenden nicht nur einen Einblick in architekturhistorische Entwicklungen und architekturtheoretische Diskussionen; darüber hinaus werden architektonische Themen und theoretische Erkenntnisse mithilfe von praktischen entwerferischen Übungen reflektiert und nachvollzogen. Wöchentliche Vorlesungen und Analysen von Texten werden von betreuten Wochenaufgaben begleitet, in denen der theoretische Inhalt in methodisches Entwerfen zu übersetzen ist. Abgeschlossen wird das Semester mit einem vierwöchigen, auf den Vorübungen aufbauenden Kurzentwurf. In jedem Semester bildet ein Thema den

Ausgangspunkt einer forschenden Entdeckungsreise (Proportion, Ordnung, Erschließung, Fassade ...). Im SS 2018 beschäftigten wir uns mit dem Verhältnis von Körper und Raum in der Architektur und loteten das entwerferische Potenzial eines spezifischen Konzepts des architektonischen Raums aus: des von Bernhard Hoesli in den Achtzigerjahren geprägten Begriffs des Figur-Grund-Kontinuums. Körperliche Bauteile und der Raum zwischen diesen bedingen einander und sind, so Hoesli, gleichwertig.

Das Konzept des Figur-Grund-Kontinuums ermöglicht den ambivalenten Ausgleich zwischen zusammenhängendem Raumkontinuum und separierten Einzelräumen. Im Kurzentwurf wurden durch die aus der Theorie angeregte Entwurfsmethodik Wohnhäuser gestaltet, die nicht nur zum Wohnen geeignet sind, sondern verschiedenste, sich immer neu wandelnde Aneignungsformen evozieren. Ausgangspunkt und »Material« des Entwurfs waren 16 geometrische Grundfiguren.

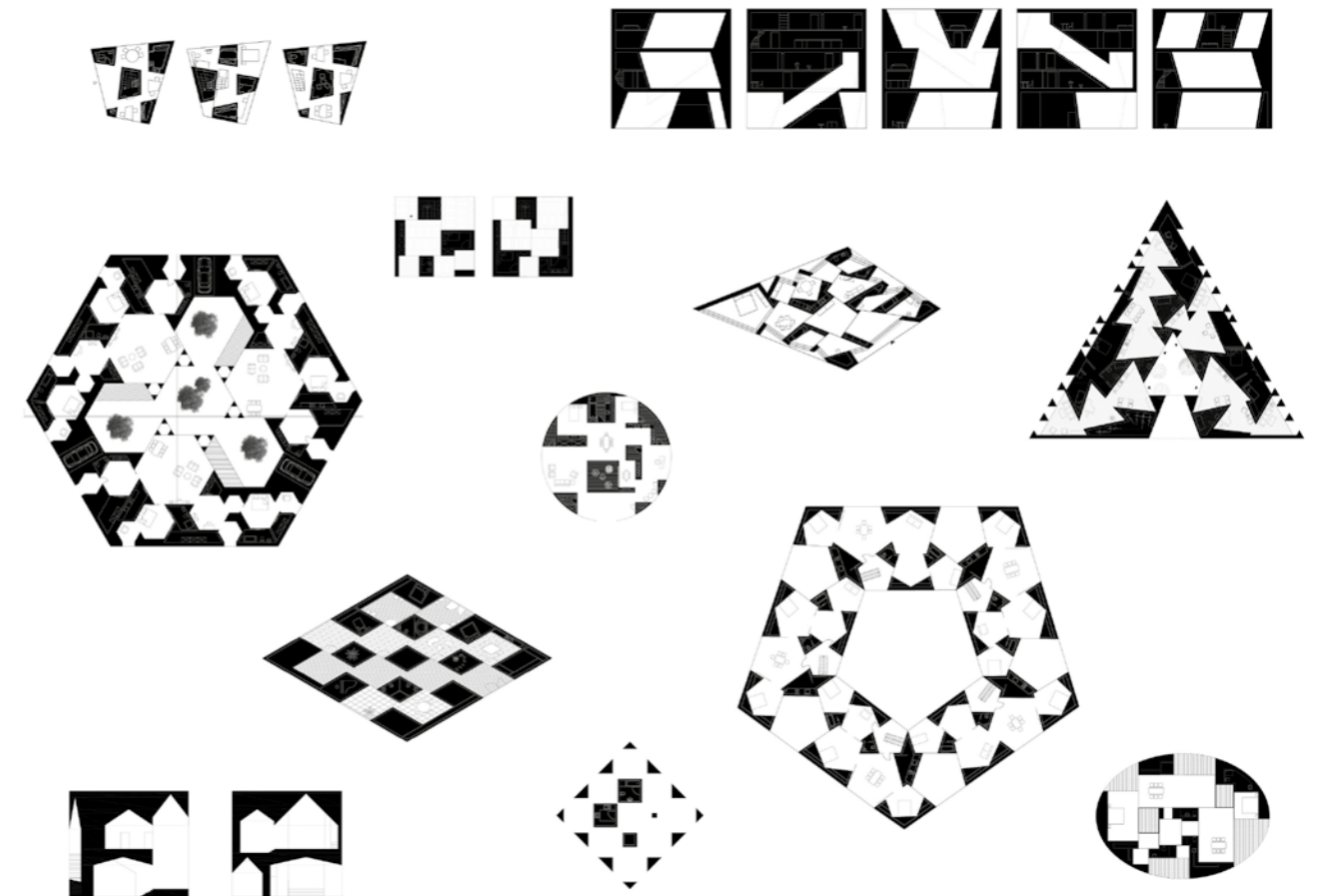



Bröderhof
Ground Floor/Section

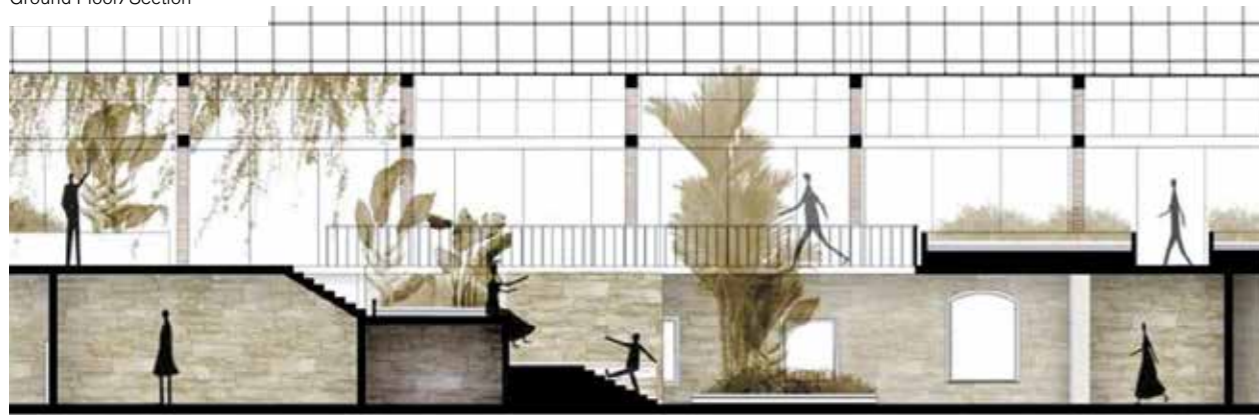

Green House
Vertical Garden: Rendering and Details

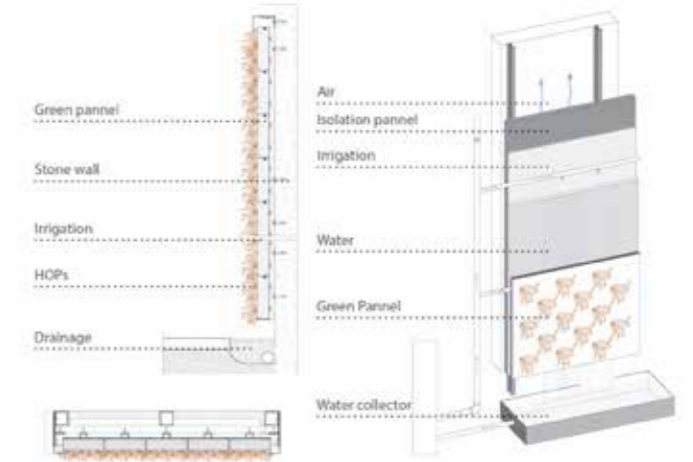

REVITALIZING HUY CASTLE
DESSAU SUMMER SCHOOL

**Flavia Chiste, Polina Kozhevatoa,
Megi Sinani**
COOP SS 2018
Supervisor: Prof. Stephan Pinkau

The studio focused on revitalizing an ancient demesne, part of a Benedictine monastery. Its history can be traced back to its foundation in 1080. A number of Benedictine monks are running this monastery and the program it offers to guests and visitors. The surrounding landscape is picturesque, and only sparsely populated. The demesne was used for farming, living and furthermore used to house a brewery. These buildings belong to the monastery

but are now abandoned and in ruins. As part of the studio, we visited the monastery several times. We learned about its current situation and analysed the potential it provides for future developments. We researched the historic construction and developed concepts and designs for revitalizing it. The head of the monastery, Bruder Jakobus Wilhelm, provided us with the information needed and took part in our presentation.

BRANDSCHUTZ IM BAUDENKMAL AM BEISPIEL EINER WINDELBODENDECKE

Carmen Ewert
Master Denkmalpflege SS 2018
Supervisors: Prof. Dr. Rudolf Lückmann,
Prof. Dr. phil. habil. Leonhard Helten

Denkmalverträglicher Brandschutz, seine Regeln und Maßnahmen sind Thema dieser Arbeit. Untersucht wurden schutzzielorientierte Brandschutzmaßnahmen am Beispiel einer Windelbodendecke, einer der ältesten Bauarten von Holzbalkendecken. Diese auch als Wellerdecke oder Stakendecke bekannte Decke wurde aus mit Strohlehm umwickelten Staken hergestellt. Es sollte geklärt werden, ob eine brandschutztechnische Ertüchtigung dieses Deckentyps erforderlich ist. Der Praxisbezug spielte dabei eine bedeutende Rolle; die Untersuchung wurde daher von Versuchen begleitet. Eine selbst angefertigte Deckenkonstruktion wurde einem Brandversuch nach DIN EN 1363-1 unterzogen. Bei diesem Experiment wurde untersucht, welche brandschutztechnische Einstufung der Feuerwiderstandsklasse der vorgefertigte Prüfkörper besitzt. Des Weiteren wurden Feuerwiderstandsklassen an der Windelbodendecke geprüft unter der Annahme, dass die Widerstandsklasse F30 korrekt ist. Bei negativem Ergebnis wurden Ertüchtigungen untersucht, um die erforderlichen Brandschutzziele zu erreichen – bei gleichzeitiger Konformität mit den denkmalpflegerischen Anforderungen. Die Versuchsergebnisse wurden ausgewertet und analysiert; Ziel war es, notwendige Ertüchtigungsmaßnahmen vorzusehen.



Prüfversuche im Labor

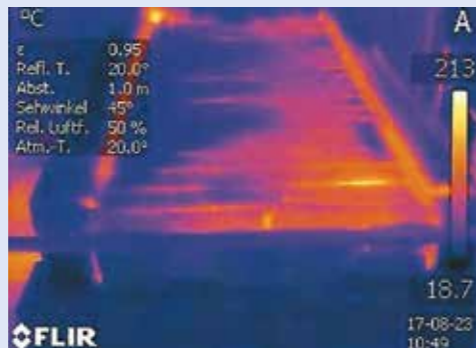

Prüfdecke bei
213 Grad Celsius



Prüfdecke nach
Brandversuch



Prüföfen mit Brandresten

BAUEN MIT RUINEN NEUKONZEPTIONIERUNG ODER VERFALL

Maria Blunk
Master Denkmalpflege SS 2018
Supervisors: Prof. Klaus Kozel,
Prof. Dr. phil. habil. Leonhard Helten

Bauen im Bestand wird in den nächsten Jahren immer mehr zum zentralen Thema und zur Aufgabe für Politiker, Bauherren, Investoren und Architekten werden. Ein wichtiger Aspekt dabei ist der Erhalt historischer Bauwerke, denn sie sind stadtbildprägend sowie wichtige Zeitzeugen vergangener Epochen und architektonischer Gestaltungsweisen. Doch es scheint nicht immer leicht zu sein, in unserer heutigen pulsierenden Zeit das baukulturelle Erbe zu bewahren. Fakt ist, dass in den meisten Fällen für die Bauten eine Chance zur Erhaltung besteht, bevor ein eventueller Abriss erfolgt.

Als denkmalreiche Stadt verfügt Leipzig über eine große Menge an historischer Bausubstanz. Innerhalb dieser gibt es jedoch Bauwerke, die aufgrund von Leerstand und fehlender Sicherung dem Verfall und Vandalismus schutzlos ausgesetzt und in Vergessenheit geraten sind. Allesamt waren diese Gebäude einst belebte Orte, doch aufgrund verschiedener Faktoren standen sie lange leer und verfielen zu modernen Ruinen (Lost Places). Das 1912 erbaute Stadtbad im nördlichen Zentrum (Nordvorstadt) von Leipzig ist das populärste Beispiel. Durch eine gemeinnützige Förderstiftung gerettet, wird es derzeit zu einem Teil als Eventfläche vermarktet. Ein großer Bereich dieser Badeanstalt ist jedoch immer noch ungenutzt und verfällt weiter.

Den Verfall von Baudenkmalern zu stoppen und diese neuen Nutzungen zuzuführen, bedeutet auch Ressourcen zu schonen – ein nachhaltiger, positiver Beitrag zur Entlastung und zum Schutz unserer Umwelt. Allerdings muss

der Erhalt immer gewollt sein. Nachhaltigkeit hört dort auf, wo dem Gebäude eine ungeeignete Nutzung aufgezwungen wird. Auch nach einer Neukonzeptionierung muss das Bauwerk mit seiner Historie authentisch und erlebbar bleiben. Jegliche Abweichung von der eigentlichen Nutzung, sei es durch Um- und Anbauten, Aufstockungen, Sanitär- oder Technische Einrichtungen, greift stets auch in die Altbausubstanz ein.

Nicht immer ist es leicht, eine würdige neue Nutzung zu finden, so dass das Baudenkmal mit der Zeit dann doch verfällt. Die untersuchten Beispiele standen ebenfalls lange leer und wurden ruinös. Um diesen stetigen Verfall bei nicht vorhandener Neukonzeptionierung aufzuhalten, bedarf es der Entwicklung eines Erhaltungskonzepts, damit die Bauwerke ausreichend gesichert werden können, um so lange zu bestehen, bis ein geeignetes Umnutzungskonzept gefunden ist. Mitunter beginnt dies damit, dass leer stehende Bauwerke umfassend vor Witterungseinflüssen, aufsteigender Feuchte und Vandalismus geschützt werden. Im Sinne des Gebäudes sollte stets eine bedachte Ausarbeitung der Umnutzung erfolgen. Viel hängt hier von dem jeweiligen Denkmalpfleger, Architekten oder der Denkmalbehörde ab. Nur in der Zusammenarbeit können sie voneinander profitieren.

Das Interesse an Bau- und Kulturdenkmälern wird in der Öffentlichkeit immer größer. Es ist eine besondere Herausforderung an die Denkmalpflege, bedeutende historische Bauwerke behutsam zu erhalten. Nur so kann die Vergangenheit auch für die Zukunft sichtbar bleiben.



Frauenschwimmhalle, Stadtbad Leipzig (2016)
Foto: Panther Media GmbH



Ruherraum der Orientalischen Sauna, Stadtbad Leipzig (1916)
Foto: Aclosund Historic



links: Wohn- und Galeriehaus für Rudolf Zwirner in Köln mit Fassade in Sichtbeton aus dem Jahr 1972. Architekt: Prof. Erich Schneider-Wessling (1931–2017), ein Pionier des ökologischen Bauens.

Foto: Matthias Höhne (1992)

rechts: Heute ist der Beton unter einer neuen mehrschaligen Fassade verschwunden und in seiner architektonischen Ursprünglichkeit verloren.

Foto: Matthias Höhne (2011)

Energy-efficient architecture – What is our architectural heritage worth? *In memory of Erich*

Prof. Erich Schneider-Wessling, one of West Germany's major architects, died in Cologne on 28 September 2017. I first started my career in 1989 in his office in the "Bauturm", a community of architects he founded in 1968 together with Peter Busmann. These very formative experiences as a young architect actually involved in planning have stayed with me until this day. During the memorial service at his funeral, a picture sequence once more reminded us of his architecture from three decades. In this series of works, I particularly noticed the exposed concrete buildings. To me, from an East German perspective, raw concrete buildings such as Albertusstraße 18 in Cologne are part of West Germany's most important architectural heritage. Looking at today's energetically renovated building in Albertusstraße, it is lost in its architectural originality: All of the concrete has disappeared under a new multi-skinned façade. I stood helplessly in front of the renovated building. Was the new shell the only right and unavoidable step?

A university seminar offers the opportunity to follow up on this question retrospectively. The students analysed the different possibilities for providing improved thermal insulation individually and in steps. The results were new for the students but will hardly come as a surprise to an architect with experience in the field of energy.

- Insulating flat roof surfaces can be efficiently and comparatively easily realised without impacting the façade. Less efficient but just as easy to realise is insulating against the ground as an internal insulation or on the ceiling of an unheated basement. In the analysed example, these two steps yielded energy improvements of up to 15 percent.
- Depending on the glass quality, replacing the windows yields a further 15 to 25 percent and is the second important item.
- Both measures together yield up to 30 percent of energy savings. Complemented by a high-efficiency heating system, the power balance could be optimised up to 50 percent of savings.

In the social discussion on "climate protection", new buildings and also old buildings are expected to have a high insulation standard to reduce the heating energy need and

accordingly, to reduce the carbon footprint. The German directive on energy-efficiency, EnEV, implements this general consensus. At the same time, we make high aesthetic demands on architecture. In the public dialogue about building culture, this is not only limited to new buildings but also refers to old buildings. With the increasing use of façade insulation, however, streets are losing their face. The materials and workmanship that are typical for a city become invisible. The history of the houses, and with it an essential part of our architectural culture, disappears. Apart from the fact that the standard demanded for new buildings can be reduced by up to 40 percent for old buildings, EnEV permits no exceptions. A differentiated and holistic observation would counter the hasty application of the directive with an alternative. This will also create greater scope for us architects. With materials such as natural stone, bricks and concrete, one would have to take the permanence of the construction into consideration as well as the objectified resource that is "grey" energy. Basically, Sect. 25 EnEV admits exceptions if they constitute "unreasonable effort" or "undue hardship". It is unclear whether only financial arguments count as hardship according to EnEV or whether construction practice and cultural arguments can also be considered. When it comes to building stock, it is not possible to force a renovation. A house made from a maintenance-free facade material with a long remaining useful life would, if considered factually, not be covered with a comparatively short-lived insulation system. The many uninsulated old buildings show that house owners are following this logic. This refusal to insulate one's own home occurs despite all the programmes and financial incentives. Reaching the high proportion of unrenovated stock requires a flexible, undogmatic approach that will consider energetic, practical and cultural aspects in equal measure. For the valuable (worthy of conservation) building stock, the following individual measures are undisputed in their efficiency:

1. Increasing the insulation thickness above the highest heated floor (ceiling). This is not associated with any impairment of the façade.
2. Insulating structural elements that are worn anyway or only have a short remaining useful life (e.g. windows and glazed areas).
3. A simple internal insulation such as with mineral foam boards as an alternative to insulating the facade.
4. Using energy-efficient and environmentally-friendly heating systems.

This would save 30 to 50 percent of heating energy while conserving the historical architecture. With common sense and an appropriate building climate observation, considerable energy savings can be achieved without losing the original facade.

KONSTRUKTION TECHNOLOGIE

MATERIAL / DIGITALE VERFAHREN

**Ahmad Alsaied, Anita Bärish,
Shara Haues, Lisa-Madeline Petzold
Dmytro Safronov, Sophie Stiehl
Philipp Ullrich, Marija Vujovic**

Master Architektur SS 2018

Supervisors: Prof. Dr. Matthias Höhne,
Christian Pfützte

Energieeffiziente Architektur – Was ist uns unser architektonisches Erbe wert? *In Erinnerung an Erich*

Prof. Erich Schneider-Wessling, einer der bedeutenden Architekten Westdeutschlands, starb am 28. September 2017 in Köln. Mein Start in den Beruf begann 1989 in seinem Büro im *Bauturm*, einer Architektengemeinschaft, die er 1968 mit Peter Busmann gegründet hatte. Diese sehr prägenden Erfahrungen als junger und tatsächlich planender Architekt begleiten mich bis heute. Bei der Trauerfeier zu seiner Beerdigung wurde mit einer Bilderfolge noch einmal an seine Architektur aus drei Jahrzehnten erinnert. In dieser Werkreihe fielen mir besonders die Sichtbetonbauten auf. Betonraue Gebäude, wie etwa die Albertusstraße 18 in Köln, gehören für mich aus ostdeutscher Sicht zum wichtigen Architekturerbe Westdeutschlands. Betrachtet man heute den – inzwischen energetisch sanierten – Bau in der Albertusstraße, dann ist dieser in seiner architektonischen Ursprünglichkeit verloren: Der gesamte Beton ist unter einer neuen mehrschaligen Fassade verschwunden. Ratlos stand ich vor der Sanierung. War die neue Hülle der einzig richtige und alternativlose Schritt?

Ein Hochschulseminar bot die Chance, dieser Frage rückblickend nachzugehen. Die Studierenden untersuchten die unterschiedlichen Möglichkeiten einer verbesserten Wärmedämmung einzeln und in Schritten. Die Resultate waren für die Studierenden neu, werden jedoch einen energieerfahrenen Architekten kaum überraschen.

- Eine Dämmung der Flachdachflächen ist effizient und vergleichbar einfach ohne eine Beeinträchtigung der Fassaden umzusetzen. Weniger effizient, aber ebenso leicht realisierbar ist die Dämmung gegen Erdreich als Innendämmung oder an der Decke vom unbeheizten Keller. Im untersuchten Beispiel ergaben sich aus diesen beiden Schritten energetische Verbesserungen von bis zu 15 Prozent.
- Die Erneuerung der Fenster erbringt je nach Glasqualität weitere 15 bis 25 Prozent und ist der zweite wichtige Punkt.
- Beide Maßnahmen ergeben zusammen bis zu 30 Prozent Energieeinsparung. Mit einem hocheffizienten Heizsystem ergänzt, ließe sich die Energiebilanz bis auf 50 Prozent Einsparung optimieren.

In der gesellschaftlichen Diskussion zum »Klimaschutz« wird von Neubauten und ebenso von Altbauten ein hoher Dämmstandard zur Reduktion des Heizenergiebedarfs und entsprechend zur Verringerung der CO₂-Belastung erwartet. Die EnEV setzt diesen allgemeinen Konsens um. Zugleich stellen wir an die Architektur einen hohen ästhetischen Anspruch. Dieser beschränkt sich im öffentlichen Dialog über Baukultur nicht nur auf Neubauten, sondern bezieht auch die Altbauten ein. Mit den zunehmenden Fassadendämmungen verlieren die Straßen jedoch ihr Gesicht. Die für die Stadt typischen Materialien und handwerklichen Ausführungen werden unsichtbar. Es verschwindet die Geschichte der Häuser und damit ein wesentlicher Teil unserer architektonischen Kultur.

Abgesehen davon, dass bei Altbauten der für Neubauten geforderte Standard um 40 Prozent reduziert werden kann, lässt die EnEV keine Ausnahmen zu.

Eine differenzierte und ganzheitliche Betrachtung würde dem unreflektierten Anwenden der Verordnung eine Alternative entgegensetzen. Damit entsteht auch für uns Architekten ein größerer Spielraum. Bei Materialien wie Naturstein, Ziegel und Beton wäre die Dauerhaftigkeit der Konstruktion ebenso zu berücksichtigen wie die vergesamtete Ressource »graue« Energie.

Grundsätzlich lässt § 25 EnEV Ausnahmen als »unangemessener Aufwand« oder als »unbillige Härte« zu. Offen ist, ob nach EnEV nur finanzielle Argumente als Härte gelten oder ob ebenso baupraktische und kulturelle Argumente berücksichtigt werden können.

Im Gebäudebestand kann eine Sanierung nicht erzwungen werden. Ein Haus aus einem wartungsfreien Fassadenmaterial mit einer hohen Restnutzungszeit würde bei sachlicher Abwägung nicht mit einem vergleichsweise kurzlebigen Dämmsystem überzogen werden. An den vielen ungedämmten Altbauten zeigt sich, dass Hausbesitzer dieser Logik folgen. Diese Verweigerung, das eigene Haus zu dämmen, findet trotz aller Programme und finanzieller Anreize statt. Will man den großen unsanierten Bestand erreichen, ist ein flexibles, undogmatisches Herangehen erforderlich, um energetische, praktische und kulturelle Aspekte gleichermaßen zu berücksichtigen. Für den wertvollen (erhaltenswerten) Gebäudebestand sind folgende Einzelmaßnahmen in ihrer Effizienz unstrittig:

1. Erhöhung der Dämmstärke über der obersten beheizten Geschossdecke (Dach). Damit ist keine Beeinträchtigung der Fassade verbunden.
2. Dämmung von Bauteilen, die ohnehin verschlissen sind oder die nur noch eine geringe Restnutzungsdauer haben (z. B. Fenster und Verglasungen).
3. Eine einfache Innendämmung, zum Beispiel mit Mineralschaumplatten, als Alternative zum Dämmen der Fassade.
4. Einsatz energieeffizienter und umweltfreundlicher Heizsysteme.

Damit könnten 30 bis 50 Prozent Heizenergie bei gleichzeitigem Erhalt der historischen Architektur eingespart werden. Mit gesundem Menschenverstand und mit einer angemessenen bauklimatischen Betrachtung sind erhebliche energetische Einsparungen erreichbar, ohne die originalen Fassaden zu verlieren.

Bachelor- studiengang

Bachelor

Degree Programme



BIBLIOTHEK MIT WERKATELIERS
 DIE SCHLEIERMACHER-HÄUSER,
 BERLIN-MITTE

Julian Faro Teichert
 Architektur Bachelor Thesis SS 2019
 Supervisors: Prof. Dr. Natascha Meuser,
 Prof. Andreas Theurer

Das Schleiermacherhaus in Berlin ist eines der letzten verbliebenen Barockensembles der historischen Friedrichstadt. Der ursprünglich aus drei Gebäuden bestehende Komplex entstand 1738 im Zuge der Errichtung der Dreifaltigkeitskirche für deren Prediger. Prominentester Bewohner war 1809–1816 der Philosoph, Theologe und Mitbegründer der Berliner Universität Friedrich Schleiermacher. Nach 1945 wurde eines der drei Häuser nach einem Brand abgerissen. Bis jetzt ist diese Lücke frei. Ziel des Entwurfs ist eine sensible Ergänzung des denkmalgeschützten Bestands mit neuer Nutzung. Der Entwurf gliedert sich in ein Vorderhaus und einen modernen Anbau im Innenhof. Das Vorderhaus schließt die Lücke und übernimmt gestalterische Elemente der Barockbauten. Der Baukörper im Innenhof ist ein leicht anmutender Glaspavillon, der die Fassaden und die Grünflächen der Bestandsgebäude spiegelt. Alle vier Außenwände sind völlig transparent und werden an den Längsseiten von jeweils zwei Stützen unterbrochen.



Schnitt

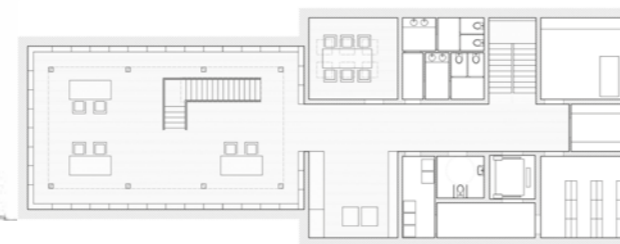

Untergeschoss

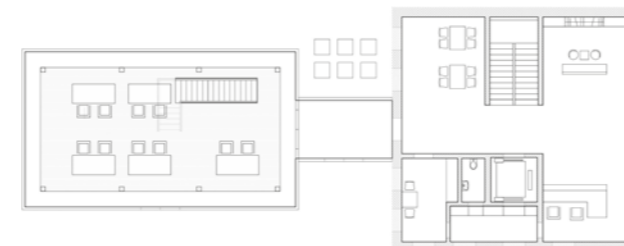

Erdgeschoss

Dachgeschoss



Perspektive Glaspavillon

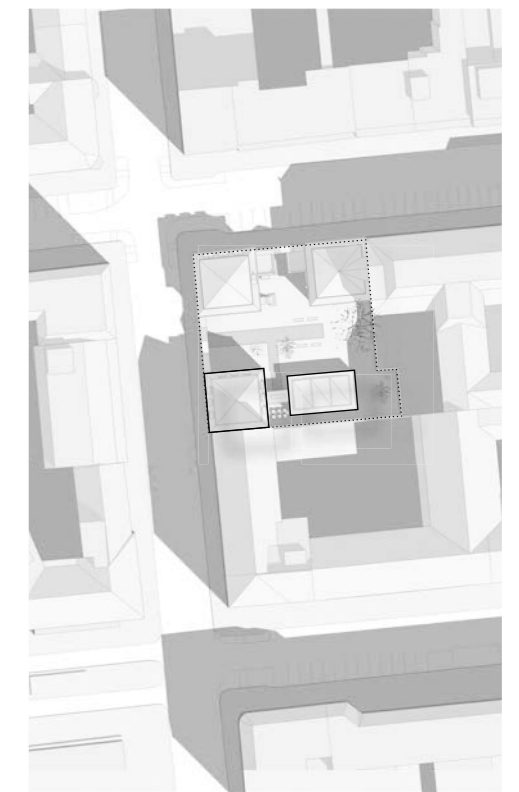

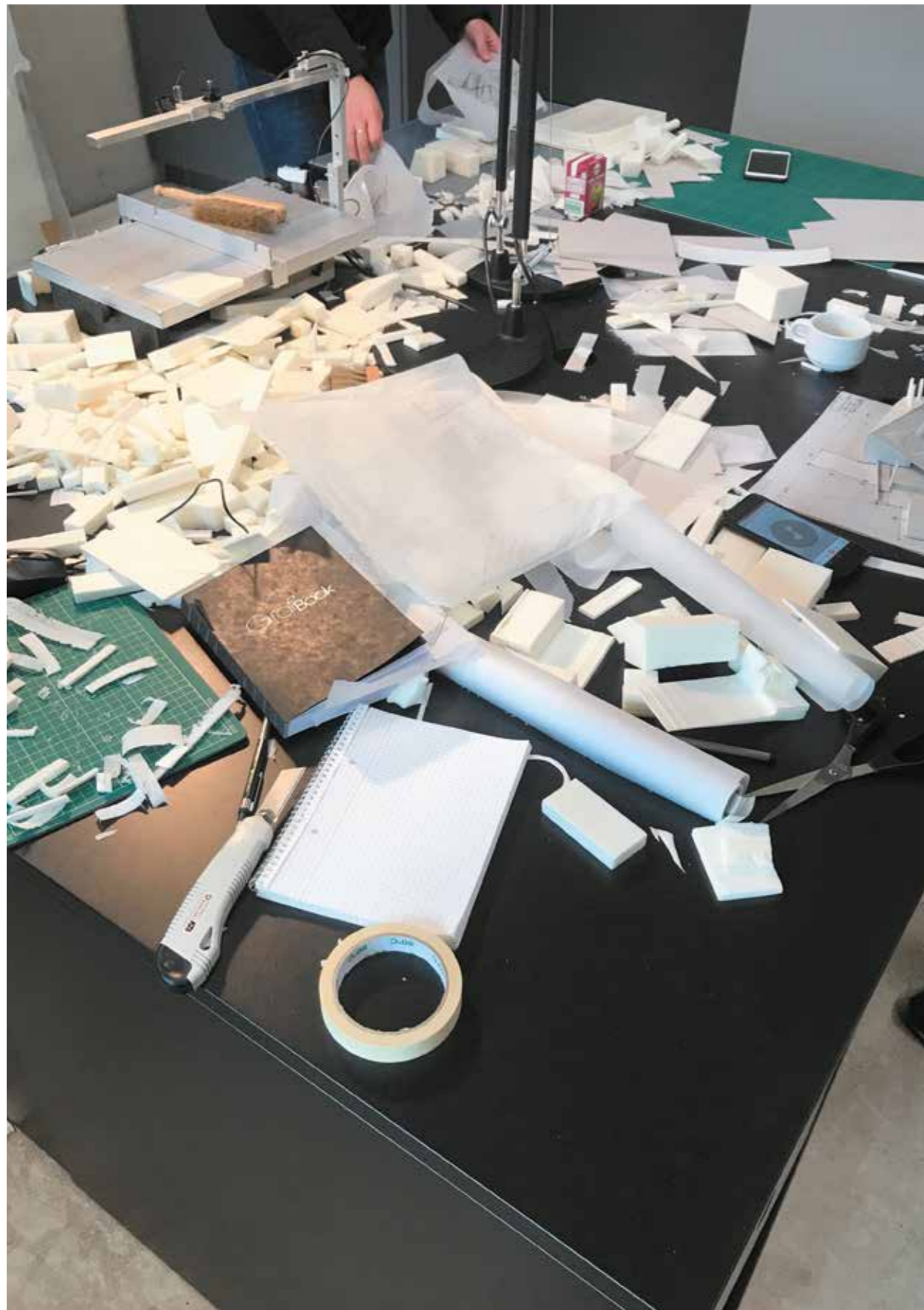

STUDIO KISTER
MASTER ARCHITEKTUR

Das Studio entwickelt städtebaulich architektonische Lösungen aus einer intensiven Arbeit am Modell. Themen finden sich vorzugsweise in Berlin und beginnen mit einem Umgebungsmodell. Grundprinzip des Studios ist das Entwickeln des Entwurfs mittels dreidimensionalen handwerklichen Arbeitens am Modell – vor allem auch durch das programmatische Aufladen der Funktion. Mit dieser Arbeitsmethode lassen sich Konzepte generieren, die kaum auf zeichnerischem, zweidimensionalem Weg entwickelt werden könnten. Das ausgewählte Modell in seinem städtebaulichen Kontext bildet die Leitidee für eine spätere Ausarbeitung.



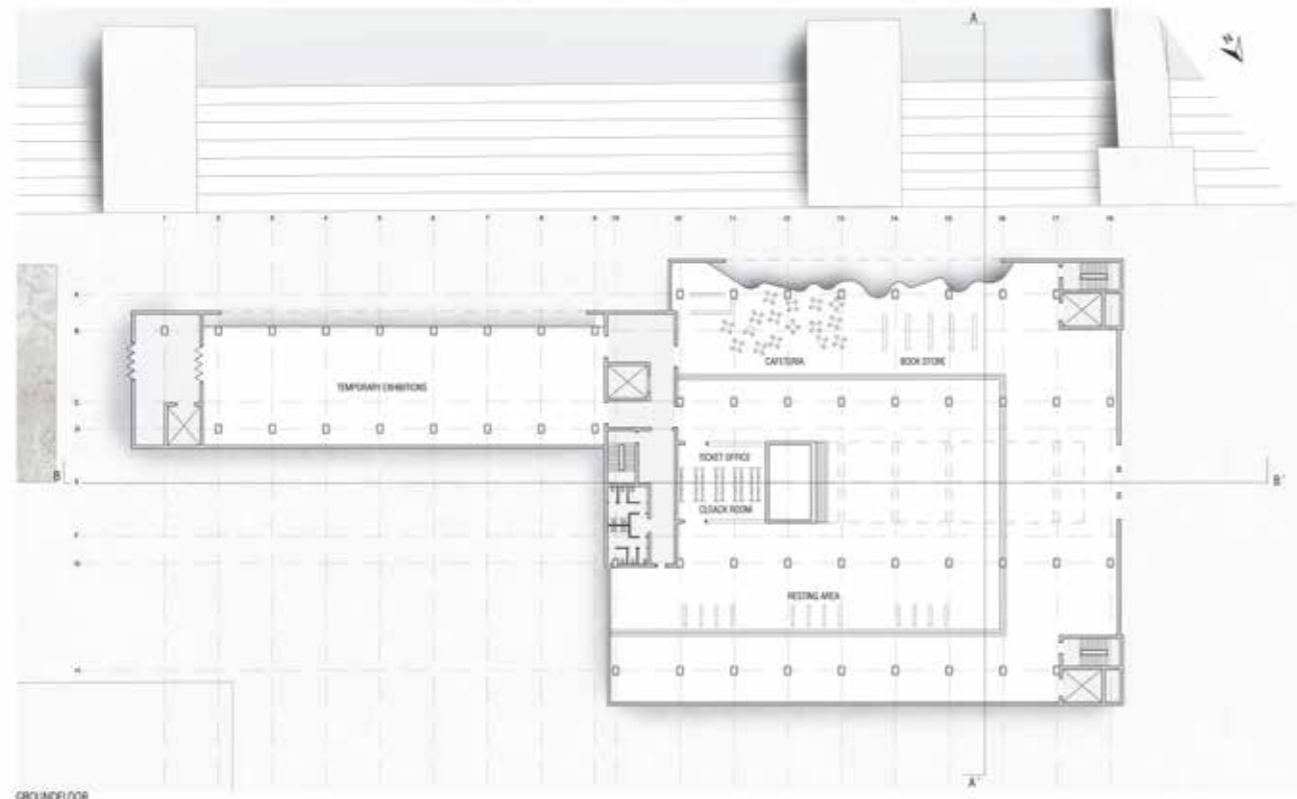

GROUND FLOOR
1:200



SECTION AA

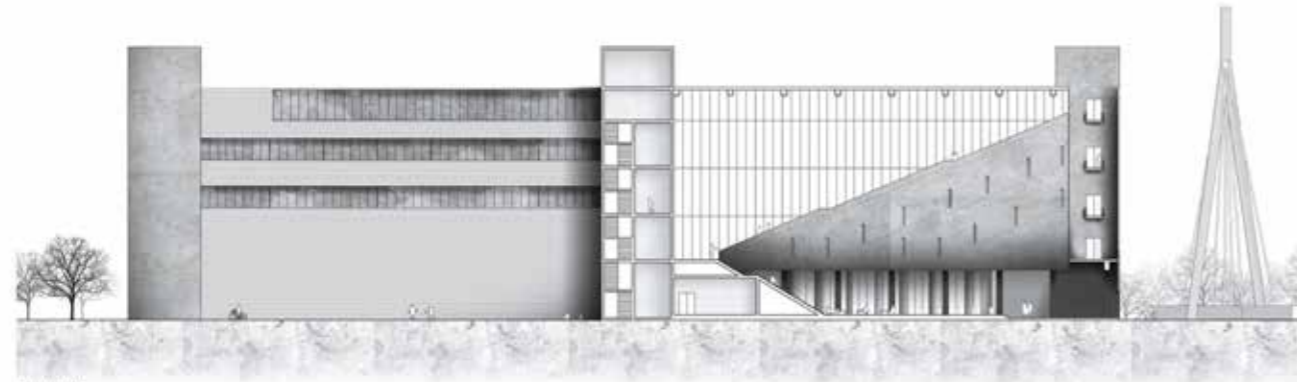

CANALE GRANDE
BERLIN-OBERSCHÖNEWEIDE

Silvia Amor Rivas
Architektur Bachelor Studio SS 2018
Supervisors: Prof. Johannes Kister,
Prof. Mia Roth-Ćerina, Cornelia Böttner

Die großen Industriebauten der Zwanzigerjahre entlang der Spree in Berlin-Oberschönevide stehen zum Teil leer und können neu interpretiert werden. Aufgabe war es, einen Masterplan zur Umnutzung zu entwerfen und ein Bauwerk, das einst für die Kunststoffproduktion genutzt wurde, für neue Nutzungen zu untersuchen. Unterschiedliche Ansätze haben ergeben, dass die Struktur sehr gut für eine Vielzahl von Nutzungen geeignet ist.



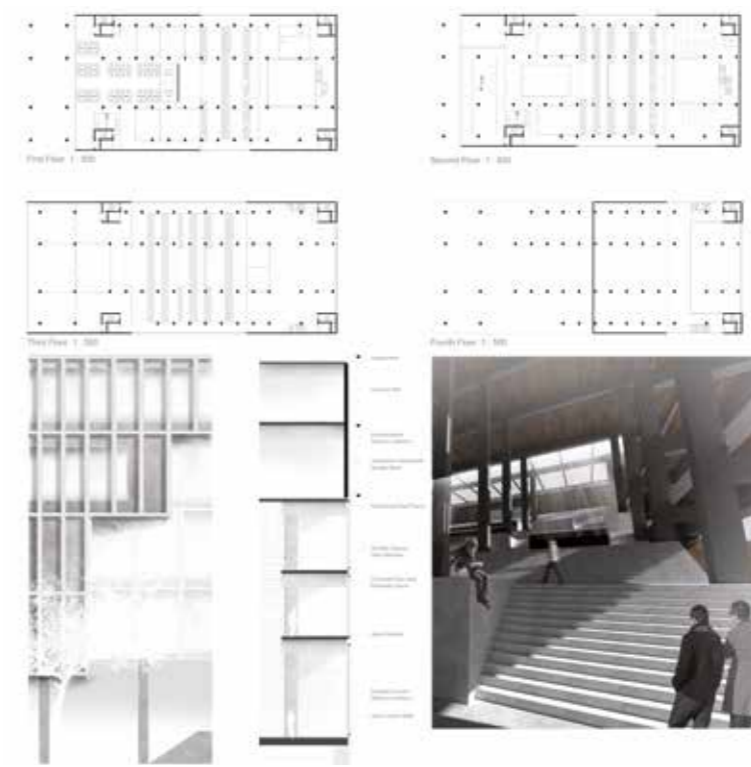
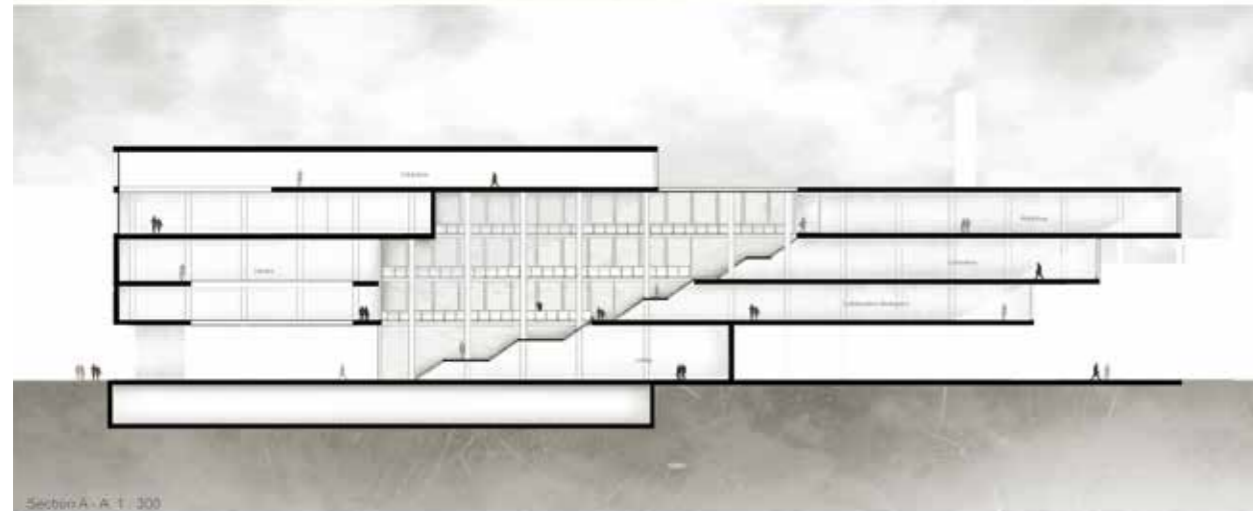
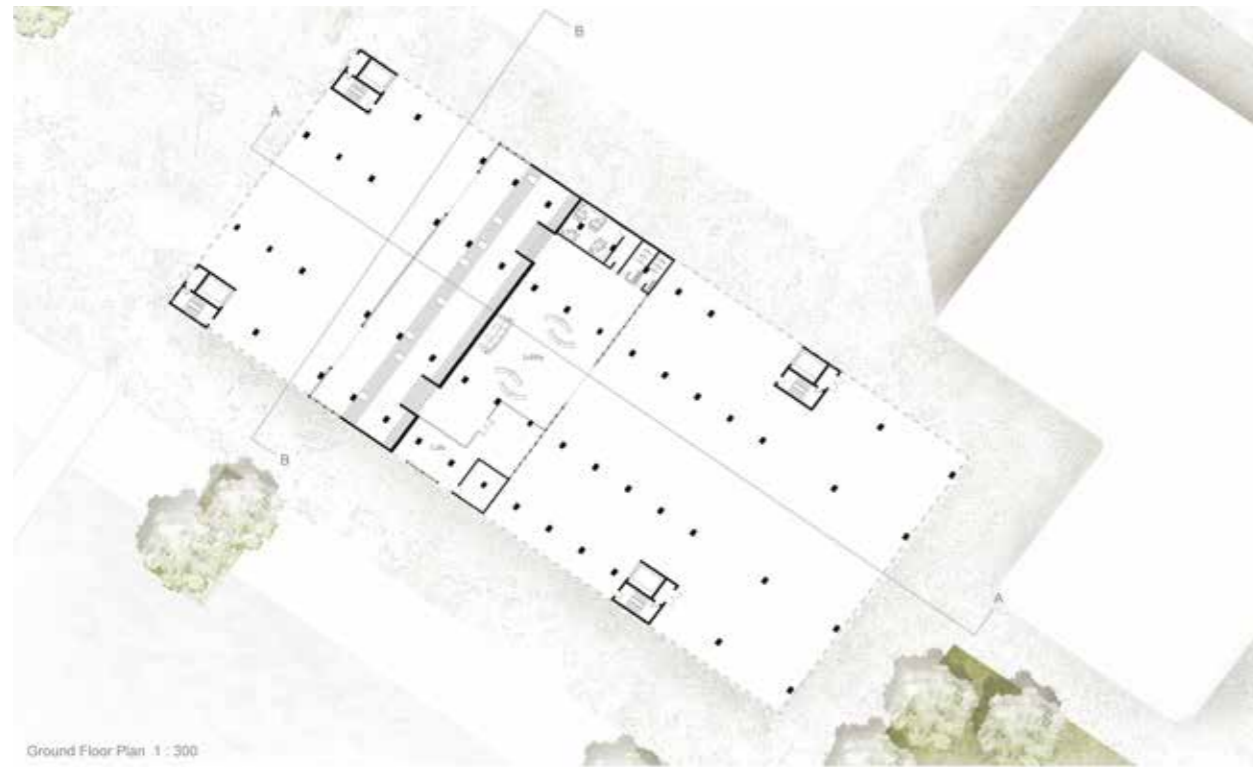

CANALE GRANDE
 BERLIN-OBERSCHÖNEWEIDE

Imran Suhaimi bin Muhammad Ali
 Architektur DIA Studio SS 2018
 Supervisors: Prof. Johannes Kister,
 Prof. Mia Roth-Cerina, Cornelia Böttner



Canale Grande

Proposing a manufactured and production office to revitalize the mechanical aspect that has been non-functioning for time to time. Rejuvenate and reutilize the structure of the form, structure, utilization by extend the form to fit in the program purposes. Expressing the innovative nature of the green research and manufacturing sector and preserving the structure of the great historic factory relation. Providing sustainable services such as 3D Print, Laser Cut, Robotics Lab and manufacturing method.

Seamless step office sandwiched between public lobby with waiting and shade as part of the layer. Allowing potential public shape within the building and expanding the meaning of building to create possibility of perspective spaces having custom as terrace allowing solid and light into the building to connect a uniform line of space and programme essentially, that allowing visual communication of opportunity outside and inside complementing the river beauty.





CANALE GRANDE
BERLIN-OBERSCHÖNEWEIDE

Tina Witthohn
Architektur Bachelor SS 2018
Supervisors: Prof. Johannes Kister,
Prof. Mia Roth-Cerina, Cornelia Böttner

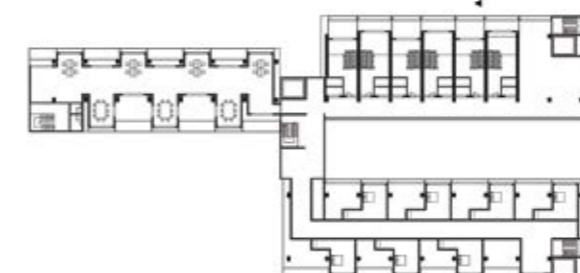
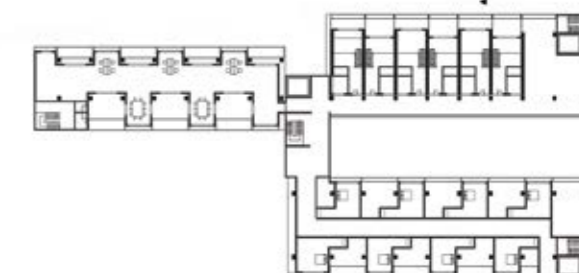
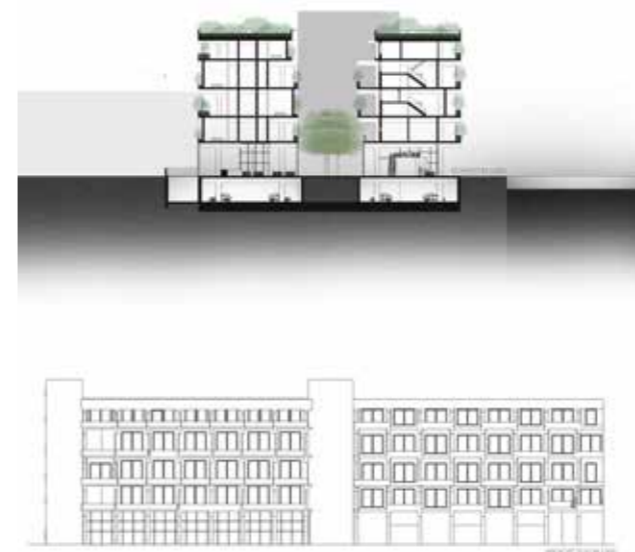

Die Gegend der Kabelwerke in Oberschöneeweide befindet sich schon seit langem im Wandel. Eine times Industriegebiet, das als solches nicht mehr genutzt wird. Zwar existieren noch wie vor industrielle Nutzungen, allerdings nehmen sie nicht mehr den Hauptbestandteil ein. Die HTW hat einen neuen Sitz hier gefunden, außerdem haben sich in den Reinbeckhallen Abellers angesiedelt. Die zeitgemäße Industrie heißt anscheinend Kultur und Bildung und ist besser kompatibel mit Residieren und Wohnen.

Die Ausgangsfrage nach den Nutzungsmöglichkeiten kann vielseitig beantwortet werden. Eine Mischung aus Wohnen, Hotel, Arbeiten, Gastronomie und Fachgeschäften ist gut vorstellbar.

Alte und neue Gebäudesubstanz haben einen unterschiedlichen Charakter, verstärkt durch ihre Gegensätzlichkeit, ihre Wirkung. Daher ist eine Reihe kleinere Gebäude in das große Tragwerk eingebracht.

So ist gleichzeitig die Frage nach Wärmeschutz und Sichtbarkeit der alten Struktur beantwortet.

Auch in der Materialität sollen Kleinteiligkeit und Lebendigkeit durch Materialität unterstrichen werden, ein Klinker bietet sich dazu an.

Die Lebendigkeit im Gegensatz zur Festigkeit des mächtigen Tragwerks wird nicht zuletzt herausgestellt durch eine extensive Begrünung aller offenen Flächen. Außerdem dienen die Bepflanzungen als Ausgleichsfächen zu der Versiegelung der Umgebung. Sie dienen auch als sommerlicher Wärmeschutz und als Sichtschutz.

Der Innenraum des Gebäudes hat eine starke Beziehung zum Außenraum. In regelmäßigen Abständen entstehen begrünte, betretbare Außenzonen. Das erhöht die Nutzungsqualität des Gebäudes. Urbanität und Natur nähern sich an.

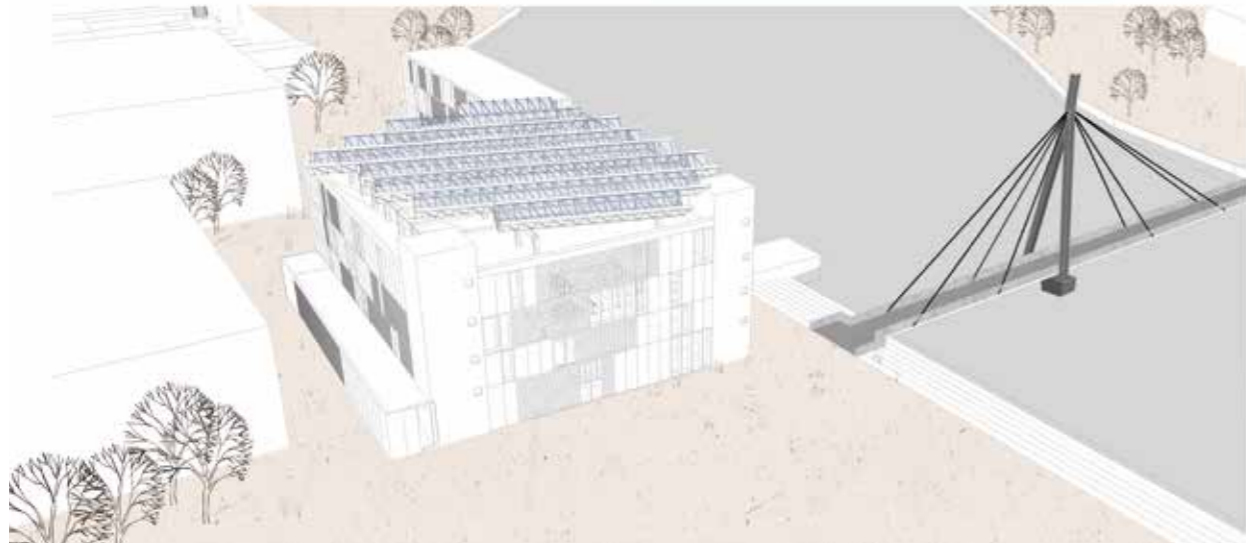

CANALE GRANDE
BERLIN-OBERSCHÖNEWEIDE

Chen Yuanyuan
Architektur Bachelor SS 2018
Supervisors: Prof. Johannes Kister,
Prof. Mia Roth-Čerina, Cornelia Böttner

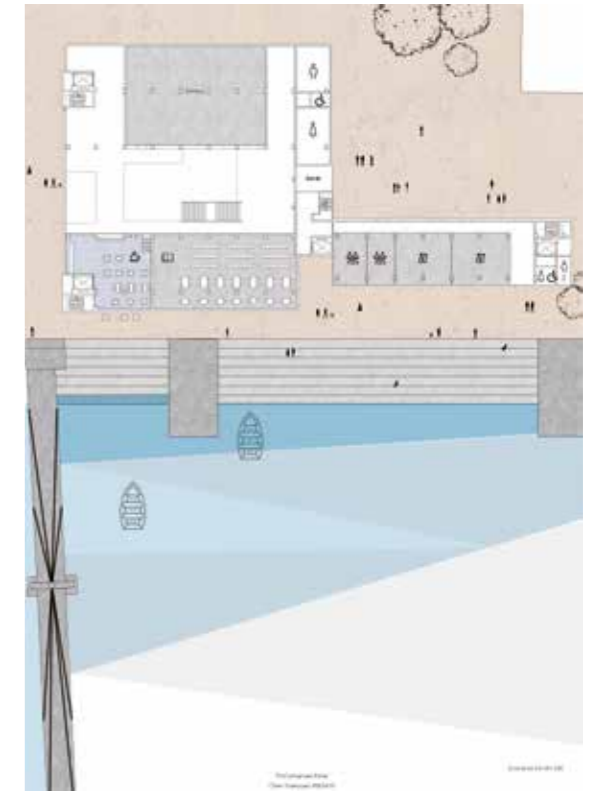

DRAWING FOR ARCHITECTS
COLORATURA

Architektur Bachelor Studio WS 2018/19
 DIA Architecture Studio WS 2018/19
 Supervisors: Prof. Johannes Kister,
 Christoph Mathys, Cornelia Böttner

Colorierung mit Ölkreiden. Diese Methode der Architekturdarstellung ist eine an der ETH Zürich erprobte Technik. Sie wurde den Studierenden in einem Workshop vermittelt unter Anleitung von Christoph Mathys, Architekt und langjähriger Assistent am Lehrstuhl von Miroslav Šik.



Christoph Mathys demonstriert den Studierenden die Zeichentechnik.
 Fotos: Anja Müller



Josephin Latha Ashish Varshith



Shubham Jain



Elena Erichsen



Sejla Gruda

Projekte
 Student Projects

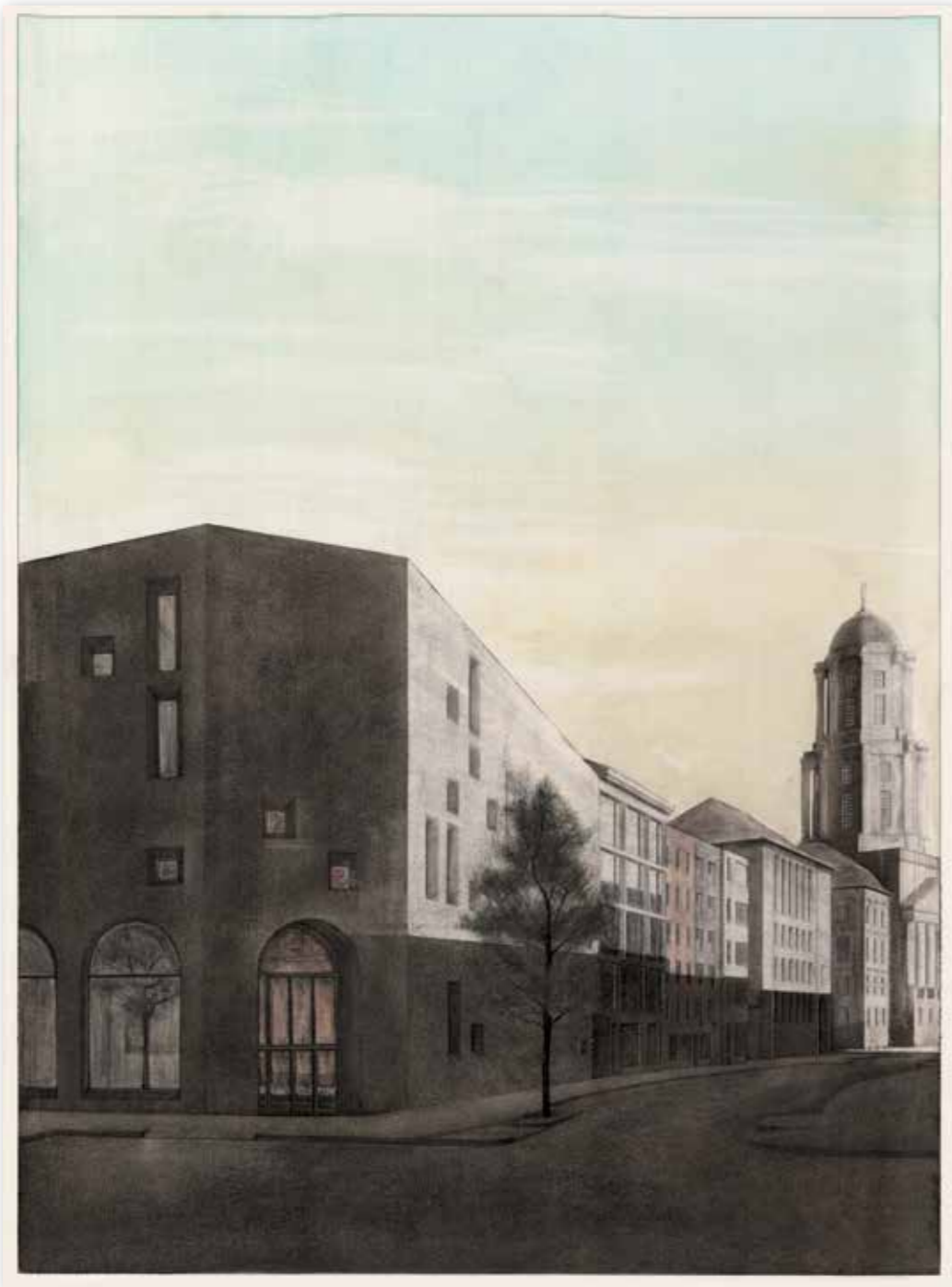

Seraina Bernegger



Chen Yuanyuan



Bruno Baumgardt



Rujia Tang



Liu Jinxin

ERGEBNISSE GRUNDLAGEN DER GESTALTUNG, 1. SEM., 1AR, FOYER HAUS 15, PROF. C.C. WEBER



„...und der Raum selbst: eine Gerade von jedem Punkt zu jedem, von diesem Dach zu dieser Wolke, zur Sonne, zum Dach zurück. Aus Punkten Linien, aus Linien Flächen und aus Flächen Körper, doch damit war es nicht getan. Seine feine Biegung, von hier oben war sie fast zu sehen.“

Die Vermessung der Welt, 2005
Daniel Kehlman

**PUNKT ZU FLÄCHE, FLÄCHE ZU RAUM
RAUM ZU RÄUMLICHER FLÄCHE**

Keramik:
Mark Philipp Darius Brehm

Puppe:
Mengyuan Huang

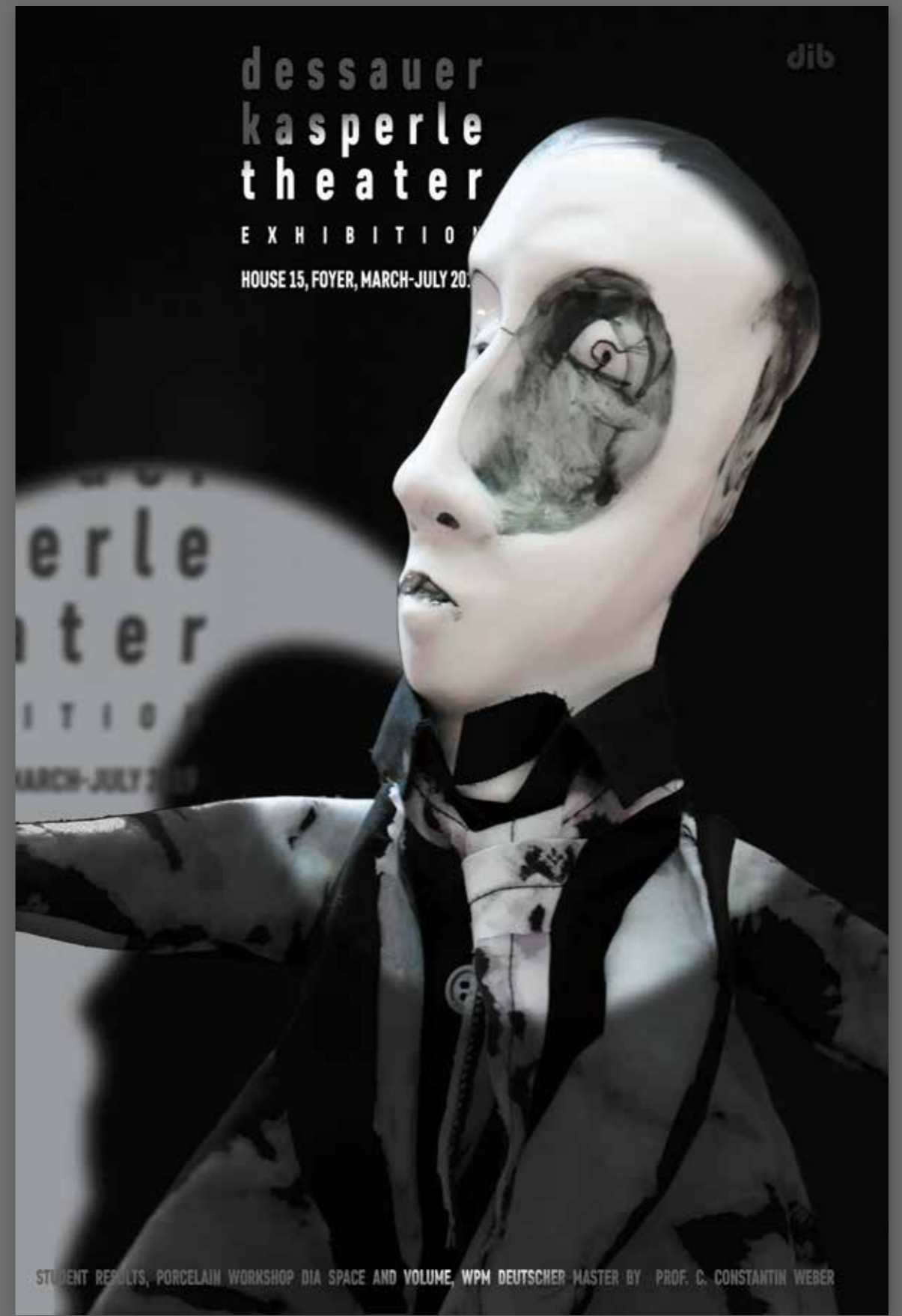

dessauer
kasperle
theater
EXHIBITION
HOUSE 15, FOYER, MARCH-JULY 2019

dib

STUDENT RESULTS, PORCELAIN WORKSHOP DIA SPACE AND VOLUME, WPM DEUTSCHER MASTER BY PROF. C. CONSTANTIN WEBER

PORZELLAN
EXHIBITION POSTER DIA/MA ARCH WS 2019
Supervisor: Prof. Carl Constantin Weber

GRUNDLAGEN DER GESTALTUNG
EXHIBITION POSTER BA ARCH WS 2019
Supervisor: Prof. Carl Constantin Weber

PLASTISCHES GESTALTEN
FORM UND VERFORMUNG

Architektur Bachelor 2018/19
 Supervisors: Prof. Andreas Theurer,
 Tino Ahlmann

Fotos: Tino Ahlmann
 rechte Seite (Reihe von links nach rechts)

- 1 **Natascha John, Liu Lixian,
 Lydia Johannemann**
- 2 **Juliane Schmidt, Luise Katharina Thaler,
 Jean Guillaume Veilleux**
- 3 **Kai-Joseph Engbers, Manuel Sebastian
 Haselwander, Qianqian Li**
- 4 **Marie Spier, Yuqin Shang,
 Thien Huong Pham**
- 5 **Jan Struck, Manuel Marx,
 Nico Feldmann**
- 6 **Sarah Kehrle, Lu Chiao,
 Ralf-Marcus Mihai**

Schaumstoffmodell

Ein rechteckig geschnittener Kubus aus Schaumstoff wird durch Klammern, Einschnüren oder polsterartiges Heften verformt. Alle ebenen Flächen wandeln sich dabei zu konvex oder konkav gekrümmten Flächen mit fließendem Spannungsverlauf. Das Krümmungsverhalten ist nicht zufällig – es folgt physikalischen Gesetzmäßigkeiten.

Tonplastik

Keramischer Ton wird flächig ausgewalzt. Nach dem Vorbild des Schaumstoffmodells wird aus einzelnen Teilflächen ein zunächst vereinfachter hohler Volumenkörper erstellt. Anschließend werden die Flächen nach und nach gekrümmt, gewölbt und verformt, bis die plastische Spannung des Tonkörpers der des Schaumstoffmodells entspricht. Aus handwerklichen Gründen sollte die Deckfläche während des Formens nie ganz geschlossen sein, damit die Tonwandung auch von innen gewölbt und gehoben werden kann.

Keramik

Nach vollständiger Trocknung wird die Tonplastik gebrannt, dann glasiert oder bemalt.



PLASTISCHES GESTALTEN

KOMPOSITION I

Architektur Bachelor SS 2018
Supervisors: Prof. Andreas Theurer,
Tino Ahlmann

Fotos: Tino Ahlmann
unten

Sarah Kerle

rechte Seite (Reihe von links nach rechts)

1 Lydia Johannemann,
Jean Guillaume Veilleux

2 Kai-Joseph Engbers, Jeanesty Ginting,

3 Juliane Schmidt, Manuel Haselwander,

4 Ziqiang Zhu

Fließende Bewegung durch Verdichtung und Lockerung

Fünf oder sieben Kuben gleicher Größe und gleicher Richtung sollen so ineinander geschoben werden, dass ein kontinuierlicher Übergang von höchster Dichte zur leichten, räumlichen Durchdringung entsteht. Zum Beispiel können sich drei verdichtete Kuben einen Großteil ihres Volumens teilen, während auf der anderen Seite ein nahezu frei stehender Kubus entsteht. Die Kubenkomposition soll auf eine starke Sockelplatte montiert werden, die als Teil der Komposition anzusehen ist. Die Maße der Verschiebung und der Durchdringung sollen sich nicht sprunghaft, sondern fließend verändern. Jegliche Maßgleichheit, auch die einer diagonalen Anordnung, ist zu vermeiden. Zunächst wird ein skizzenhaftes Handmodell aus Ton erstellt, das im Unterricht besprochen wird. Die Ausführung des Objekts erfolgt wahlweise durch Fügen von Flächen, durch Schichten oder durch massives Material.

Materialien

Hohlform: Pappe, Balsaholz, Holzfurnier

Schichtung: Pappe, Holz, Sperrholz

Massiv: weiches Vollholz

Format

Höhe, Breite, Tiefe max. 30 Zentimeter

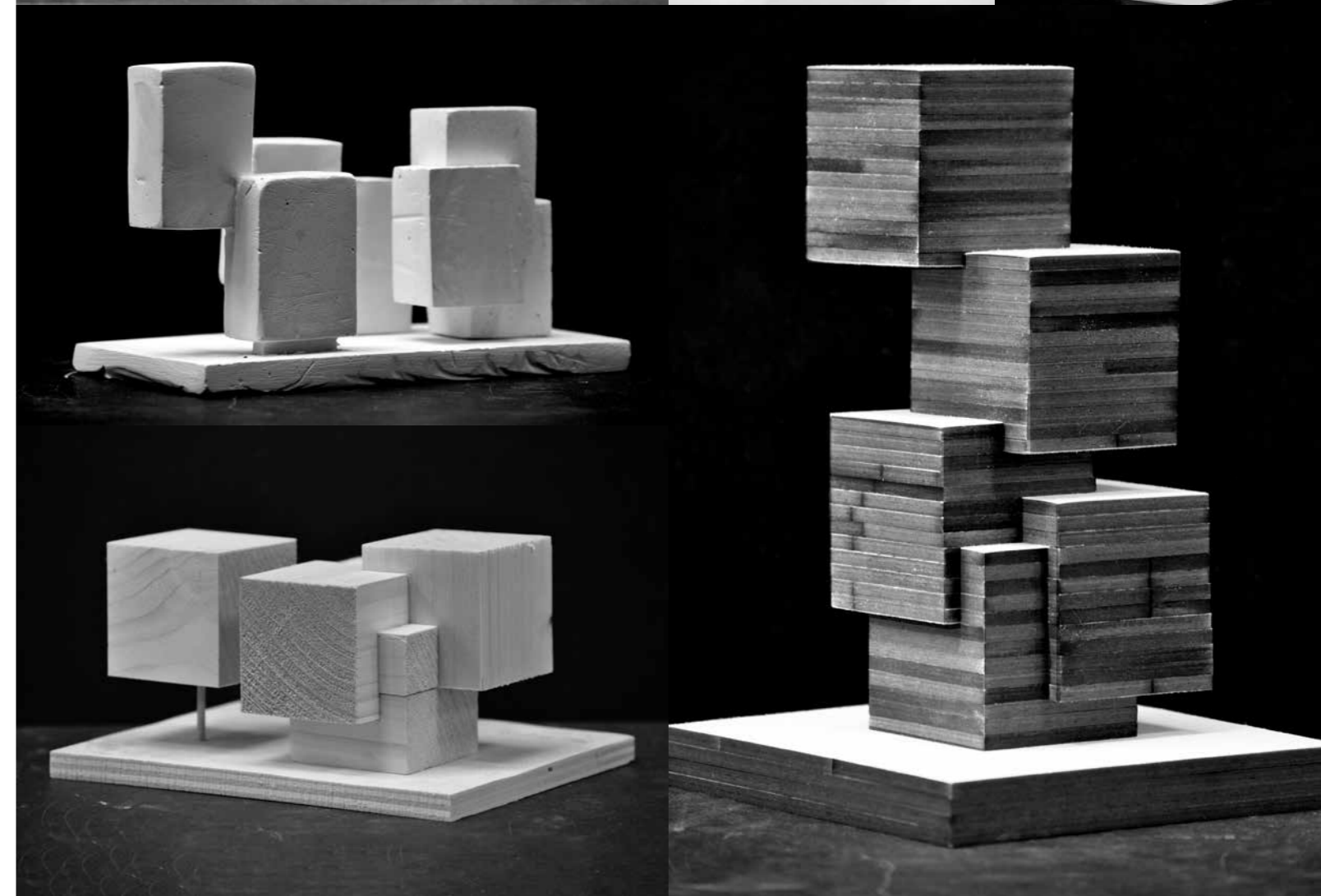

PLASTISCHES GESTALTEN

KOMPOSITION II

Architektur Bachelor WS 2018/19
Supervisors: Prof. Andreas Theurer,
Tino Ahlmann

Fotos: Tino Ahlmann
unten

Manuel Marx

rechte Seite (Reihe von links nach rechts)

1 Kai-Joseph Engbers, Juliane Schmidt

2 Jean Guillaume Veilleux

3 Luise Katharina Thaler, Lu Qiao

Antagonistische Bewegung, Verdichtung und Lockerung

Neun Kuben sollen so arrangiert werden, dass drei Gruppen von Kuben entstehen, die den Eindruck einer gegeneinander gerichteten, also einer antagonistischen Bewegung vermitteln. Da sich die Gruppen hinsichtlich Größe, Richtung und Dichte unterscheiden, entstehen klare Gruppengrenzen. Innerhalb der einzelnen Gruppen sind kontrastarme, fließende Übergänge zu suchen. Zwischen den drei Gruppen bestehen dagegen kontrastreiche Übergänge. Diese sind für den Eindruck der Gegenbewegung verantwortlich. Jegliche Maßgleichheit, auch die einer diagonalen Anordnung, ist zu vermeiden. Zunächst wird ein skizzenhaftes Handmodell aus Ton erstellt, das im Unterricht besprochen wird.

Die Ausführung des Objekts kann wahlweise durch Fügen von Flächen, durch Schichten oder durch massives Material erfolgen.

Material

Hohlform: Pappe, Balsaholz, Holzfurnier

Schichtung: Pappe, Holz, Sperrholz

Massiv: weiches Vollholz

Format

Höhe, Breite, Tiefe max. 30 Zentimeter



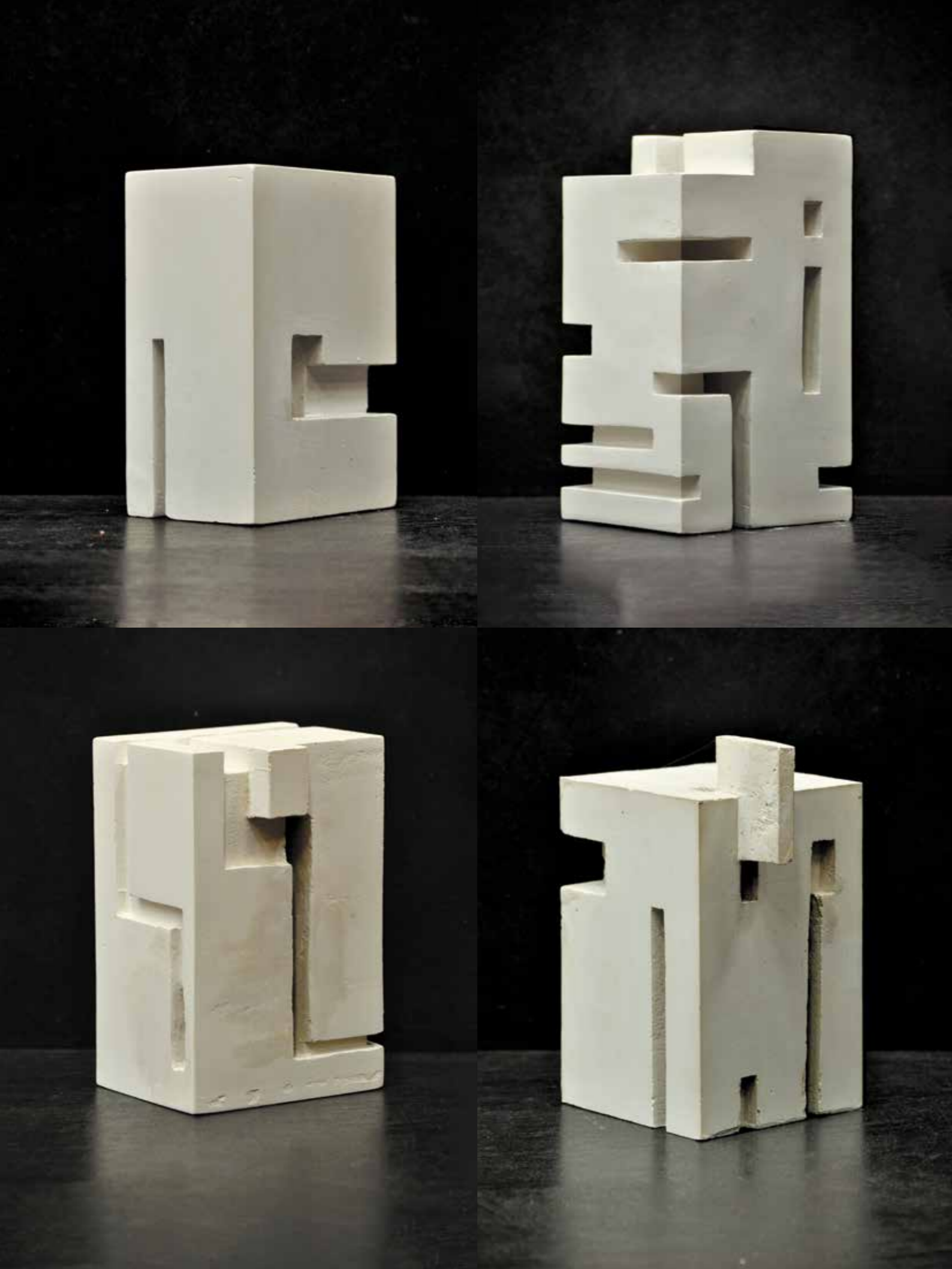

PLASTISCHES GESTALTEN

KOMPOSITION III

Architektur Bachelor WS 2018/19
Supervisors: Prof. Andreas Theurer,
Tino Ahlmann

Fotos: Tino Ahlmann
unten

Manuel Marx

rechte Seite (Reihe von links nach rechts)

1 Natascha John, Jeanesty Ginting

2 Manuel Haselwander,
Lydia Johannemann

Raum im Körper

Ausgangspunkt der Übung ist ein massiver Körper. Aus diesem werden Teile herausgeschnitten. Es entstehen Hohlformen, die Räume verschiedener Größe, Proportion und Dichte bilden mit jeweils unterschiedlichem Grad an Geschlossenheit bzw. Offenheit. Der subtraktive Vorgang des Aushöhlens darf nur so weit betrieben werden, dass der Gestalt- bzw. Massecharakter des Ausgangskörpers spürbar erhalten bleibt. Die Räume werden untereinander zu einem zusammenhängenden Raumgefüge verbunden. Dabei werden alle graduellen Abstufungen möglicher Raumbeziehungen genutzt. Diese liegen zwischen den Extremen ineinanderfließender Raumbereiche und voneinander separierter, autonomer Räume mit minimalster Anbindung.

Der zu erfindende Raumkörper ist ein zweckfreies, maßstabsloses räumliches Objekt ohne Untergrund. Er unterliegt in seiner Gesamtheit der Rechtwinkligkeit. Diese Übung erfordert eine Auseinandersetzung mit sehr komplexen Kompositionsprinzipien. Entsprechende Gestaltungskriterien werden in Vorlesungen und Praktika vermittelt.

Material

Die Übung kann wahlweise in drei unterschiedlichen Techniken ausgeführt werden. Alle Techniken setzen ein detailliert ausgearbeitetes Tonmodell voraus.



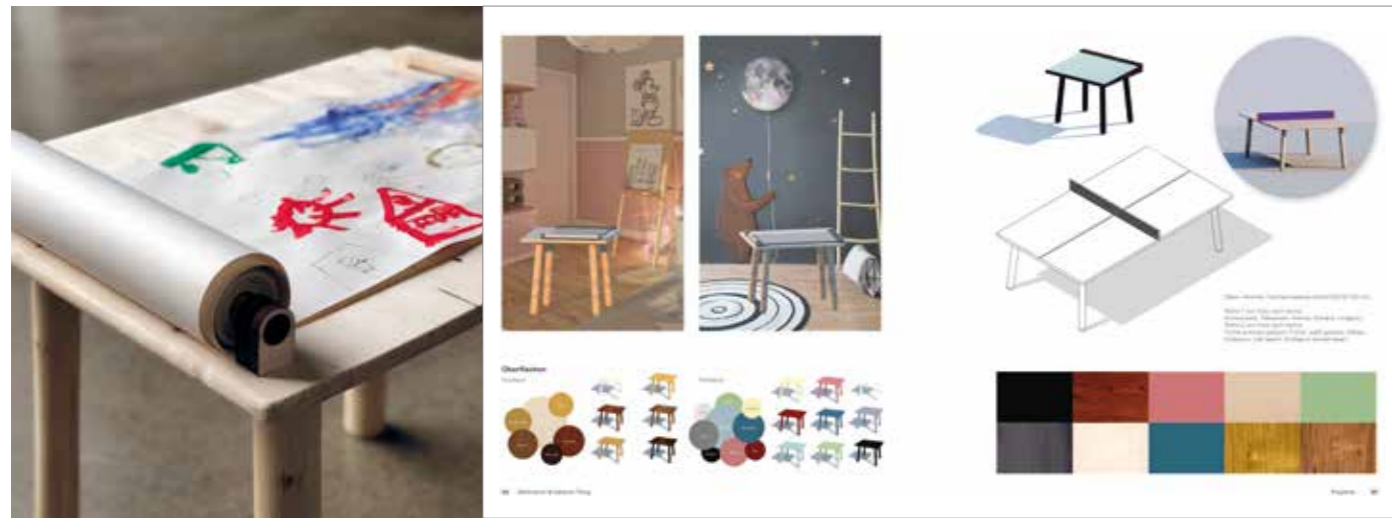

Praktisch: Vom Melkschemel zum Multi-Task-Schemel.
Sarah Bellmann, Angelina Kraetsch, Rujia Tang



MULTI_box.
Seraina Bernegger

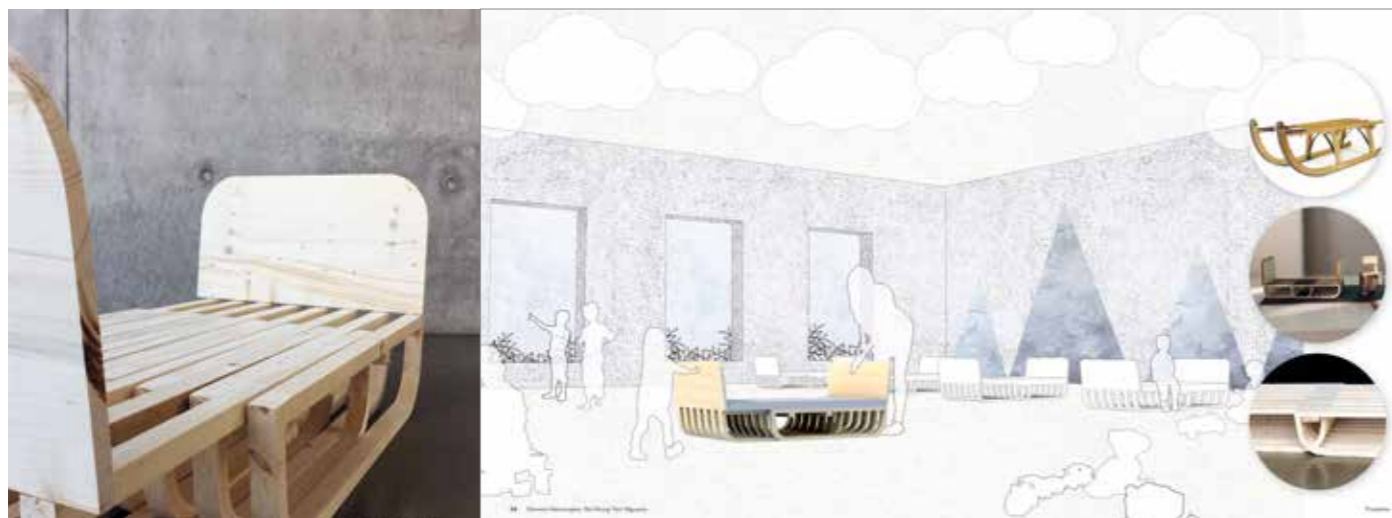

GROWING BED. Das mitwachsende Bett.
Dennis Henniges und Nu Hong Yen Nguyen

MÖBEL FÜR KINDER STUHL, SCHRANK, BETT UND TISCH

Architektur Bachelor WPM WS 2018/19
Supervisors: Prof. Dr. Natascha Meuser,
Quangduc Nguyen

Ziel der Lehrveranstaltung war es, durch die kulturgeschichtliche Entwicklung der Kindermöbel zu führen, Gestaltungsaufgaben zu definieren und Qualitätsstandards zu formulieren. In Form eines lehrenden Forschens wurden Planungsparameter erarbeitet, die es abschließend in einen konkreten Möbelentwurf umzusetzen und darzustellen galt. Die Studierenden bauten die Möbel als Prototypen in den Werkstätten auf dem Hochschulcampus. Dabei handelte es sich um die Holz- und Kunststoffwerkstatt sowie um das Robotiklabor.



Zauberwürfel. Vom Tisch zum Schrank.
Tingting Wu und Lingyue Zhao

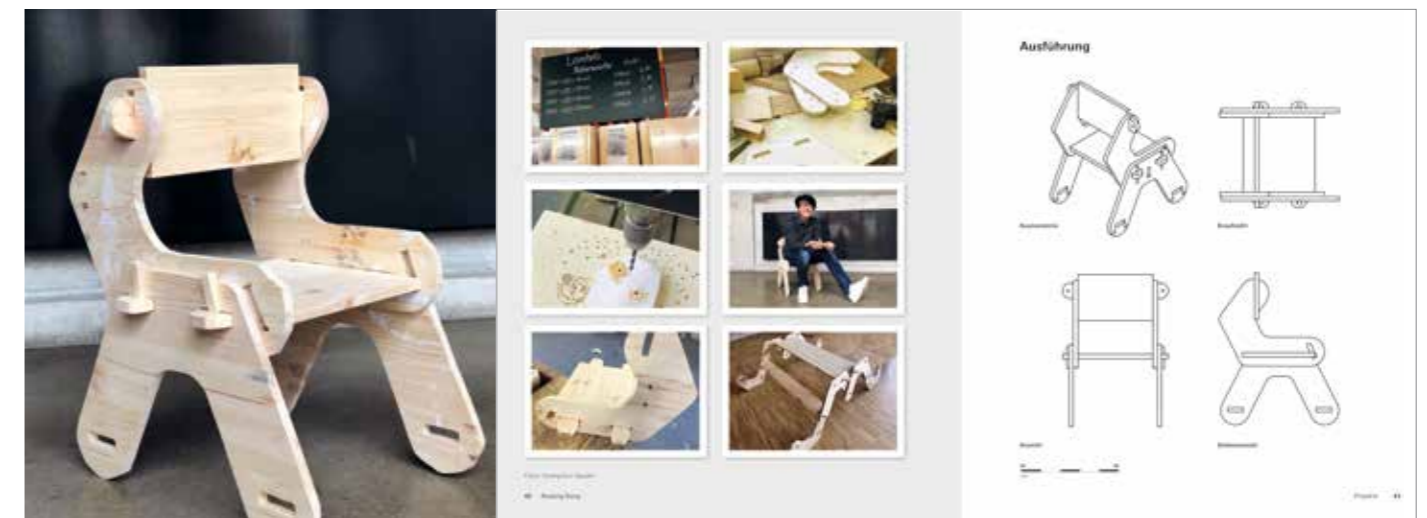

Puppy_Wood. Das Spiel von Stecken und Fügen.
Ruiqing Song

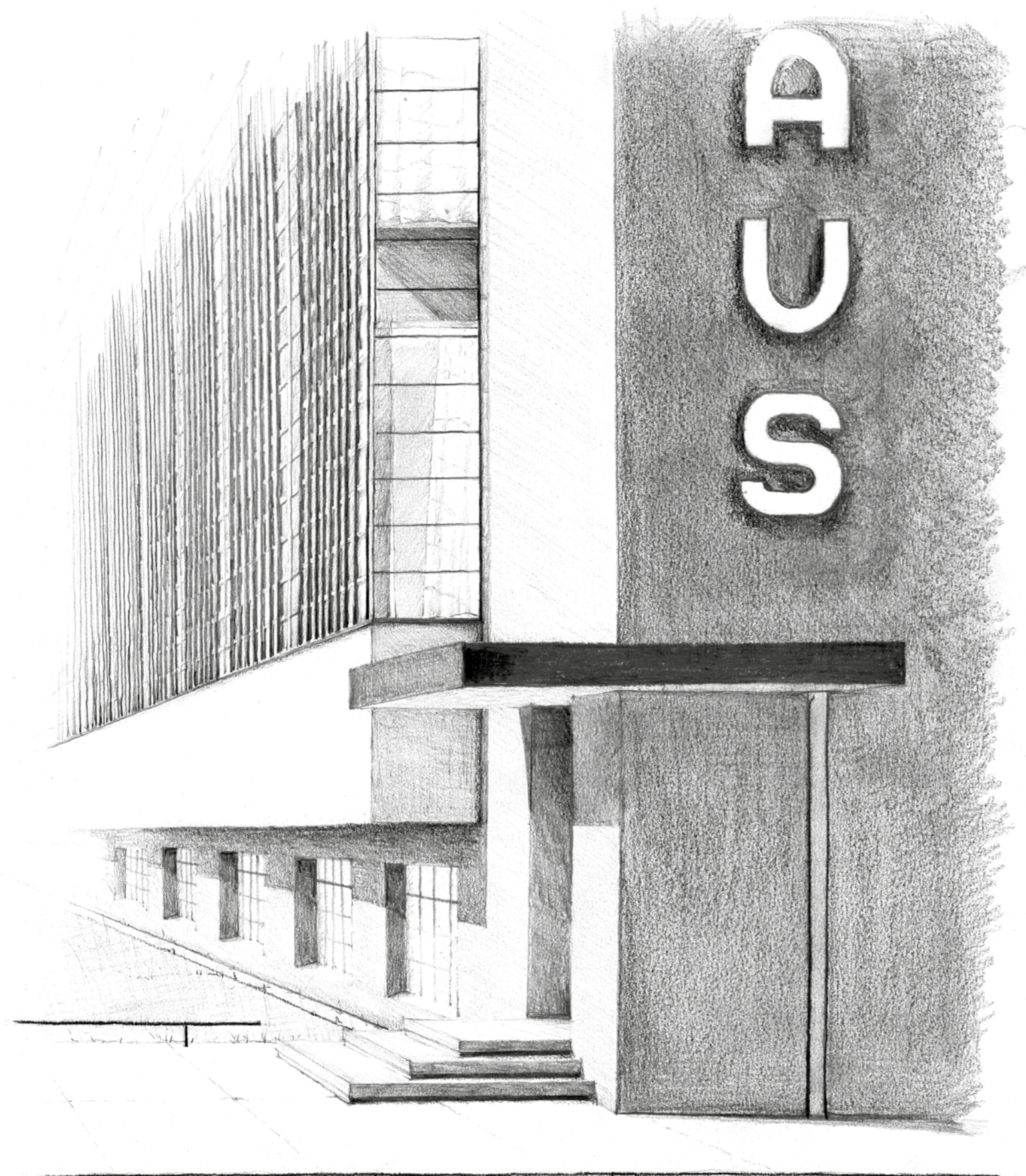

DRAWING MIES AND GROPIUS
ON THE TRAIL OF THE BAUHAUS

Danilo Teichert
Architektur Bachelor SS 2019
Supervisor: Prof. Dr. Natascha Meuser

To celebrate the 100th anniversary of the Bauhaus movement in 2019, the Dessau School of Architecture and the Illinois Institute of Technology, Chicago were launching a cooperation. Over the course of a one-week joint excursion to Berlin and Dessau, students from both institutions documented Bauhaus buildings through drawings and illustrations. The results were shown in an exhibition. Intensive education, not only intended to sharpen their senses of colour and form, but also to taught them the adequate use of materials.

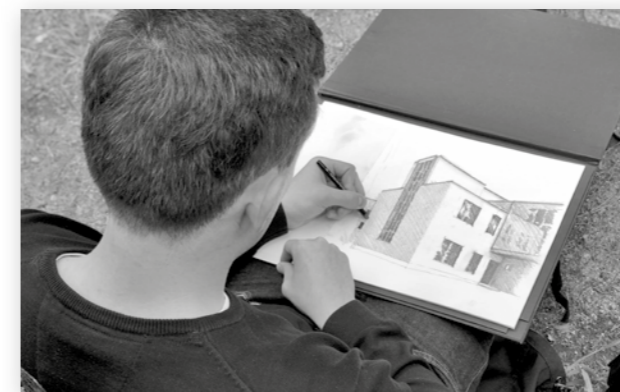
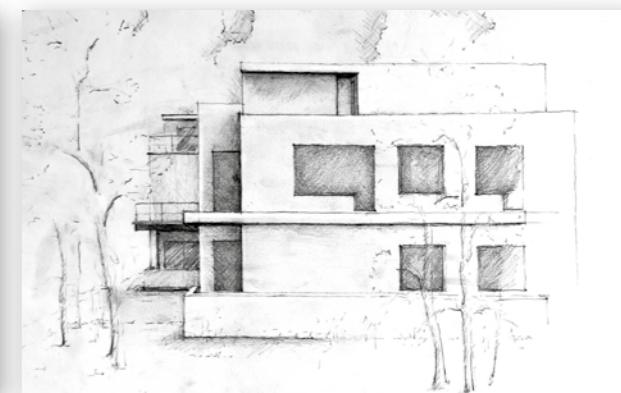
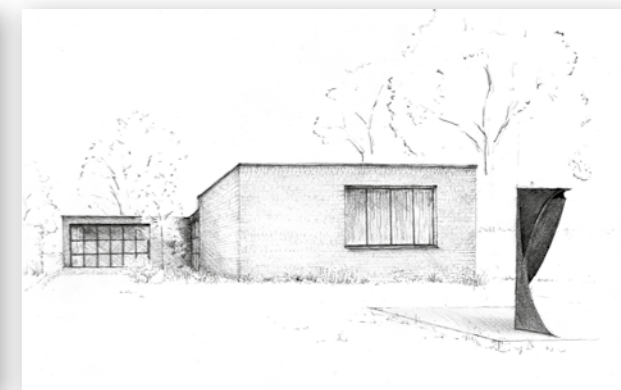

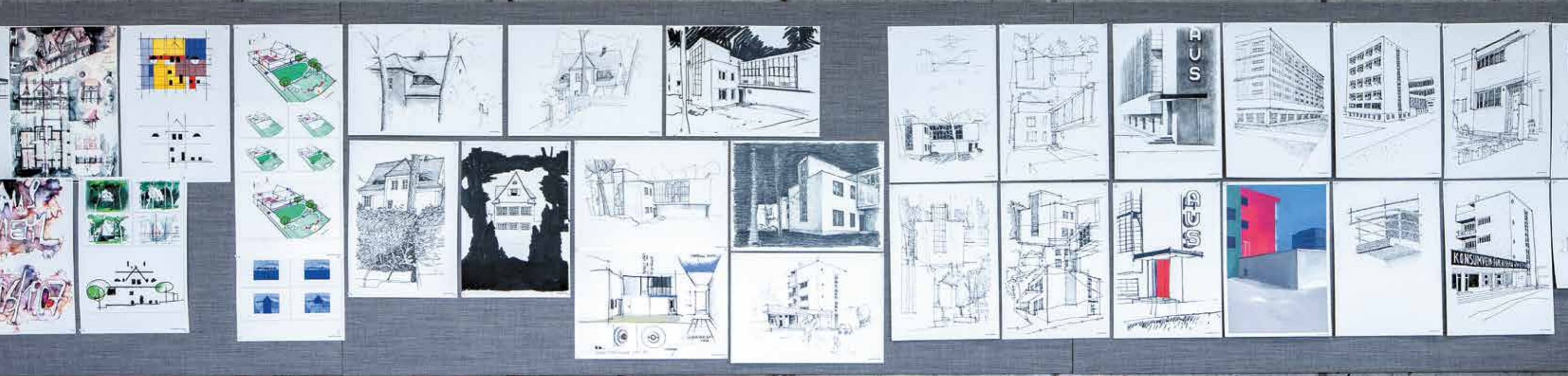

Ausstellung / Exhibition SS 2019
Drawing Mies and Gropius. On the Trail of the Bauhaus
Kooperation: Hochschule Anhalt/
Illinois Institute of Technology (I.I.T.), Chicago

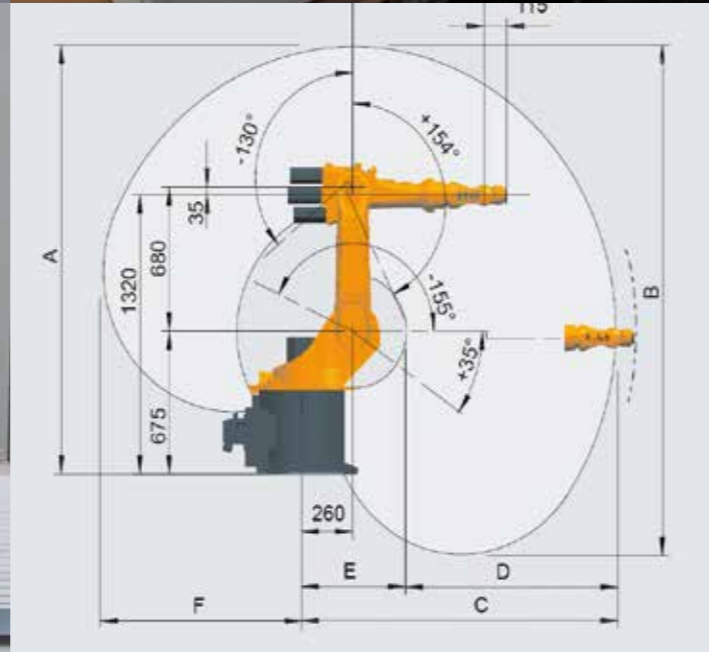
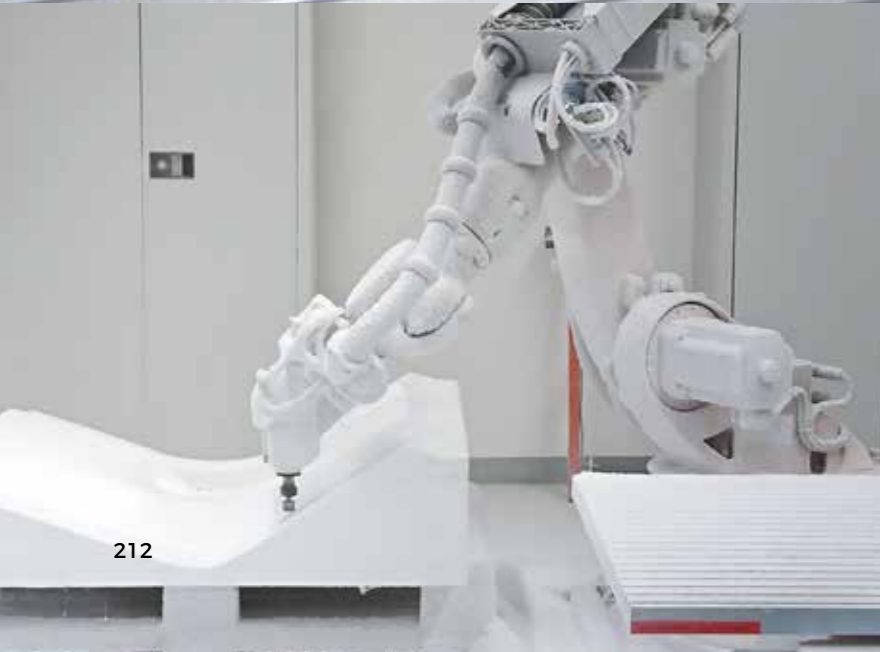

BETONMÖBEL CAMPUS BAUHAUS

**Stefan Bieber, Yvonne Hein,
Lena Jähn, Tina Witthohn**
Praxisprojekt 2018
Supervisors: Prof. Andreas Theurer,
Prof. Dr. Stefan Reich, Christian Pfützte mit
Unterstützung des RoboLab

Aufgabenstellung für das Praxisprojekt 2018 war es, ein Betonmöbel für den Campus Bauhaus zu entwerfen und 1:1 in textilbewehrtem Beton zu fertigen. Die Studierenden hatten die Möglichkeit, einfach und doppelt gekrümmte Flächen bzw. Freiformgeometrien umzusetzen. Die erforderlichen Schalungen wurden mithilfe des Roboters in unterschiedlichen Prozessen hergestellt.

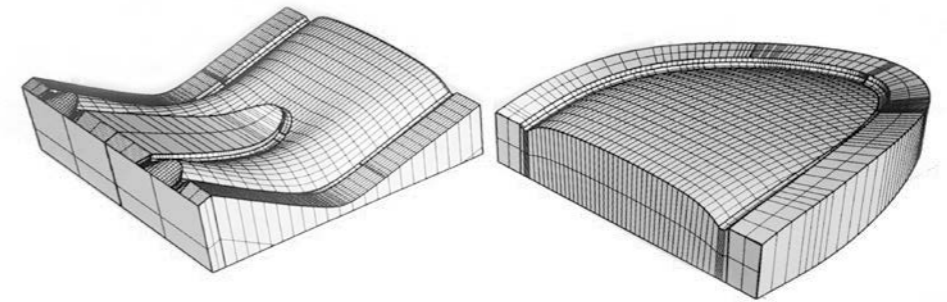

links: Arbeiten im RoboLab.
diese Seite: Entwurfsschritte bei der
Erstellung eines Betonmöbels.



**Menschen vor und
hinter den Kulissen**
People on Stage
and Behind the Scenes

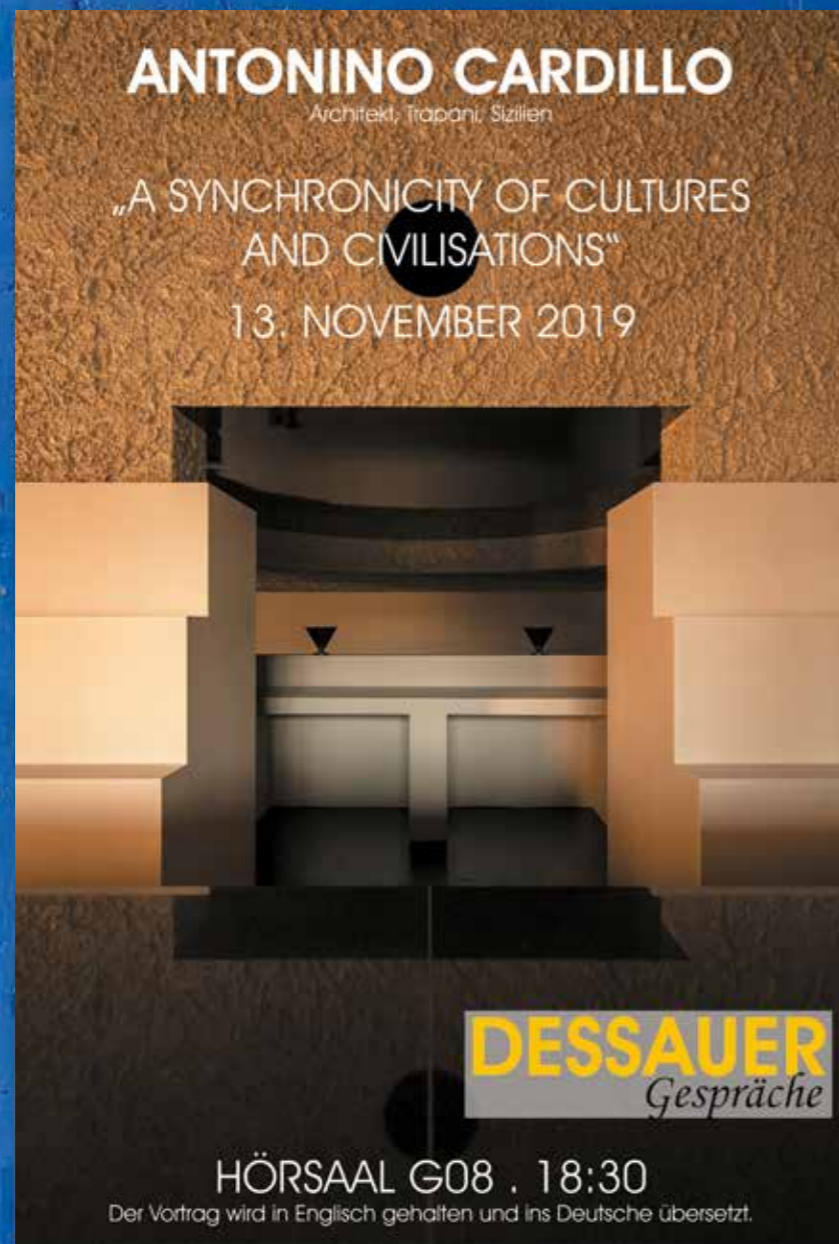

weitere Dessauer Gespräche im Wintersemester 2019/20:
 27.11.2019: Andreas Kipar, Landschaftsarchitekt Düsseldorf/Mailand
 2020: Jörg Trempler, Professor Kunstgeschichte und Bildwissenschaft, Universität Passau

Vortragsreihe Dessauer Gespräche

Johannes Kister

Die Dessauer Gespräche sind die zentrale Vortragsreihe des Fachbereichs. Über 100 Vorträge wurden seit 1996 gehalten: immer mittwochs, immer 18:30 Uhr. Hier wird mit Gästen Architektur und Aktuelles verhandelt, hier trifft »man« sich in der studentischen Öffentlichkeit – Lehrende sowie Bachelor- und Masterstudierende aller Semester. Die Vorträge sind in deutscher oder englischer Sprache und werden simultan übersetzt. Eine einzigartige Einrichtung, die sich bewährt hat im Sinne einer übergreifenden Präsenz für alle Studiengänge. Jedes Semester verfolgt eine thematische Ausrichtung, die sich oft aus einem gegenwärtigen gesellschaftlichen Diskurs entwickelt. Architektur ist aktuell.

The Dessau Talks are the faculty's central series of lectures. More than 100 speeches and interdisciplinary lectures have been held since 1996: always on a Wednesday at 6:30 pm. In the process, architecture and topical issues are discussed with guests; it is a meeting place in the students' public realm between colleagues bachelor and master's students of the term. The speeches are held in German and English and simultaneously interpreted. A unique institution that has been tried and tested in the sense of an overarching presence for all courses. Each term follows a thematic orientation often developing from a social discourse that is in the air. Architecture is relevant.

2018/19

18. April 2018
Anupama Kundoo, Indien
 Werkvortrag

25. April 2018
qbatur, Quedlinburg
 Dessauer Gespräche »regional«

16. Mai 2018
HG Merz, Berlin
 Second Life

23. Mai 2018
Bahama Soul Club, Braunschweig
 Komposition Produktion Präsentation

6. Juni 2018
Haas & Hahn, Niederlande
 Werkvortrag von Jeroen Koolhaas and Dre Urhahn

13. Juni 2018
Paul Schmelzer und Peter Weber, Dresden
 Alles oder Nichts

10. Oktober 2018
snarq architekten, Halle (Saale)
 Dessauer Gespräche »regional«

7. November 2018
Tobias Wulf, Stuttgart
 Stil oder Haltung

14. November 2018
Jan Störmer, Hamburg
 Komplexität und Haltung

28. November 2018
Lukas Imhof, Zürich
 Analoge Altneue Architektur

5. Dezember 2018
Daniel Altemeyer-Bartscher und Daniel Dratz
 Alumni-Doppel

16. Januar 2019
Denis Andernach, Frankenthal
 Vom Zeichnen von Häusern

3. April 2019
META architektur GmbH, Magdeburg
 Dessauer Gespräche regional

17. April 2019
Gertrude Ceppl-Kaufmann
 1900. Zeit der Utopien – Zur Topografie eines deutschen »Jahrhundertjahres«

8. Mai 2019
Lydia Ranke
 Bauhausworld

22. Mai 2019
Christoph Sattler, München
 Architektonische Entwicklung eines Mies-van-der-Rohe-Eleven

12. Juni 2019
Jonathan Sergison, London
 Werk und Lehre

19. Juni 2019
Roberto González, Barcelona
 Bauhausmuseum

13. November 2019
Antonino Cardillo, Trapani
 A Synchronicity of Cultures and Civilisations

27. November 2019
Andreas Kipar, Düsseldorf
 Paesaggio / Landschaft – Italien / Deutschland (K)ein Vergleich?

4. Dezember 2019
Zeitform Architekten, Halle (Saale)
Großmann Architektur, Halle (Saale)
 Dessauer Gespräche regional



Foto: Denis Esakov

Lehrwerkstatt Bauhaus 100 Architektur als Pädagoge

Sabine Thalmann

Im Rahmen des 100-jährigen Bauhaus-Jubiläums ging es bei der Neugestaltung der Lehrwerkstatt um die Frage, wie sich Lernen in der Zukunft verändern und welche Rolle die Innenraumplanung dabei als Pädagoge spielen wird. Aus diesem Anlass wurde ein Musterraum auf dem Dessauer Campus eingerichtet – mit prominentem Blick auf das Bauhaus-Gebäude von Walter Gropius. Bei der Planung standen die Digitalisierung von Wissensvermittlung sowie die Nutzung moderner Technik im Mittelpunkt, verbunden mit der Frage, wie sich unser Lernverhalten fördern und positiv beeinflussen lässt. Die Herausforderung bestand darin, räumliche und technische Konzepte umzusetzen, die derzeit noch nicht flächendeckend in Lehr- und Arbeitswelten verwirklicht sind, aber in wenigen Jahren zum Standard gehören werden. Somit soll die derzeitige Studierendengeneration in die Lage versetzt werden, die an der Hochschule Anhalt vermittelten Qualitäten in ihren eigenen Projekten zu realisieren. Der flexibel nutzbare Seminar- und Veranstaltungsraum trägt dazu bei, den Lehrbetrieb sowohl in digitaler als auch in analoger Form interessanter zu gestalten und damit eine größere Aufmerksamkeit in den Lehrveranstaltungen zu schaffen. In den kommenden Jahren soll der Raum von allen Lehrkräften in der Praxis genutzt und getestet werden, um im Anschluss evaluiert zu werden. Auf dieser Basis werden Fachbereich und Präsidium entscheiden, inwieweit die Raumkonzepte an den drei Standorten Bernburg, Dessau und Köthen stufenweise realisiert werden können. Das Projekt wurde mit den Produkten der Hersteller Brunner (Ausstattung) und Zumtobel (Licht) verwirklicht. Es handelt sich um eine Kombination aus Einbaumöbeln und modularen, multifunktional einsetzbaren Raumelementen, Konferenz- und Seminarbestuhlung sowie Arbeitsinseln und Ruhe-zonen. Die Gleichwertigkeit von analogen und digitalen Präsentationsmöglichkeiten war ein wesentlicher Parameter der Neugestaltung.

Bauhaus 100 Teaching Workshop Architecture as a Pedagogical Tool

The teaching workshop was redesigned as part of the centenary celebrations of the Bauhaus. The central question was how learning and teaching will change in the future and what role interior planning will play in pedagogy. A model space was built on the Dessau campus with a prominent view of Walter Gropius's Bauhaus building. The planning process particularly focused on the digitalisation of knowledge transfer and the use of modern technologies. These concerns were considered along with the question of how teaching methods can be supported and improved. The challenge was to implement spatial and technical concepts that have not been comprehensively realised in the fields of pedagogy and in work environments but will become standard practice in a few years. As such, the current generation of students will be capable of realising the qualities taught at the Anhalt University of Applied Sciences in their own projects. The flexible seminar and events room enables instructors to make their lessons, whether in a digital or analogue form, more engaging and thus encourage greater attention from their students. In the coming years, the room will be used by all instructors and tested in practice so that it can subsequently be evaluated. The faculty and a committee will then decide the extent to which the spatial concepts can be gradually introduced at the three locations in Bernburg, Dessau, and Köthen. The project was implemented with products by the manufacturers Brunner (fit-out) and Zumtobel (light). It comprises a combination of built-in furniture and modular, multifunctional room elements, conference and seminar seating, workstations, and quiet areas. The balance between analogue and digital presentation options was an important parameter of the new design.

Was ein gut gestalteter Begegnungsort leisten muss.

- Arbeiten
- Besprechen
- Erfinden
- Erholen
- Gestalten
- Lernen
- Netzwerken
- Präsentieren
- Ruhen
- Treffen
- Vernetzen
- ...

- Arbeitsplatz
- Ausstellungsraum
- Besprechungsraum
- Bibliothek
- Erlebnisraum
- Gruppenraum
- Konferenzraum
- Lernort
- Lounge
- Treffpunkt
- Vortragsraum

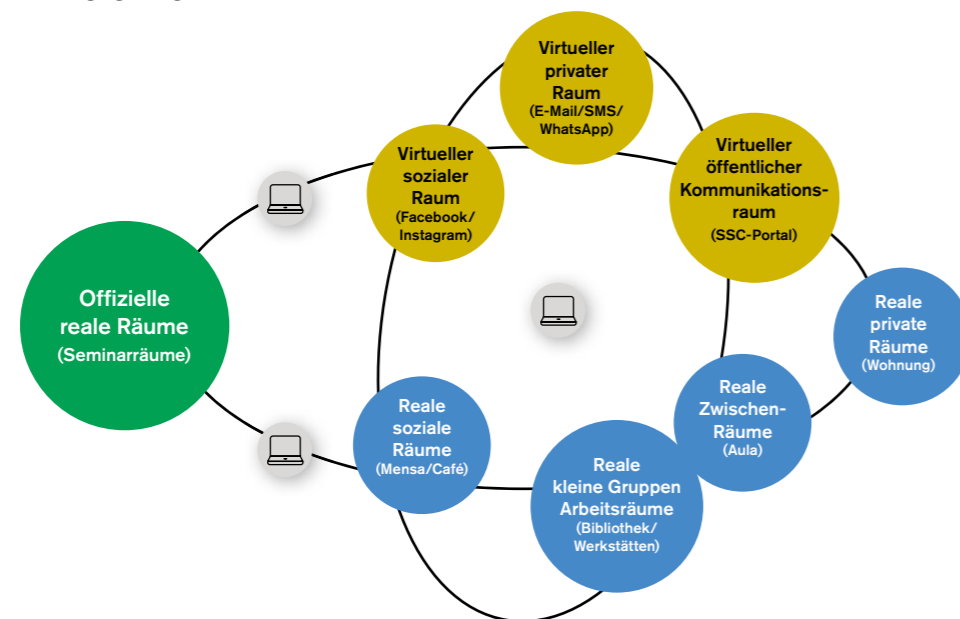



Fotos: Denis Esakov

Studienangebot Study Offer

Die Hochschule Anhalt bietet am Standort Dessau Studiengänge für Bachelor- und Masterstudierende im Fachbereich 3 und 4 an.

Fachbereich 3

Architektur Bachelor (Bachelor of Arts, 6 oder 8 Semester)
Architektur Master (Master of Arts, 4 Semester)
Architecture (DIA*) Master (Master of Architecture, 4 Semester), englisch

Denkmalpflege Master (Master of Science, 4 Semester)**
Architectural and Cultural Heritage Master (Master of Arts, 4 Semester), englisch

Design Research Master (Master of Science, 2 Semester)***
Dessau Summer School of Architecture (Zertifikatsstudiengang)

Managing Technology for Renal Care Centers (Zertifikatsstudiengang)
Architektur Bachelor an der Vietnamese-German-University (Bachelor of Arts, 6 Semester)

Membrane Structures Master (Master of Engineering, 4 Semester), BS, englisch
Membrane Structures (Hochschulzertifikat, 2 Semester), BS, englisch

Immobilien- und Baumanagement Bachelor (Bachelor of Science, 6 Semester)
Facility- und Immobilienmanagement Master (Master of Science, 4 Semester)

Vermessung und Geoinformatik Bachelor (Bachelor of Engineering, 7 Semester), Dual
Vermessung und Geoinformatik Bachelor (Bachelor of Engineering, 7 Semester)
Vermessung und Geoinformatik Master (Master of Engineering, 3 Semester)
Geoinformationssysteme Master (Master of Engineering, 4 Semester)

Fachbereich 4

Integriertes Design (Bachelor of Arts, 7 Semester)
Integrated Design (Bachelor of Arts, 3 Semester), englisch
Intermediales Design (Master of Arts, 7 Semester), online

* DIA = Dessau International Architecture Graduate School

** in Kooperation mit der Martin-Luther-Universität Halle-Wittenberg

*** in Kooperation mit der Humboldt-Universität zu Berlin und der Stiftung Bauhaus Dessau

BS = Berufsbegleitendes Studium (Fernstudium)

Dual = Dualer Studiengang

Weitere Informationen:

Hochschule Anhalt

Abteilung Studentische Angelegenheiten

Allgemeine Studienberatung

Bernburger Straße 55

D-06366 Köthen

Fon: +49. (0)3496 67-5203

Fax: +49. (0)3496 67-5299

studienberatung@hs-anhalt.de

<http://www.hs-anhalt.de>

Menschen vor und hinter den Kulissen
People on Stage and Behind the Scenes



Einrichtungen Facilities

01 LYZEUM

FB Design mit Dekanat, Hörsäle und Seminarräume, Plastische Werkstatt, SpaceLab, Digitale Werkstatt
Faculty of Design, Deanery of the Faculty of Design, lecture halls and seminar rooms, plastic arts workshop, SpaceLab, digital workshop

02 POLYSIUS-HAUS

FB Architektur, FB Facility Management, Computerpools, Virtual-Reality-Labor
Faculty of Architecture, Faculty of Facility Management, computer pools, Virtual Reality Laboratory

03 RICHTER-HAUS

FB Architektur, FB Facility Management, FB Design, Hörsäle und Seminarräume, Holz- und Kunststoffwerkstatt, Modellbauwerkstatt, Haustechniklabor, Werkstatt Fotografie, Videowerkstatt, Grafische Werkstatt, Hochschuldruckerei
Faculty of Architecture and Facility Management, Faculty of Design, lecture halls and seminar rooms, wood and plastics workshop, model-building workshop, laboratory of building services, photography workshop, video studio, graphics workshop, university printing shop

04 BILL-HAUS

Hörsäle, Seminarräume, Zentrale Wache, Poststelle
Lecture halls and seminar rooms, security control room, mail service

05 ROEBLING-HAUS

Institut für Membran- und Schalentechologien e.V., Baustoffprüflabor, Metallwerkstatt, Roboter-Labor
Institute for Membrane and Shell Technologies, building material test laboratory, metal workshop, robotics laboratory

06 STUDIERENDEN-SERVICECENTER / GÄSTEHAUS

Student Service Center / Guest House (ab September 2020)

07 GAUSS-HAUS

FB Geoinformation und Vermessung, Sekretariat, Seminarräume, Computerpools, Institut für Angewandte Geoinformatik und Raumanalysen e.V.
Faculty of Surveying and Geoinformatics, secretariat, seminar rooms, computer pools, Institute of Applied Geoinformatics and Spatial Analysis

08 AUDIMAX

FB Architektur, FB Facility Management, Dekanat FB AFG, Auditorium Maximum, Hörsäle und Seminarräume, Arbeitsräume/Studios
Faculty of Architecture, Faculty of Facility Management, Deanery of the Faculty of AFG, Auditorium Maximum, lecture halls and seminar rooms, workspaces/studios

10 BAUHAUS

FB Architektur, FB Design, Medienzentrum, Time Lab/Digital Publishing & Interaction Design, Computerpools
Faculty of Architecture, Faculty of Design, media centre, Time Lab/Digital Publishing and Interaction Design, computer pools

12 GÄSTEHAUS

Guesthouse

13 BASEDOW-HAUS

Studienkolleg, Hochschulsport
Preparatory college, university sports

15 DICKER-HAUS

FB Architektur, Bildhauerateliers, Modellbauwerkstatt, 3D-Plot, Fräs- und Laserlabor
Faculty of Architecture, sculptors' studios, 3D plot, laboratory for milling and laser operations

16 STATZ-HAUS

Denkmalpflege, Sprachenzentrum, Technische Verwaltung
Architectural and Cultural Heritage, Language centre, technical administration

17 BIBLIOTHEKEN

Hochschulbibliothek, Bibliothek der Stiftung Bauhaus Dessau
University library, library of the Bauhaus Dessau Foundation

M MENSA

Mensa, Studierenden-Servicecenter, Café am Campus
Mensa, Student Service Center, Café am Campus

E EXPO-WURM

Ausstellungs- und Multifunktionsraum
Exhibitions, lectures and workshops

W STUDENTENWOHNHEIM

Dormitory

Menschen vor und hinter den Kulissen
People on Stage and Behind the Scenes

Institute | Institutes

DEKAN

Prof. Dr. Matthias Höhne

PRODEKAN

Prof. Dr. Holger Baumann

Dessauer Institut für Architektur und Facility Management (DAF)

Prof. Johannes Kalvelage (Direktor)	Städtebau und Dorfplanung
Dr. Natasha Aruri (Prof. in Vertretung)	Stadtplanung
Prof. Dr. Gerd Förster	Baustofflehre und Baustofftechnologie
Matthias Hitschke (Prof. in Vertretung)	Haustechnik
Prof. Johannes Kister	Entwerfen und Baukonstruktion
Christoph Kohl (Prof. in Vertretung)	Städtebau
Prof. Dr. Michael Kuhn	Immobilienmanagement
Prof. Dr. Rudolf Lückmann	Baukonstruktion
Prof. Jens Nävy	Dienstleistungs- und Flächenmanagement
Matthias Schröter (Prof. in Vertretung)	Facility Management und Facility Services
Prof. Dr. Daniela Spiegel	Baugeschichte und Denkmalpflege
Prof. Dr. Matthias Tauber	Bauorganisation und Kostenrechnung
Prof. Mario Widmann	Baubetriebslehre

Dessauer Institut für Baugestaltung (DIB)

Prof. Carl Constantin Weber (Direktor)	Grundlagen der Gestaltung
N.N.	Architekturtheorie
Prof. Dr. Claus Dießenbacher	CAD und Entwerfen
Prof. Dr. Matthias Höhne	Baukonstruktion und Entwerfen
Prof. Dr. Natascha Meuser	Innenraumplanung
Prof. Beatriz Möller	Baukonstruktion und Entwerfen
Prof. Ralf Niebergall	Gebäudelehre
Prof. Stephan Pinkau	CAD und Baukonstruktion
Prof. Dr. Stefan Reich	Ingenieurhochbau

Prof. Axel Teichert	CAD und Baukonstruktion
Prof. Andreas Theurer	Künstlerische Grundlagen der Gestaltung
Prof. Stefan Worbes	Gebäudelehre und Entwerfen
N.N.	Bauklimatik

Institut für Geoinformation und Vermessung (IGV)

Prof. Dr. Lutz Bannehr (Direktor)	Geodatenerfassung und Sensorik
Prof. Dr. Holger Baumann	Geoinformationswesen
Prof. Dr. Norbert Gerhards	Liegenschaftsvermessung und Recht
Prof. Dr. Boris Kargoll	Geodätische Auwertetechnik
Prof. Dr. Ronald Jurisch	Mathematik und fachbezogene Informatik
Prof. Dr. Lothar Koppers	GIS und Digitale Bildverarbeitung
Prof. Dr. Heinz Runne	Ingenieurvermessung
Prof. Dr. Robert Off	Immobilienwirtschaft und Real Estate Development

AN-INSTITUTE

IMS Bauhaus Archineer Institutes e. V.

Prof. Dr. Robert Off / Gustavo Ramirez Lares	Direktoren
--	------------

agira Institut für Angewandte Geoinformatik und Raumanalysen e. V.

Prof. Dr. Holger Baumann / Prof. Dr. Lothar Koppers	Direktoren
---	------------

Building Matters UG Institut für Bauangelegenheiten

Prof. Axel Teichert Thomas Greiser (Geschäftsführer)	Direktor
---	----------

Lehrende | Faculty

Prof. Dr. Omar Akbar	Architekturtheorie
Dr. Jose Munoz Alvis	Elective
Peter Apel	Entwerfen
Siverin Arndt-Krüger	Entwerfen und Gebäudelehre
Dr. Regina Bittner	Design as Research, Thesis Talks
Torsten Blume	Master Thesis Colloquium
Cathrin Bothmann	Stone Restoration und Technics
Prof. Angelika Brzóška	Gestalten (Zeichnen)
Dr. Jan Büchsenfuß	Architekturtheorie und Stadtentwicklung
Roger Bundschuh	Entwerfen und Gestalten
Mary Copple	Workshop: Learning by Doing
Sebastian Felix Ernst	Entwerfen und Konstruktion
Mariane El Ghrayche	Design as Projection
Thomas Greiser	Kommunikation und Darstellung
Prof. Dr. Andrea Haase	Stadtentwicklung & Infrastruktur
Steffen Haferkorn	CAD Logic (3D-printing)
Sabine Hansmann	Academic Writing, Thesis Talks, Exposé
Michael Heinrichs	IT im FIM
Matthias Helmle	Entwerfen
Eric Helter	Entwerfen und Konstruktion
Udo Hertel	IT im FIM
Prof. Dr. Michael Hohl	Methoden/Methods
Ronny Hübner	Wood Restauration
Prof. Dr. Michael Kappert	Grundlagen FM
Sara King	Entwerfen, Städtebau
Tobias Kirschke	Geodateninfrastrukturen
Prof. Dr. Richard Koeck	The City Represented
Prof. Klaus Kozel	Methodologie der Denkmalpflege
Prof. em. Dr. Joachim Krausse	Design as Projection
Ivan Kucina	Entwerfen und Gestalten
Esteban Lamm	CAD Logic
Alexander Lech	CAD Logic (Grafik)
Johanna Meyer-Grohbrügge	Entwerfen und Gestalten
Marco Mondello	CAD Logic (BIM)
Sina Mostafavi	Entwerfen und Robotics
Prof. Thomas Nestler	Baurecht
Dr. Dulmini Perera	Entwerfen und Gestalten, Forschungsmethoden
Prof. Dieter Raffler	Gestalten
Dr. G. Dietmar Rode	Rethorik
Peter Ruge	Entwerfen und nachhaltiges Gestalten
Friederike Schäfer	Academic Writing, Thesis Talks, Exposé
Markus Schnierle	Technics
Dr. Angelika Seppi	Exposé, Elective, Colloquium
Fredrik Skatar	CAD Logic
Dr. Christian Stein	Elective
Dr. Peter Stolze	Internationales Marketing
Michael Sußmann	Methodologie der Denkmalpflege
Elke Szczesny	Projekt »Open Space – ein Gebäude für Grafik- und Medien-Start-ups«
Lars Teichmann	Landmanagement
Inés Toscano	Gestalten und Gender
Nilufar Tukhboeva	Islamische Architektur
Lilo Viehweg	Design as Research
Dr. Gernot Weckherlin	Theory Seminar, Thesis Talks, Design as Education

Mitarbeitende | Staff

Christine Andres	Denkmalpflege, Architectural and Cultural Heritage
Sairah Badar	CAD/BIM
Beeke Bartelt	Studiengangskoordination MA Architecture (DIA)
Michael Beckmann	Holzwerkstatt
Maria Blunk	Studiengangskoordination BA Architektur VGU Vietnam
Cornelia Böttner	Entwerfen
Matthias Brunner	Studiengangskoordination Bsc Immobilien- und Baumanagement
Carl Buchmann	Medientechnik/Roboterlabor
Michael Drewniok	Baustofftechnologie
Henning Dürr	Membrane Structures/Forschungsgruppe berg
Henry Foltin	Geodätisches Labor
Dr. Sandra Giegler	Studiengangskoordination MA Architecture (DIA)
Pia Grahl	Forschungsgruppe Straßenbau
André Günther	Systemadministration
Lukas Guffler	Ingenieurhochbau/Forschungsgruppe berg
Susanne Herz	Studiengangskoordination BA Architektur/Tragwerkslehre
Saskia Höhne	Denkmalpflege
Steffen Hofmann	Forschungsgruppe Straßenbau
Ulrike Jost	Studiengangskoordination MA Architecture (DIA)
Ali Khomami	Membrane Structures
Heike Kleine	Membrane Structures/Studiengang Managerin
Bernd Körsten	Projektmitarbeiter, internationale Studienbetreuung
Marina Krietzsch	Sekretariat Haushaltsführung
Julia Krüger	Ingenieurhochbau/Forschungsgruppe berg
Guido Lau	Holzwerkstatt
Uhle Lehmann	Systemadministration
Chen Yu Li	Projektmitarbeiter MA Architectural and Cultural Heritage
Yili Lu	Projektmitarbeiterin, internationale Studienbetreuung
Heinzpeter Lüdike	Forschungsgruppe Straßenbau
Christian Minning	Lehrkraft für besondere Aufgaben Vermessungswesen
Anja Müller	Dekanat/Internetmarketing/CAD
Sylvia Müller	Forschungsgruppe Straßenbau
Marlies Pasiëka	Forschungsgruppe Straßenbau
Christian Pfütze	Bauklimatik/Ingenieurhochbau
Carola Rauch	Studiengangskoordination MSc Facility- und Immobilienmanagement
Annemarie Reimann	Lehrkraft für besondere Aufgaben Architektur/Denkmalpflege
Bernd Renner	Mathematik/Auswertetechnik
Chelsea Schedler	Studiengangskoordination MSc COOP Design Research, Dessau Summer School of Architecture
André Schlecht-Pesé	Dekanat/Studiengangskoordination MA Architektur
Maik Schüler	Modellbauwerkstatt/Fräs- und Laserlabor
Nadine Schulz	Dekanatsassistentz
Josephine Singer	Immobilien- und Baumanagement
Shahriar Shahabi	Membrane Structures
Ole Spickermann	Fernerkundung Gyrocopter
Sarah Stipek	Membrane Structures
Dorothea Swiderek	Technische Gebäudeausrüstung
Christoph Ulrich	Fernerkundung/Gyrocopter
Sagar Vanapalli	Forschungsgruppe berg
Dirk Vetter	Flächenmanagement/Studiengangskoordination BSc Vermessung und Geoinformatik
Matthias Völzke	Studiengangskoordination MSc Geoinformationssysteme
Simone Wagner	Sekretariat Dekanat
Peter Weise	Medientechnik und Geodätisches Labor
Harald Werner	Systemadministration
Kathrin Wohland	CAD/GIS
Christian Wolf	GIS und raumbezogene Anwendungen
Sascha Ziese-meier	Forschung Geoinformationssysteme

Autoren und Akteure

Authors and Contributors

- Abdwin, Saeed 113
 Ahlmann, Tino 198, 200, 202, 205
 Ahmed, Mohamed (Farid Aly) Sayed 101
 Ahsan, Md. Mushfique 115, 121
 Alsaied, Ahmad 170, 177
 Amon, Esteban 113
 Apel, Peter 75, 79, 81, 83, 226
 Aruri, Natasha 130, 135, 139, 224
 Asharedah, Ohoud 164
- Badr, Hossam 121
 Bärtsch, Anita 170, 177
 Baumgardt, Bruno 195
 Baumgartl, Stephan 164f.
 Bellmann, Sarah 206
 Bernegger, Seraina 194, 206
 Bieber, Stefan 213
 Bitarafan, Kyanoush 119
 Bittner, Regina 50, 226
 Blunk, Maria 175, 227
 Boetker, Jan 113
 Bondarenko, Valentyna 95
 Böttner, Cornelia 26, 185, 187, 189, 191f., 227
 Brehm, Mark Philipp Darius 196
 Brück, Andreas 130f., 135, 139
 Buchholz, Antje 67, 91, 93, 95
 Buchmann, Carl 113, 227
 Büchschuß, Jan 164f., 226
 Bundschuh, Roger 23, 67, 69, 91, 93, 226
- Campbell, Randell 63
 Cepl, Jasper 11, 71
 Chan, Nora 75
 Cheah, Teck Wei 81
 Chebina, Oksana 63, 137
 Chiang, Yu-Chou 77
 Chiao, Lu 198
 Chiste, Flavia 173
 Chong, Wan Yee 63
 Chun, Yan Mai 103
 Conrads, Martin 130–132
 Cook, Peter 37–39
- Dahham, Noora 63
- Elbanna, Maged 115, 121
 Elmannae, Muhannad 115
 Elnaggar, Mahmoud A. 169
- Engbers, Kai-Joseph 198, 200, 202
 Errichsen, Elena 193
 Ewert, Carmen 174
- Feist, Nathalie 63, 157
 Feldmann, Nico 198
 Flores, Eva Abuerto 79
 Fournier, Colin 38
 Fröbel, Friedrich 45
- Garcia, Samuel Alejandro Carrillo 167
 Gerkan, Meinhard von 165
 Giedion, Sigfried 36
 Giegler, Sandra 13, 15, 21, 227
 Ginting, Jeanesty 200, 205
 Glockner, Otto 113
 Gomez, Delta 63
 Gropius, Walter 21, 44–48, 209f., 219
 Gruda, Sejla 193
 Günther, Maria-Luisa 161
- Hage, Jason 117, 119
 Haiman, Ivan 23
 Hamead, Amro 117, 119, 127
 Haselwander, Manuel Sebastian 198, 200, 205
 Haues, Shara 177
 Hehl, Rainer 23
 Hein, Yvonne 213
 Helten, Leonhard 174f.
 Helter, Eric 23, 85, 129, 142, 226
 Henniges, Dennis 206
 Herbig, Mike 113
 Herndon, Nate 113
 Herrera, Antonio 119
 Herz, Susanne 159, 227
 Hoesli, Bernhard 33–35, 171
 Hoffmann-Kuhnt, Thomas 63
 Höhne, Matthias 7, 9, 12f., 60, 147, 151, 153, 155, 157, 161, 176f., 224
 Hooi, Liew Chung 85
 Huang, Mengyuan 197
 Humboldt, Wilhelm von 43f.
- Isufi, Gjiltine 63, 83
- Jabr, Yaseen 115, 121
 Jacoby, Alfred 13, 23, 33, 36
 Jacoby, Kaia 36
 Jähn, Lena 213
- Jain, Shubham 193
 Jakobasch, Christopher 155, 161
 Jinxin, Liu 195
 Johannemann, Lydia 198, 200, 205
 John, Natascha 198, 205
 Jun, Chin Yan 87
- Kalvelage, Johannes 22f., 97, 99, 224
 Kandinsky, Wassily 45, 47
 Kastrati, Valmir 121, 125
 Kehrlé, Sarah 198
 Khaez, Adib 115, 117, 119
 Khalidi, Hamed 23
 Kister, Johannes 13, 15, 23, 26f., 185, 187, 189, 191f., 217, 224
 Kiu, Lam Sa 113
 Kium, Yong Fui 63
 Kohl, Christoph 89, 224
 Kong, Melissa Wyeng-Tse 144
 Kozel, Klaus 174f., 226
 Kozhevatoa, Polina 173
 Kraetsch, Angelina 206
 Krausse, Joachim 52, 226
 Kretzer, Manuel 113, 117, 123, 125
 Krüger, Julia 170, 227
 Kübler-Buchegger, Janine Leonie 63
 Kucina, Ivan 23, 65, 71, 73, 89, 144, 226
 Kurani, Mohamed Abdo 115
 Kutlahmetova, Gulfia 119
- Lakrisenko, Anastasia 63
 Landwehr, Janet 63, 147, 164
 Lanina, Ksenia 115
 Latour, Bruno 33f., 39
 Le Corbusier 33f.
 Leer, Quenna 117
 Le-Mentzel, Van Bo 230
 Lerup, Lars 63
 Lescop, Laurent 23
 Li, Qianqian 198
 Lim, Tian Jing 63, 71
 Lixian, Liu 198
 Lohaus, Dominique 113, 117
 Lu, Yang 23
 Lückmann, Rudolf 174
- Maharjan, Rumi Singh 63
 Mangasaryan, Arpi 23
 Mansour, Mohammed 113, 119, 123
- Martinez, Lizzette López 63, 99
 Marx, Manuel 198, 202, 205
 Massarova, Ruslana 131, 138f.
 Mastalski, Aleksander 113
 Mathys, Christoph 192
 Mazlan, Mohamad Shazwan 77, 115, 121
 Mei, Queena Ler 121
 Meuser, Natascha 13, 16, 30, 41, 103, 105, 107, 109, 111, 181, 207, 209, 224, 231
 Meyer-Grohbrügge, Johanna 23, 137, 144, 226
 Mihai, Ralf-Marcus 198
 Ming, Gary Chong Wee 65
 Ming, Oscar Yan 131, 135
 Moharram, Mohammed Saad 117
 Möller, Beatriz 153, 155, 224
 Mostafavi, Sina 23, 77, 113, 115, 117, 119, 121, 123, 125, 127, 129, 226
 Muhammad Ali, Imran Suhaimi bin 187
 Müller, Anja 192, 227
 Müller, Beatriz 159
- Naumann, Martin 117
 Nguyen, Nu Hong Yen 151, 206
 Nguyen, Quangduc 207
 Niebergall, Ralf 13, 15, 17, 23, 101, 147, 149, 224
- Oduor, Neady 113, 117
 Off, Robert 167, 225
 Oh, Jinyi 63
 Oppelt, Luise Eva Maria 117
 Ordevska, Andrea 169
 Ortiz, Sabrina 121
 Osmolovska, Marina 113
 Otto, Frei 37, 39
 Oxman, Robert 63
 Ozdemir, Altyn 16
- Pascal, Joanne 23
 Passek, Markus 63
 Patzak-Poor, Jürgen 91, 93, 95
 Peinado, Ulises 23
 Perera, Dulmini 23, 65, 226
 Petzold, Lisa 169, 177
 Pfütze, Christian 177, 213, 227
 Pham, Thien Huong 198
 Pietsch, Marie Isabell 113
- Pinheiro, Vasco 23
 Pinkau, Stephan 13, 50, 173, 224
 Pomilio, Barbara 63
 Porter, Catherine 34
 Preschel, Ilka 23
 Prima, Billy Novia 97
- Qiao, Lu 202
 Quittenbaum, Maria 169
- Rahimi, Niloufar 113
 Ramachandran, Anjali 23
 Rasbasch, Katja 113
 Reich, Stefan 213, 224
 Riant, Paul 93
 Rivas, Silvia Amor 185
 Roth-Cerina, Mia 185, 187, 189, 191
 Rousseau, Jean-Jacques 45
 Rowe, Colin 34
 Ruge, Peter 73, 87, 127, 226
 Rümmler, Tobias 63, 159
- Safronov, Dmytro 177
 Saleh, Ahmed 115
 Sanchez, Johan Andres Rey 69
 Sanne, Nico 165
 Schäffner, Wolfgang 50
 Schafhausen, Nicolaus 23
 Schlemmer, Oskar 47
 Schmid, Janick T. 163
 Schmid, Oskar 63
 Schmidt, Juliane 198, 200, 202
 Schnaithmann, Christine 52
 Schneider-Wessling, Erich 176f.
 Schubert, Karsten 171
 Ser, Fu Yi 113
 Shah, Janishka 23
 Shang, Yuqin 198
 Shelkovska, Mariia 63, 67
 Shing, Soh You 63, 89, 142
 Shvets, Polina 22f.
 Šik, Miroslav 192
 Sinani, Megi 173
 Singh, Karsimran 121
 Singh, Rajani 63
 Skyba, Rostyslav 91
 Soliman, Karim 169
 Song, Ruiqing 207
 Spiegel, Daniela 23, 224
 Spier, Marie 198
- Stiehl, Sophie 177
 Stoib, Anian Till 113
 Struck, Jan 198
 Surova, Yuliia 73
- Tang, Rujia 195, 206
 Teichert, Danilo 209
 Teichert, Julian Faro 181
 Terragni, Attilio 23
 Tey, Lovie 22f., 131
 Thaler, Luise Katharina 198, 202
 Thalmann, Sabine 219
 Theurer, Andreas 151, 157, 161, 163, 181, 198, 200, 202, 205, 213, 225
 Tien, Nicole Hooi Yi 105
 Toscano, Inés 16, 226
 Tyrangiel, Harry 36
- Ullrich, Philipp 177
 Utzon, Jørn 36f.
- Varela, Arturo 23
 Varshith, Josephin Latha Ashish 113, 193
 Veilleux, Jean Guillaume 198, 200, 202
 Venugopal, Vidhya Trinity 22f., 119
 Vitruv 18
 Vujovic, Marija 170, 177
- Wan, Arise 117, 140
 Weber, Carl Constantin 196f., 224
 Weber, Peter 161, 163
 Wee, Joyce Yi Qin 107
 Wittgenstein, Ludwig 35
 Witthohn, Tina 189, 213
 Wong, Zhen Fai 109
 Woodrow, Laura 113
 Wu, Tingting 170, 207
- You, Zhou 149
 Yuanyuan, Chen 191, 195
- Zaki, Kamal Amgad Mohamed 117, 119, 129
 Zeidler, Rafaela 52
 Zhang, Fanguan 111
 Zhao, Lingyue 170, 207
 Zhen, Mei 140
 Zhu, Ziqiang 200
 Ziener, Julia 117

NEXT GENERATION

Camping im Tiny Bauhaus Junge Architekten und Aktivisten eröffnen das Bauhausjahr mit politischer Kunst

Künstlerische Leitung: SAVVY Contemporary
in Kooperation mit Van Bo Le-Mentzel

Im Rahmen des 100-jährigen Bauhaus-Jubiläums kuratierte die *Tinyhouse University* unter der künstlerischen Leitung von Van Bo Le-Mentzel die Wanderausstellung *Wohnmaschine*. Es handelt sich dabei um ein 15 Quadratmeter großes Tiny House, ein Nachbau des ikonischen Bauhausgebäudes im Maßstab 1:6. Damit wollen die Künstler einen Beitrag zum Thema »Bezahlbarer Wohnraum in Modulbauweise« leisten. Die *Wohnmaschine* wurde vom 7. bis zum 23. Januar 2019 von der Berliner Künstlergruppe SAVVY Contemporary mit einem politisch-künstlerischen Programm bespielt. Auf kleinstem Raum fanden im Beisein internationaler Performance-Künstler und -Künstlerinnen unter anderem Workshops, Ausstellungen, Konzerte, Diskussionen und Filmvorführungen statt. Diese wurden an unterschiedlichen Standorten in Dessau öffentlich gezeigt.

Tinyhouse University curated the travelling exhibition "Wohnmaschine", under the artistic direction of Van Bo Le-Mentzel, as part of the centenary celebration of the Bauhaus. The centerpiece of the exhibition was a 15-square-metre replica of the iconic Bauhaus building on a scale of 1:6. The artists created it with the aim of making a contribution to the field of affordable modular housing. The Berlin-based artist group SAVVY Contemporary used the "Wohnmaschine" as a venue for an artistic and political programme between 7 and 23 January 2019. Workshops, exhibitions, concerts, discussions, and film showings took place in the presence of international performance artists within the tiny space. These were shown publicly in various locations in Dessau.

SPINNING
TRIANGLES: DESSAU

THE NOW
IS A
CONVULSION.
A PANICKED,
HYPER-MEDIATIZED,
HYPER-SHARED,
HYPER-OBSCURING,
HYPER-REAL,
HYPER-PUBLIC
FRENZY.

IGNITION OF A SCHOOL OF DESIGN
04.01.–22.01.2019
A T Hochschule Anhalt, VorOrt Haus Dessau

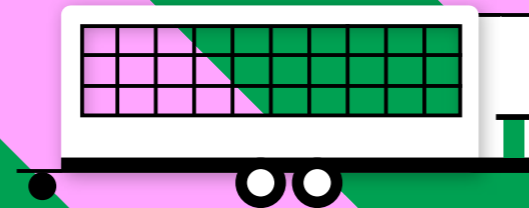

Aktionskunst an der Fensterfront
Foto: Natascha Meuser

SAVVY CONTEMPORARY
THE LABORATORY OF FORM-IDEAS
PROJEKTE
2019



Inhalte: <https://savvy-contemporary.com/en/projects/2019>

SPINNING TRIANGLES:
ANSTOSS ZU EINER
SCHULE FÜR
GESTALTUNG

Aktionen des Berliner Künstlergruppenkollektivs SAVVY Contemporary mit dem Titel SPINNING TRIANGLES. In Kooperation mit dem VorOrt Haus Dessau und der Hochschule Anhalt, im Rahmen des 100-jährigen Jubiläums des Bauhausjahres 2019. Die Ausstellung wird vom 4. bis zum 22. Januar 2019 im VorOrt Haus Dessau gezeigt. Die Ausstellung wird von der Berliner Künstlergruppe SAVVY Contemporary kuratiert. Die Ausstellung wird von der Berliner Künstlergruppe SAVVY Contemporary kuratiert. Die Ausstellung wird von der Berliner Künstlergruppe SAVVY Contemporary kuratiert.

BERLIN 04.01.–22.01.2019
Internationaler Workshop
BERLIN 24.01.–27.01.2019
Internationaler Workshop
KUNSTHAUS 04.01.–26.01.2019
Symposium und Workshop
BERLIN 27.01.–30.01.2019
Schule für Gestaltung
HONGKONG 26.01.–12.10.2019
Schule für Gestaltung



Die Wohnmaschine wurde als temporärer Veranstaltungsort von der Aktionskünstlergruppe SAVVY genutzt. Die Auftaktveranstaltung fand im Januar 2019 auf dem Dessauer Campus statt.
Foto: Natascha Meuser; Foto 1: Thomas Greiser

Projekte 49

Linke Seite: <https://savvy-contemporary.com/en/events/2019>
Fotos: Natascha Meuser
Foto unten links: Thomas Greiser

IMPRESSUM

Die *Deutsche Nationalbibliothek* verzeichnet diese Publikation in der *Deutschen Nationalbibliografie*; detaillierte bibliografische Daten sind im Internet abrufbar über: <http://dnb.d-nb.de>.

ISBN 978-3-96057-080-6 (Print)
ISBN 978-3-96057-081-3 (Online)

© 2020 Hochschule Anhalt, Dessau
Fachbereich Architektur, Facility
Management und Geoinformation
Postanschrift: Postfach 2215,
06818 Dessau-Roßlau
Hausanschrift: Bauhausstraße 5,
06846 Dessau-Roßlau
www.hs-anhalt.de

Urhebernennungen stammen von den beteiligten Autoren selbst. Für die Richtigkeit dieser Angaben übernimmt die Hochschule Anhalt keine Gewähr.

Dieses Werk ist urheberrechtlich geschützt. Jede Verwendung außerhalb der Grenzen des Urheberrechtsgesetzes ist ohne Zustimmung der Hochschule Anhalt unzulässig und strafbar. Dies gilt insbesondere für Vervielfältigungen, Übersetzungen, Mikroverfilmungen sowie die Einspeicherung und Verarbeitung in elektronischen Systemen. Die Nennung der Quellen und Urheber erfolgt nach bestem Wissen und Gewissen.

Herausgeber

Matthias Höhne im Auftrag der Hochschule Anhalt

Koordination und Redaktion

Konstantin Krüger
Natascha Meuser
Nadine Schulz

Übersetzung

Comlogo

Lektorat

Uta Keil (deutsch)
Alfred Visser (englisch)

Grafische Gestaltung

Severin Wucher

Druck

UAB BALTO print, Vilnius
www.baltoprint.lt



Hochschule Anhalt

Anhalt University of Applied Sciences