

Computer-aided Control of Sensorimotor Skills Development in Operators of Manufacturing Installations

Rustam Fayzrakhmanov, Ivan Polevshchikov and Anatoly Polyakov

Perm National Research Polytechnic University,

Department for Information Technologies and Computer-Based Systems, Perm, Russia

fayzrakhmanov@gmail.com, i.s.polevshchikov@mail.ru, squarepants_07@mail.ru

Keywords: Training Simulation Complexes, Computer-Aided Training Systems, Sensorimotor Skills.

Abstract: In this paper we introduce a novel model and method to increase the effectiveness of training operators of manufacturing installations. The proposed mathematical model describes main aspects of the process of training and development of sensorimotor skills. In contrast to existing models, our mathematical model incorporates dynamic characteristics of the skill development process and exponential learning curves which are used in assessing the performance of motor actions and development of control actions. We implemented the model and method as a component of our AnyCrane training simulator for crane operators. AnyCrane training simulator is a framework for realistic simulation of environment in ports, cranes, personal, physics and different technological processes. Our case study demonstrated effectiveness of the approach presented in this paper. The time necessary for moving a cargo decreased by 19%, the precision of load-unload operations increased by 30%, and the smoothness of crane turning has been increased by 36%.

1 INTRODUCTION

An effective use of modern manufacturing installations is determined by the quality of training which operators had in the past. Low quality of technological processes and high level of accidents and injuries are often a consequence of insufficient development of necessary sensorimotor skills in operators.

An operator must have required skills to timely and accurately perform necessary technological operations according to the desired process trajectory, to have necessary knowledge, be able to evaluate the real course of the technological process and choose the most effective actions.

Therefore, the problem of increasing the effectiveness of training operators of technological processes in order to develop necessary level of professional sensorimotor skills within a relatively short period of time is of paramount concern. To achieve this goal different computer-aided training systems (CTSs) and computer simulators were developed.

However, despite the presence of a large number of research studies in the field of professional training

automation, the problem of developing professional skills in operators of technological processes with the use of training simulators is not developed enough.

2 STATE OF THE ART

A lot of research is dedicated to the problem of automated management and control of the professional skills development and, in particular, professional sensorimotor skills of operators of technological systems. State-of-the-art research addresses the following aspects:

- problems of professional skills formation, in particular, mathematical modeling of skills developing processes [1] – [2];
- development and usage of training complexes for professional training of operators of various technological processes [3] – [4];
- models and methods for constructing CTSs and their individual components [5] – [6].

It is worth mentioning that there are still many open questions which are to be answered. For example, the most relevant to us is how to control the development of specific professional skills and

adequately assess their level of maturity using computer simulators and serious games. Thus, it requires to have a full control on the training process selecting a specific set of assignments and setting a necessary level of their complexity.

An effective training with the use of simulators should take into account the following aspects:

- an algorithm for forming a set of relevant sensorimotor skills and based on the iterative nature of obtaining each skill;
- taking into account complex relations between various technological quality characteristics, used to access the success of training;
- defining the actual level of skill in case of incomplete initial data of established standards on performing technological operation;
- a large amount of motor functions combined with operating of several mechanisms at once.

3 MATHEMATICAL MODEL OF THE SKILLS DEVELOPMENT CONTROL SYSTEM

To solve this problem, a mathematical model of the automated control system for the development of operator's professional sensorimotor skills through the exercises using training simulation complexes (TSCs) is proposed. This model was integrated and tested on the AnyCrane framework [7].

We aim at the following problem: for the minimal training time (the execution of exercises designed for

TSC), the performance of the technological operation must be brought to automatism at a given quality

level. That is, $T_{tr.} = \sum_{g=1}^{N_{ex.}} T_g \rightarrow \min$, wherein for

$$\forall g = \overline{1, N_{ex.}} :$$

$$T_g = f_{imp.}(U_g^{dec.}, U_g^{rek.}) = \sum_{v=1}^{N_g^{imp.}} T_{gv} - \text{the time } T_g$$

for multiple execution of the g -th exercise depends on the set of decisions $U_g^{dec.}$ at the end of each v -th execution and the set of advisory influences (recommendations) $U_g^{rek.}$ to the learner in the process of each v -th execution (T_{gv} – the time when the g -th exercise was performed);

$K_{gh} \geq K_{gh}^{thr.}$ – the quality of technological operation execution, determined by the parameters K_{gh} (where $h = \overline{1, N_{par.}}$), must comply with the standards, i.e. threshold values $K_{gh}^{thr.}$;

$N_g \geq N_g^{scl.}$ – the exercise is performed a specified $N_g^{scl.}$ number of times in a row at the required level of quality (the action is fixed to automatism).

The set of dependencies between mathematical model parameters is shown schematically in Figure 1.

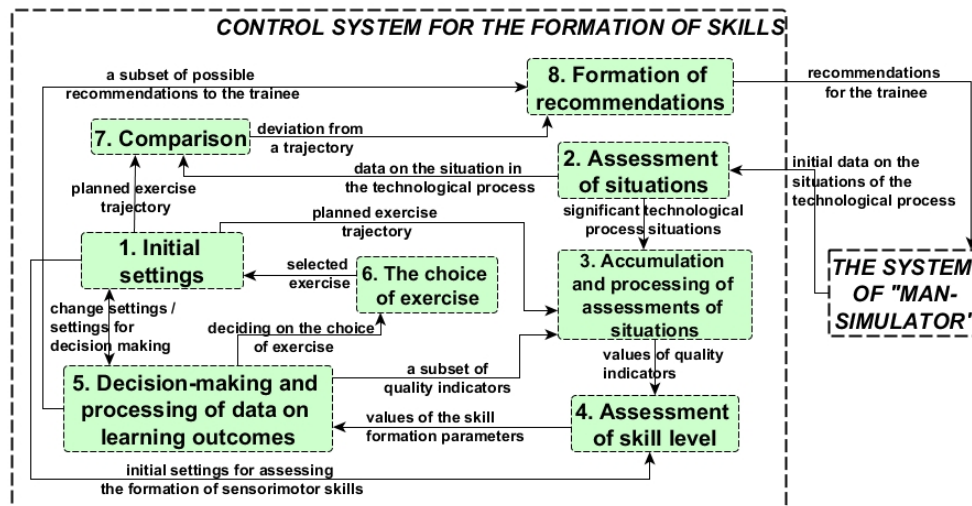

Figure 1: Scheme of control system for the formation of sensorimotor skills.

Block 3 (Figure 1) collects primary data on the process of sensorimotor skill formation (obtained in block 2), and on basis of processed data, the values of the quality indicators measured during the exercise are calculated, which constitute the set $X_{qual.}^{used} \subseteq X_{qual.}$, where $X_{qual.}$ is the set of all the quality indicators associated with the exercise ($|X_{qual.}| = N_{qual.}$). Quality indicators characterize the results and correctness of motor actions. Examples of indicators: the time of the operation; result accuracy; number of emergency situations; accuracy of the actions sequence compared with the optimal trajectory $T_{pl.}$.

In block 3, the following are formed:
 $P_{trm.} = \{P_r^{trm.} | r = 1, N'_{trm.}\}$ – set of terminal indicators values (calculated once after the completion of the exercise or part of it);
 $P_{dyn.} = \{P_s^{dyn.}(t_j) | s = 1, N'_{dyn.}, j = 1, N_s^{dyn.}\}$ – a set of dynamic indicators values (measured multiple times during the exercise) at time moment t_j ($N_s^{dyn.}$ – the number of measurements by the s -th indicator), wherein $|X_{qual.}^{used}| = N'_{qual.} = N'_{trm.} + N'_{dyn.}$.

Block 4 evaluates each step in the sensorimotor skill formation, the success of which is determined by whether the operator performed the exercise a specified number of times with the required quality or not. Thus, it calculates the degree of automatism in a trainee. Each new stage differs from the previous one by the addition of new estimated primary quality indicators.

The model's parameters (the coefficients of mastery) that determine the quality of the technological operation execution as the degree of compliance with the standards, represent the dimensionless values on the interval [0;1] obtained by processing the data on the quality indicators calculated in block 3:

$M_{trm.} = \{K_r^{trm.} | r = 1, N'_{trm.}\}$ and
 $M_{dyn.} = \{K_s^{dyn.}(t_j) | s = 1, N'_{dyn.}, j = 1, N_s^{dyn.}\}$ – sets of mastery coefficients by terminal and dynamic indicators, respectively;
 $M_{agr.} = \{K_s^{agr.} | s = 1, N'_{dyn.}\}$ – set of aggregated

mastery coefficients by dynamic indicators, where

$$K_s^{agr.} = N_s^{dyn.} \sqrt{\prod_{j=1}^{N_s^{dyn.}} K_s^{dyn.}(t_j)}.$$

Values from $M_{trm.}$ and $M_{dyn.}$ are calculated, mainly, on the basis of Mamdani algorithm fuzzy inference procedure, where a system of production rules is constructed to compare each primary index of the mastery coefficient. Norms are defined by fuzzy sets determined as linguistic variables of the rules system. The usage of fuzzy inference required due to the incompleteness of the initial information on standards, identified with the involvement of experts [8].

The quality of technological operation performance as a whole is characterized by an integrated indicator – the complex mastery coefficient:

$$K_{mast.} = \frac{\sum_{r=1}^{N'_{trm.}} W_r^{trm.} K_r^{trm.} + \sum_{s=1}^{N'_{dyn.}} W_s^{dyn.} K_s^{agr.}}{\sum_{r=1}^{N'_{trm.}} W_r^{trm.} + \sum_{s=1}^{N'_{dyn.}} W_s^{dyn.}}, \text{ where}$$

$W_r^{trm.} \in M_{weig.}$ and $W_s^{dyn.} \in M_{weig.}$, and $M_{weig.}$ – the set of weights of the quality indicators calculated in block 1.

Compliance with quality is reflected by the indicator $I_{mast.}$ of successful ($I_{mast.} = 1$) or unsuccessful ($I_{mast.} = 0$) exercise performance:

$$I_{mast.} = 1, \text{ if } (\forall r = 1, N'_{trm.}, \Delta_r^{trm.} \geq 0) \wedge (\forall s = 1, N'_{dyn.}, \Delta_s^{agr.} \geq 0) \wedge (\Delta_{mast.} \geq 0)$$

$$I_{mast.} = 0, \text{ if } (\exists r = 1, N'_{trm.}, \Delta_r^{trm.} < 0) \vee (\exists s = 1, N'_{dyn.}, \Delta_s^{agr.} < 0) \vee (\Delta_{mast.} < 0)$$

Here $\Delta_{mast.} = K_{mast.} - K_{mast.}^{thr.}$,
 $\Delta_r^{trm.} = K_r^{trm.} - K_{thr.r}^{trm.}$, $\Delta_s^{agr.} = K_s^{agr.} - K_{thr.s}^{agr.}$,
 where $K_{mast.}^{thr.}$, $K_{thr.r}^{trm.}$, $K_{thr.s}^{agr.}$ are the threshold values of the mastery coefficients determined in block 1.

Since the generated skill means learning execution of the technological operation at a given level of quality up to the automatism, a parameter

$\Delta_{scl.} = N_{succ.} - N_{scl.}$ is also calculated in block 4, where $N_{succ.}$ is the number of succeeded ($I_{mast.} = 1$) successive exercise executions with a given set of indicators, $N_{scl.}$ the minimum number of such executions in which the skill is considered formed, defined in block 1.

In block 5, the controls formation (decision making) $v_{dec.} = f_{dec.}(I_{mast.}, \Delta_{scl.})$ is carried out at the end of each and before the first exercise in case of necessity of: re-execution; modification of the measured quality indicators set; the determination of advisory influences subset in the repeated exercise execution.

To represent the logic-time features of $v_{dec.}$ controls generation with repeated execution of the exercises to form sensorimotor skills, an imitation model was constructed in the form of the Petri Net (Figure 2).

The use of the Petri network allows describing formalized decision-making algorithm (represented by the network positions) in order to organize the most effective information support for the learner, depending on the current skill level (determined by the conditions in the network transitions) [9].

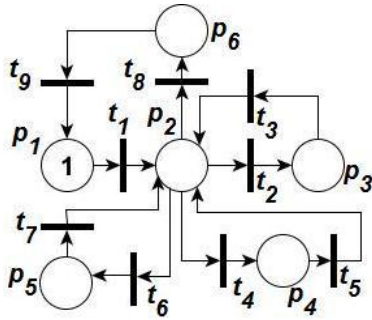

Figure 2: Petri Net.

Positions p_1 correspond to the initial subset formation of quality indicators that are evaluated when the exercise is performed, p_2 – the exercise is performed by the trainees. The position p_3 indicates the decision to repeat the exercise without modifying the subset of the indicators and introducing recommendations, p_4 – without modifying the subset of the indicators and without introducing recommendations, p_5 – with the modification of the

subset of the indicators, p_6 – moving to the next exercise (selected in block 6).

Transition t_1 means that the trainee has started the first exercise, transitions t_3, t_5, t_7 mean that the trainee has started re-execution. The transition to the next exercise is designated as t_9 . Transition t_2 means that the exercise is completed with the condition $I_{mast.} = 0$, t_4 – with the condition $(I_{mast.} = 1) \wedge (\Delta_{scl.} < 0)$, t_6 – with the condition $(I_{mast.} = 1) \wedge (\Delta_{scl.} = 0) \wedge (I_{qual.} = 1)$, t_8 – with the condition $(I_{mast.} = 1) \wedge (\Delta_{scl.} = 0) \wedge (I_{qual.} = 0)$, where $I_{qual.}$ is the indicator of availability ($I_{qual.} = 1$) or absence ($I_{qual.} = 0$) of quality parameters not yet used in successive exercises.

Modification of quality indicators subset is carried out in block 5 according to the dependencies

$$X''_{qual.} = X'_{qual.} \cup X_{qual.}^{new},$$

$$X_{qual.}^{new} = f(X_{qual.} \setminus X'_{qual.}, M_{pr.}),$$

where $X'_{qual.}$ – the current subset of used indicators (initially $X'_{qual.} = \emptyset$), $X''_{qual.}$ – the modified subset, $X_{qual.}^{new}$ – the subset of indicators with the highest priority among those not yet used, $M_{pr.} = \{W_i^{pr.} \mid i = 1, N_{qual.}\}$ – the set of indicators priorities calculated by the hierarchy analysis method in block 1.

A set of recommendations $M_{rec.}$ for re-executing the exercise is defined as

$$M_{rec.} = M_{rec.}^{mast.} \cup M_{rec.}^{exp.} \cup M_{rec.}^{trm.} \cup M_{rec.}^{dyn.},$$

$$\text{where: } M_{rec.}^{mast.} = f_{rec.}^{mast.}(K_{mast.}, K_{mast.}^{thr.});$$

$$M_{rec.}^{exp.} = f_{rec.}^{exp.}(K_{mast.}, K_{mast.}^{exp.}), \text{ where}$$

$$K_{mast.}^{exp.} = f_{exp.}(\gamma_{scl.}, N_{imp.});$$

$$M_{rec.}^{trm.} = \{M_{rec.r}^{trm.} \mid r = 1, N'_{trm.}\}, \text{ where}$$

$$M_{rec.r}^{trm.} = f_{rec.}^{trm.}(K_r^{trm.}, K_{thr.r}^{trm.});$$

$$M_{rec.}^{dyn.} = \{M_{rec.s}^{dyn.} \mid s = 1, N'_{dyn.}\}, \text{ where}$$

$$M_{rec.s}^{dyn.} = f_{rec.}^{dyn.}(K_s^{agr.}, K_{thr.s}^{dyn.}).$$

Here $\gamma_{scl.}$ is the recommended rate of skill formation (learning speed) that determines the planned trajectory of increasing the integral quality score when repeating the exercise and calculated in block 1 by the formulas:

$$\gamma_{scl.} = -\ln(1 - K_{mast.}^{thr.}) / N_{scl.} \quad (\text{at } K_{mast.}^{thr.} < 1) \text{ or}$$

$$\gamma_{scl.} = -\ln(1 - K_{mast.}^{thr.} + \varepsilon_{mast.}^{thr.}) / N_{scl.} \quad (\text{at}$$

$K_{mast.}^{thr.} = 1$), where $\varepsilon_{mast.}^{thr.} \in [0;1]$ is the permissible deviation from $K_{mast.}^{thr.}$ while calculating $\gamma_{scl.}$.

In block 5, after exercise completion $K_{mast.}^{exp.} = 1 - e^{-\gamma_{scl.} N_{imp.}}$ value of the integral quality index is calculated, which must be achieved after performing the exercise $N_{imp.}$ times and necessary to determine the deviation of the actual integral quality index change trajectory from the calculated one. The type and values of the learning curve parameters for the calculation $K_{mast.}^{exp.}$ can be changed based on the accumulated statistics on the operators learning outcomes using data mining techniques.

In block 8, the generation of recommendations (advisory influences) $v_{rec.}(t_z)$ in the exercise execution is made according to the dependence $v_{rec.}(t_z) = f_{rec.}(\Delta_{sit.}(t_z), T_{pl.}, M'_{rec.})$, where $M'_{rec.}$ – a set of possible recommendations, $M_{rec.} \subseteq M'_{rec.}$ – recommendations based on the results of the previous execution, $\Delta_{sit.}(t_z)$ – the deviation of the exercise (obtained in block 7) from the calculated trajectory $T_{pl.}$. Recommendations are signals indicating various modalities (tactile, audible, visual) about the moments when learner's motor actions performed, which are fed to one of the less loaded analyzers.

The mathematical model of the control system served as the basis for the architecture of TSC for the portal crane operators, functional and non-functional requirements for the software of the CTS, database structures [7, 10]. The difference of the created TSC architecture is the availability of software modules that provide the collection and processing of data on the formation of sensorimotor skills among operators.

4 EXPERIMENT

A training course for the practice of portal crane operators has been created, including a set of exercises for AnyCrane to acquire a necessary sensorimotor skills set. The training course includes exercises for improving the lifting controlling and load lowering skills, exercises for testing skills of cargo transfer controlling by changing the angle of jib rotation etc.

Each exercise in AnyCrane is implemented in the form of training tasks sequence. For the learning task, the actions performed by the learner and the observed results of actions are determined.

An experiment was conducted to prove the effectiveness of TSC application as a mean to effectively form professional sensorimotor skills.

There are two groups of trainees: experimental and control, 20 people each. Both groups successfully passed the knowledge testing at the end of the theoretical course.

The first (control) group was trained at the TSC, in which the sensorimotor skills management system was not implemented. The second (experimental) group was trained at TSC with a management system implemented in the form of program modules.

At the end of the training practical stage, during the experiment, each of the trainees moved cargo 5 times. Thus, in each group, 100 cargo transfers were carried out during control exercise execution at the TSC.

The following indicators to evaluate the performance of trainees were used:

- time taken for performing the technological operation, in seconds;
- cargo installation accuracy (cargo deviation relative to the special platform center), in percent of the platform radius;
- smoothness of the crane jib turn (angle of the load deviation from the vertical axis of the jib), in degrees.

Even under unchanged external conditions operator obviously cannot repeat exactly his actions several times in a row. We can say that the operator action with each control is random to a certain extent. Consequently, the operator quality and efficiency can only be estimated on average statistical data, and experiments under the same conditions must be repeated many times [10].

Therefore, for each of the three indicators listed above, the following data were obtained:

$x = (x_1, x_2, x_3, \dots, x_{100})$ – sample for the

experimental group, $y = (y_1, y_2, y_3, \dots, y_{100})$ –

sample for the control group, where x_i ($i = \overline{1,100}$) and y_j ($j = \overline{1,100}$) are the sampling elements, i.e. values obtained during the experiment.

To justify the difference in the control and experimental groups states, we use the Cramer-Welch statistical criterion, since the data are measured in the ratio scale.

The empirical value of the Cramer-Welch criterion is calculated on the basis of information about volumes M and N , values x and y , means \bar{x} and \bar{y} , variances D_x and D_y of compared samples for each of the three indicators by the

formula $T_{emp.} = \frac{\sqrt{M \cdot N} |\bar{x} - \bar{y}|}{\sqrt{M \cdot D_x + N \cdot D_y}}$. The results

of calculations are presented in table 1.

Table 1: Results of the experiment.

Calculated value	First group	Second group
Time of the operation performing, s		
Average	61,2	49,5
Dispersion	90,8	30,9
$T_{emp.}$	10,53	
Accuracy of cargo installation, %		
Average	12,6	8,8
Dispersion	14,9	9,2
$T_{emp.}$	7,86	
Smoothness of the jib rotation, °		
Average	16,9	10,9
Dispersion	19,7	8,0
$T_{emp.}$	11,38	

As we can see in Table 1, the time of cargo transfer technological operation was reduced by 19%, the accuracy of the cargo installation increased by 30% and the smoothness of the crane turning increased by 36%.

The calculated value of the criterion in each case is $T_{emp.} > 1,96$, so the reliability of differences in the characteristics of the control and experimental groups after the end of the experiment is 95%. It can be concluded that the effect of changes follows from the usage of developed by the TSC with the appropriate software modules of a sensory-motor skills management system in the training process.

5 CONCLUSIONS

The most significant results of the study are:

- A mathematical model of the automated control system for developing the professional sensorimotor skills in operators of technological processes was developed. The model differs from the known ones by using new parameters when determining the control actions, taking into account repetitions of exercises, provides the necessary level of information support for the trainee and improves the efficiency of acquiring the ability to self-control the quality of performing technological operations.
- A technique of monitoring and controlling the training process is developed. The technique differs from the existing ones by using the original algorithms for trainees' informational support in the sensorimotor skills formation process.
- Models and approaches were implemented and integrated into the AnyCrane framework.
- The advantage of using TSC with implemented software modules for controlling the sensorimotor skills formation in training portal crane operators has been experimentally shown: the time of performing the load transfer technological operation has decreased by 19%, the cargo installation accuracy has increased by 30% and the smoothness of the crane turning has increased by 36%.

Further possible research in this field:

- improvement of algorithms for assessing the correspondence between the real and calculated trajectories of technological operations execution modeled in the TSC
- a recommender system to provide a trainee with suggestions and information to help him improve his performance.

ACKNOWLEDGMENTS

The research is supported by a stipend of the President of the Russian Federation to young scientists and post-graduate students (No. SP-100.2018.5), which was assigned by the grants Council of the President of the Russian Federation for government support of young Russian scientists and government support for the leading scientific schools of the Russian Federation in 2018-2020.

REFERENCES

- [1] D.A. Novikov, "Collective learning-by-doing", 9th IFAC Symposium on Advances in Control Education (ACE 2012), pp. 408-412, 2012.
- [2] L. Lisitsyna and A. Lyamin, "Approach to development of effective e-learning courses", *Frontiers in Artificial Intelligence and Application*, vol. 262, pp. 732-738, 2014.
- [3] V.M. Dozortsev, "Methods for computer-based operator training as a key element of training systems (present-day trends)", *Automation and Remote Control*, vol. 74(7), pp. 1191-1200, 2013.
- [4] V.M. Dozortsev and V.A. Nazin, "Training of fault diagnosis skills: use of heuristic diagnostic model and technical system simulation", 9th International Industrial Simulation Conference (ISC 2011), pp. 273-278, 2011.
- [5] I. Veshneva, R. Singatulin, A. Bolshakov, T. Chistyakova, L. Melnikov, "Model of formation of the feedback channel within ergatic systems for monitoring of quality of processes of formation of personnel competences", *International Journal for Quality Research*, vol. 9(3), pp. 495-512, 2015.
- [6] D. Bouhnik and G. Carmi, "E-learning Environments in Academy: Technology, Pedagogy and Thinking Dispositions", *Journal of Information Technology Education: Research*, vol. 11, pp. 201-219, 2012.
- [7] R.A. Fayzrakhmanov, I.S. Polevshchikov, A.F. Khabibulin, F.I. Shklyae and R.R. Fayzrakhmanov, "ANYCRANE: Towards a better Port Crane Simulator for Training Operators", *Proc. of the 15th International Industrial Simulation Conference (ISC'2017)*, Warsaw (Poland), pp. 85-87, 31 May – 1 June 2017.
- [8] S.O. Azarkasb, "An Efficient Intrusion Detection System Based on Fuzzy Genetic approaches", *Life Science Journal*, vol. 10(8s), pp. 6-21, 2013.
- [9] Sayed Taha Mohamed, Mohamed Abdel Gawad Mostafa and Ahmed Fathi Mohamed, "A comparative study on Petri Nets in manufacturing applications", *Life Science Journal*, vol. 10(1), pp. 1496-1502, 2013.
- [10] R. Fayzrakhmanov, I. Polevshchikov and A. Khabibulin, "Computer Simulation Complex for Training Operators of Handling Processes", *Proc. of the 5th International Conference on Applied Innovations in IT (ICAIIIT)*, Koethen (Germany), vol. 5, pp. 81-86, 16 March 2017.