

# **Modulation of social and emotional behaviors by Glutamic acid decarboxylase (GAD) and phytoestrogens.**

**Dissertation  
zur Erlangung des akademischen Grades**

**doctor rerum naturalium  
(Dr. rer. nat.)**

**genehmigt durch die Fakultät für Naturwissenschaften  
der Otto-Von-Guerike-Universität Magdeburg**

am 20. Mai. 2014

Verteidigung am

von: MSc., MSc. Kiran Veer Kaur Sandhu  
geb. am 07.12.1982 in Malout, India

Gutachter: Prof. Dr. sc. Oliver Stork

Prof. Dr. med. Gabriele M. Rune

eingereichte Dissertation

18. Dezember. 2014

*“If the human brain were so simple we could understand it, we would be so simple that we couldn’t..”*

*-Emerson M Pugh*

*-Dedicated to my parents-*

## **Acknowledgement**

A very special thanks to Prof. Dr. Oliver Stork, who gave me the opportunity to pursue my dream. I want to thank you for doing multitasking so well (being supervisor, friend, family, philosopher) and always being there for me always.

I would like to thank Simone Stork both for her excellent technical assistance and taking care of me as a family member. Thanks for the warmth and love you share, that I never felt that I am far away from home. I like to thank Franziska Weber and Antje for their excellent technical assistance and constant support. I would like to thank Angel Deter and Theresa Nawrath for animal care and for their assistance. I worked a lot with animals and it was with their excellent work it had been possible.

I particularly wish to emphasize here Dr. rer. nat. Kati Rehberg, Daniel Lang and Iris Mueller for their constant support, advice and assistance in writing this thesis and also for lending their ears to me. I want to thank Deniz Ashan M. and Ahzan Raza for being there as friends and for stimulating my neurons with new ideas and projects. In general I would like to thank the entire working group of the Department of Genetics and Molecular Neurobiology for their corporation in a friendly and stimulating atmosphere.

I would like to thank my flatmate Sinthya Ahmed who has been patient and helped me a lot during the course of my writing.

A big thanks and hug to my family who had always been there for me and survived my every mood swing. I want to thank my dad and mom especially for always believing in me and never giving up on me. I want to especially thank my brother who always stood by me as a best friend with all odds.

In the end to all people in science who inspire me every day to make a new quest every day.

**Statement of interest - Erklärung**

Ich erkläre, dass ich die von mir eingereichte Dissertation zum dem Thema der Medizinischen Fakultät der Otto-von-Guericke-Universität zur Promotion eingereichte Dissertation mit dem Titel

„Modulation of social and emotional behaviors by  
Glutamic acid decarboxylase (GAD) and phytoestrogens.“

im Institut für Biologie der Fakultät für Naturwissenschaften

selbständig verfasst, nicht schon als Dissertation verwendet habe und die benutzten Hilfsmittel und Quellen vollständig angegeben wurden.

Weiterhin erkläre ich, dass ich weder diese noch eine andere Arbeit zur Erlangung des akademischen Grades doctor rerum naturalium (Dr. rer. nat.) an anderen Einrichtungen eingereicht habe.

Magdeburg, den 15.01.2015.



Kiran Veer Kaur Sandhu

## **Zusammenfassung**

Die Glutamat-Decarboxylase GAD bestimmt mit der Reaktionsgeschwindigkeit seiner Enzymaktivität die Umwandlung von Glutamat zu GABA, einem inhibitorischen Neurotransmitter im zentralen Nervensystem. Reduzierte Expressionsniveaus von GAD werden mit einer Vielzahl von psychiatrischen Störungen wie Schizophrenie, Autismus und bipolarer Störung assoziiert. Viele psychiatrische Störungen sind durch ein soziales Defizit als eines ihrer Hauptmerkmale gekennzeichnet. Daher adressierte ich in meiner Studie die Rolle von GAD und Phytoestrogenen in der Regulierung sozialen Verhaltens und wie Phytoestrogene GAD 67 und 65 Expressionsniveaus in verschiedenen Subregionen der Amygdala beeinflussen. Im ersten Abschnitt meiner Studie berichte ich von Störungen im sozialen Verhalten bei haplodefizienten, männlichen GAD67<sup>+/-</sup> Mäusen. GAD67<sup>+/-</sup> Mäuse zeigten gegenüber Kontrolltieren aus der selben Aufzucht reduziertes Sozialverhalten, welches durch gedämpft-aggressives Territorialverhalten begleitet wurde. Angeborene Verhaltensweisen wie Nestbau, Urinmarkierung und Angstreaktionen blieben hingegen in diesen Mäusen unverändert. Darüber hinaus trat bei ihnen eine zwei Stunden verzögerte Phasenverschiebung während der Messung der Heimkäfigaktivität auf. Zudem zeigten GAD67<sup>+/-</sup> Mäuse bei der Auswahl zwischen sozialem und nichtsozialem Geruch gegenüber Kontrollmäusen aus der selben Aufzucht eine Tendenz hin zu nichtsozialem Geruch. In einem Geruchs-Sensitivitätstest zeigten GAD67<sup>+/-</sup> Mäuse hingegen sowohl eine reduzierte Geruchssensitivität gegenüber sozialen, als auch nichtsozialen Gerüchen. Dies weist auf eine Störung in der Wahrnehmung und dem Verarbeitung von sozial relevanten olfaktorischen Stimuli hin. Die immunhistochemische Detektion von c-Fos in für Sozialverhalten relevanten Gehirnregionen nach sozialer Interaktion zeigte bei GAD67<sup>+/-</sup> Mäusen eine reduzierte Aktivität im lateralen Septum, im medialen preoptischen Areal, dem Nucleus striae terminalis, sowie der kortikalen und medialen Amygdala. Dies weist darauf hin, dass GAD 67 in der Vermittlung sozialen Verhaltens beteiligt ist.

GAD wurde mit einer Reihe von Modulatoren in Verbindung gebracht. Eine dieser Modulatoren ist Phytoestrogen. Phytoestrogene sind pflanzlichen Ursprungs und ein Analogon zu Östrogen. Östrogene wurden mit der Transkriptions- und

Translationsregulation von GAD assoziiert. Daher konnte ich mit der chronischen Verabreichung von Phytoestrogenen (phyto150) als Diät im zweiten Kapitel zeigen, wie der Verlust von Phytoestrogen (phyto0) gleich einer eingeschränkten GAD67-Verfügbarkeit soziale Defizite hervorruft. Mäuse mit phyto0-Diät zeigten reduziertes Sozialverhalten in sozialen Interaktionsexperimenten. Während des Aggressionstests zeigten diese gedämpft-aggressives Antwortverhalten gegenüber Eindringlingen mit steigender Latenzzeit einen Angriff zu initiieren, oder überhaupt nicht anzugreifen. Darüber hinaus zeigten sie anogenitales Schnüffeln und Verzögerungen im ersten Kontakt mit Eindringlingen. Dies weist auf eine Fehlfunktion der olfaktorischen und sozialen Verarbeitungseinheiten hin. Darüber hinaus zeigten die phyto0-behandelten Mäuse signifikant weniger Interesse an sozialen Gerüchen, vorallem weiblichen Gerüchen oder Pheromone für nichtsoziale Gerüche, wenn ihnen die Wahl zwischen sozialen und nichtsozialen Gerüchen geboten wurde. Ich konnte hierbei eine ähnlich reduzierte Aktivierung wie in jenen phyto0 behandelten GAD 67<sup>+/-</sup> Mäusen im lateralen Septum, dem medialen preoptischen Areal, dem Nucleus striae terminalis, sowie der kortikalen und medialen Amygdala feststellen, die sozialen Interaktionsexperimenten ausgesetzt waren. Die Daten lassen daher vermuten, dass die Abwesenheit von Phytoestrogenen jene sozialen Defizite imitiert, die auch in GAD 67<sup>+/-</sup> Mäusen beobachtet wurden.

Im letzten Teil meiner Arbeit zeigte ich die Regulierung von Phytoestrogenen bei der Expression von GAD in unterschiedlichen Subregionen der Amygdala. Zunächst konnte ich bei GAD67-GFP (green fluorescence protein) knock-in Mäusen mit einer phyto150 Diät einen signifikanten Anstieg der GAD 67-Promotor gesteuerten GFP-Expression in unterschiedlichen Subarealen der Amygdala beobachten. Ein ähnlicher Anstieg wurde bei der Quantifizierung einzelner Zellen festgestellt. Hochauflösende Mikrodisektion von unterschiedlichen Regionen zeigte einen Expressions-Anstieg von GAD 67 und 65 in der lateralen und basolateralen Amygdala. Die Daten weisen somit auf eine funktionale Rolle von Phytoestrogenen in der Kontrolle der GAD-Expression hin. Ein reduziertes GAD-Niveau wurde mit Furch-Konditionierung assoziiert. In meiner Studie zeigten phyto0-behandelte Mäuse während des Wiederabrufens des auf den Schock-Kontext reduzierten Furchgedächtnisses eine generell gesteigerte Hyperaktivität mit einer generellen Reduzierung im furchbedingten Erstarren. Es lässt vermuten, dass Phytoestrogene in der Regulierung von GAD eine Rolle spielen. Diese Rolle bedarf aber noch der weiteren Erforschung

seiner Mechanismen. Schlussendlich kann gefolgert werden, dass GAD67<sup>+/-</sup> Mäuse ein nützliches Modell sein können, um soziales Verhalten unter neuropsychiatrischen Zuständen zu studieren. Ebenso gilt dies für Phytoestrogene als alternative Behandlung von defizitären GAD67-Zuständen.

Die selbe Tendenz wurde im Geruchs-Sensitivitätstest beobachtet, wo Mäuse auf phyto0-Diät eine reduzierte Präferenz für weibliche Pheromone selbst bei hohen Konzentrationen zeigten. Die weist auf Störungen in der Detektion und Verarbeitung von sozial relevanten olfaktorischen Stimuli hin.

## ***Summary***

Glutamic acid decarboxylase GAD, the rate-limiting enzyme is involved with the synthesis of GABA from glutamate. Reduction of GAD levels has been associated with an onset of various psychiatric conditions. Most of the psychiatric conditions have social deficit as one of the evident symptom. In the first section of my study, I reported disturbance of social behavior in GAD67 haplodeficient male mice compared to the control littermates. The GAD67<sup>+/-</sup> mice showed reduced sociability accompanied with ablated aggressive territorial behavior. Whereas innate behaviors like nest building, urine marking and anxiety measures remained intact in GAD67<sup>+/-</sup> mice. Interestingly, a two hour delay during the phase shift was recorded in GAD67<sup>+/-</sup> mice compared to control littermates during home cage activity measure. Moreover, during the choice between social and non social odor, the GAD67<sup>+/-</sup> mice showed preference for non social odor compared to control littermates. In the odor sensitivity test GAD67<sup>+/-</sup> mice showed reduced sensitivity to both non social and social odor. Thus indicating a disturbance in the detection and processing of socially relevant olfactory stimuli. Immunohistochemical labeling of brain regions associated with social behavior with c-Fos (immediate early gene) post social interaction showed reduced activation of lateral septum, medial preoptic area, bed nucleus of stria terminalis, cortical and medial amygdala in GAD67<sup>+/-</sup> mice. Thus suggesting function of GAD67 in mediation of social behavior.

GAD has been associated with a number of modulators. One such modulator is phytoestrogens. Phytoestrogens, which are of plant origin and are analogous to estrogens. Estrogens have been associated with the regulation of the transcription and translation of GAD expression. Hence in my second chapter with chronic administration of the phytoestrogens (phyto150) in the diet, I showed how the depletion of the phytoestrogens (phyto0) mimics a condition of GAD67 deficit state, resulting in social behavior dysruption. Mice on phyto0 diet showed reduced sociability in the social interaction paradigm. During the aggression test they displayed ablated aggressive response towards the intruder with increase latency to initiate an attack or fail to attack the intruder. Moreover, they showed increase anogenital sniffing and delay in making first contact with the intruder mice. Thus



indicating dysfunction of olfactory and social processing unit. Furthermore, when offered a choice between non social odor and social odor phyto0 treated mice showed significant reduction for social odor especially with female odor or pheromone to non social odors. Similar trend was observed in odor sensitivity test where the mice on phyto0 diet showed reduced preference for female pheromone even at higher concentration, indication a disturbance in the detection and processing of socially relevant olfactory stimuli.

Indeed I observed similar reduced neuronal activation in the lateral septum, medial preoptic area, bed nucleus of stria terminalis, both cortical and medial amygdala with phyto0 treated mice exposed to social interaction paradigm as previously observed in GAD67<sup>+/-</sup> mice. Thus suggesting phytoestrogens free conditions mimics social deficits in male mice as observed during GAD67 reduced condition. In the last part of my work I reported change in the GAD67 and GAD65 expression levels in different subregions of the amygdala. GFP (green fluorescence protein) quantification in GAD67-GFP knock-in mice on the two diets showed significant increase in GAD67 activity both at region and individual cell level per amygdala subregion. Microdissection of different regions of amygdala showed increase in expression of both GAD67 and 65 in the lateral and basolateral amygdala. The data thus suggest functional role of phytoestrogens in mediation of GAD67 expression especially. Deficit in the GAD levels has been associated with fear conditioning. In my study, phyto0 treated mice showed an overall increase in hyperactivity resulting in an overall reduction in freezing during retrieval limited to the shock context. Thus suggesting phytoestrogens to modulate GAD function, but still one needs to further dissect its mechanism. Overall my study suggests GAD67<sup>+/-</sup> as a useful model to study social behavior in neuropsychiatric condition and phytoestrogens as a possible treatment to ameliorate GAD67 deficit condition.

---

**Index**

|  |           |
|--|-----------|
| <b>1. Introduction</b>   | <b>1</b>  |
| <b>1.1. Glutamic acid decarboxylase (GAD)</b>  | <b>3</b>  |
| <b>1.2. GABA (<math>\gamma</math>-amino-butyric acid), the neurotransmitter</b>                              | <b>5</b>  |
| <b>1.3. GAD and GABA related function: memory consolidation, circadian regulation and social interaction</b> | <b>8</b>  |
| <b>1.4. Deficits in GABA/ GAD levels in psychiatric disorders</b>  | <b>12</b> |
| <b>1.5. Estrogens as a modulator of GABA/GAD</b>   | <b>14</b> |
| <b>1.6. Phytoestrogens role players for estrogens</b>  | <b>16</b> |
| <br>   |           |
| <b>2. Hypothesis</b>   | <b>21</b> |
| <br>   |           |
| <b>3. Methods</b>  | <b>24</b> |
| <b>3.1. Animal experiment</b>  | <b>24</b> |
| <b>3.1.1. Animal housing</b>   | <b>24</b> |
| <b>3.1.2. Animal diet</b>  | <b>24</b> |
| <b>3.1.3. Animal welfare</b>   | <b>25</b> |
| <b>3.1.4. Animal strains</b>   | <b>25</b> |
| <b>3.1.4.1. GAD67-GFP mice</b>   | <b>25</b> |
| <b>3.1.4.2. GAD65 mice</b>   | <b>26</b> |
| <b>3.1.5. GAD67 and 65 genotyping</b>  | <b>26</b> |
| <b>3.1.5.1. DNA extraction for genotyping</b>  | <b>26</b> |
| <b>3.1.5.2. Polymerase chain reaction for genotyping</b>   | <b>26</b> |
| <b>3.1.5.2.1. GAD67 DNA PCR</b>  | <b>27</b> |
| <b>3.1.5.2.2. GAD65 DNA PCR</b>  | <b>28</b> |
| <b>3.1.3. Gel electrophoresis</b>  | <b>30</b> |
| <b>3.2. Animal behavior</b>  | <b>31</b> |
| <b>3.2.1. Anxiety assays</b>   | <b>31</b> |
| <b>3.2.1.1. Open field test</b>  | <b>31</b> |
| <b>3.2.1.2. Light and dark avoidance test</b>  | <b>31</b> |
| <b>3.2.1.3. Marble burying test (repetitive behavior)</b>  | <b>32</b> |
| <b>3.2.2. Social interaction paradigm</b>  | <b>32</b> |
| <b>3.2.2.1. One-interaction partner test</b>   | <b>33</b> |

---

|  |    |
|--|----|
| 3.2.2.2. Male and female interaction test  | 35 |
| 3.2.3. Olfactory test  | 35 |
| 3.2.3.1. Non-social sensitivity test   | 35 |
| 3.2.4. Pheromone sensitivity test  | 37 |
| 3.2.5. Social odor and non-social odor test/male vs.<br>female bedding odor test | 38 |
| 3.2.6. Aggression test   | 38 |
| 3.2.6.1. Resident intruder aggression test                                       | 38 |
| 3.2.7. Nest buildings  | 40 |
| 3.2.8. Fear memory test  | 41 |
| 3.2.8.1. Neutral context   | 42 |
| 3.2.8.2. Shock context   | 42 |
| 3.2.9. Home cage activity  | 43 |
| 3.2.10. Urine marking test   | 43 |
| 3.3. Immunohistochemistry  | 44 |
| 3.3.1. Perfusion of the adult mouse  | 44 |
| 3.3.2. Preparation of cryo-section   | 44 |
| 3.3.3. Preparation of GFP quantification   | 45 |
| 3.3.4. Single cell GFP quantification  | 45 |
| 3.3.5. c-FOS immunohistochemistry staining                                       | 46 |
| 3.4. Brain tissue laser-capture  | 48 |
| 3.4.1. Preparation of the PLL coated glass slides                                | 48 |
| 3.4.2. Preparation to freeze fresh brain tissue capture                          | 48 |
| 3.4.3. Preparation of the cryostat section for laser-capture                     | 48 |
| 3.4.4. Tissue mRNA fixed for laser capture                                       | 49 |
| 3.4.5. Parameters for micro-dissection   | 49 |
| 3.4.6. Protocol for mRNA extraction and reverse transcriptase                    | 50 |
| 3.4.7. Real time PCR protocol  | 51 |
| 3.4.8. Calculation and analysis  | 53 |
| 3.5. ELISA quantification  | 53 |
| 3.5.1. Serum preparation from the blood plasma                                   | 54 |
| 3.5.2. Estrogen ELISA measurement protocol                                       | 54 |
| 3.5.3. Testosterone ELISA measurement protocol                                   | 55 |
| 3.5.4. Vasopressin ELISA measurement protocol                                    | 57 |

---

|   |           |
|---|-----------|
| <b>3.6. Scoring</b>   | <b>59</b> |
| <br>  |           |
| <b>Chapter 1</b>  |           |
| <b>Social deficits and ablated aggressive behavior in GAD67<br/>haplodeficient male mice</b>                              | <b>60</b> |
| <b>4.1. Introduction</b>  | <b>61</b> |
| <b>4.2. Experiment design</b>   | <b>62</b> |
| <b>4.3. Result</b>  | <b>66</b> |
| <b>4.3.1. Reduced social affiliation in GAD67<sup>+/-</sup> mice</b>  | <b>66</b> |
| <b>4.3.2. Lack of social odor preference in GAD67<sup>+/-</sup> mice</b>  | <b>68</b> |
| <b>4.3.3. Reduced aggressive behavior of GAD67<sup>+/-</sup> mice</b>   | <b>70</b> |
| <b>4.3.4. Unaltered nest building of GAD67<sup>+/-</sup> mice</b>   | <b>72</b> |
| <b>4.3.5. Unaltered urine marking in the GAD67<sup>+/-</sup> mice</b>   | <b>73</b> |
| <b>4.3.6. Delayed diurnal rhythm of GAD67<sup>+/-</sup> mice</b>  | <b>74</b> |
| <b>4.3.7. Exploratory and anxiety-like behavior of GAD67<sup>+/-</sup> mice</b>   | <b>75</b> |
| <b>4.3.8. No change in marble burying test</b>  | <b>76</b> |
| <b>4.3.9. Increase odor sensitivity at higher concentration by<br/>        GAD67<sup>+/-</sup> mice</b>                   | <b>77</b> |
| <b>4.3.10. Altered c-Fos expression in the different subregions<br/>        associated with social interaction</b>        | <b>79</b> |
| <b>4.3.11. Normal testosterone and vasopressin concentrations<br/>        in GAD67<sup>+/-</sup> mice</b>                 | <b>82</b> |
| <b>4.4. Discussion</b>  | <b>84</b> |
| <br>  |           |
| <b>Chapter 2</b>  |           |
| <b>Phytoestrogens mediated alteration in social-pheromone association<br/>and ablated aggression in C57Bl/6 male mice</b> | <b>90</b> |
| <b>5.1. Introduction</b>  | <b>91</b> |
| <b>5.2. Experiment design</b>   | <b>94</b> |
| <b>5.3. Result</b>  | <b>96</b> |

---

|  |     |
|--|-----|
| 5.3.1. Decrease in preference for social interaction with phyto0 treatment   | 96  |
| 5.3.2. Impaired inclination for social odor on phyto0 diet   | 98  |
| 5.3.3. Attrition of aggression by phyto0   | 100 |
| 5.3.4. Nest building behavior remain intact between the two diet   | 102 |
| 5.3.5. Altered urine markings in phyto0 treated mice   | 103 |
| 5.3.6. Delayed diurnal rhythm in C57Bl/6 mice on phyto0 diet   | 104 |
| 5.3.7. Increase odor sensitivity at higher concentration by phyto0 treated mice  | 105 |
| 5.3.7. Testosterone and 17 $\beta$ -estradiol remained unchanged between the diets   | 107 |
| 5.3.8. Normal vasopressin concentrations between the two diets   | 108 |
| 5.3.9. Change in c-Fos expression in subregions associated with social interaction with phyto0 diet                            | 109 |
| 5.4. Discussion  | 113 |
| <br>   |     |
| <b>Chapter 3</b>   |     |
| <b>Phytoestrogen mediated modulation of Glutamic acid decarboxylase gene expression in the amygdala</b>                        |     |
|  | 119 |
| 6.1. Introduction  | 120 |
| 6.2. Experiment design   | 122 |
| 6.3. Result  | 123 |
| 6.3.1. Increased GFP expression in different subregions of amygdala in GAD67-GFP mice on phyto150 diet compared to phyto0 diet | 123 |
| 6.3.2. Altered mRNA expression in different subregions of the amygdala with the two diets                                      | 125 |
| 6.3.4 Anxiolytic effect mediated by the phytoestrogen mice   | 127 |

|   |            |
|---|------------|
| <b>6.3.3 Reduction in overall freezing response and increase<br/>hyperactivity response to shock context in Pavlovian fear<br/>memory paradigm with phyto0 diet</b> | <b>129</b> |
| <b>6.4. Discussion</b>  | <b>134</b> |
| <b>7. Conclusion</b>  | <b>139</b> |
| <b>8. Future direction</b>  | <b>143</b> |
| <b>9. Bibliography</b>  | <b>145</b> |
| <b>10. Curriculum vitae</b>   | <b>190</b> |
| <b>11. Publications list</b>  | <b>191</b> |
| <b>12. Appendix</b>   | <b>192</b> |
| <b>A.1. Reagents, Solution</b>  | <b>192</b> |
| <b>A.2. Antibodies</b>  | <b>193</b> |
| <b>A.3. Real time expression assay</b>  | <b>194</b> |
| <b>A.4. DNA length marker</b>   | <b>194</b> |
| <b>A.5. Kits</b>  | <b>194</b> |
| <b>A.6. Software</b>  | <b>195</b> |
| <b>A.7. Chemicals</b>   | <b>195</b> |
| <b>A.8. Instruments and consumable</b>  | <b>196</b> |

\*\*\*\*\*

**Abbreviations**

|                    |   |
|--------------------|---|
| A                  | Adenine                                     |
| AKT                | v-akt murine thymoma viral oncogene homolog |
| ANOVA              | Analysis of Variance                        |
| AOB                | Accessory olfactory bulb                    |
| Arg                | Arginine                                    |
| BDNF               | Brain derived neurotrophic factors          |
| BLA                | Basolateral amygdala                        |
| BNsT               | Bed nucleus stria terminalis                |
| bp                 | Base pairs                                  |
| $\beta$            | Beta  |
| C                  | Cytosine                                    |
| $^{\circ}\text{C}$ | Degree Celsius                              |
| CA1                | Cornu ammonis 1                             |
| CA3                | Cornu ammonis 3                             |
| cAMP               | Cyclic adenosine monophosphate              |
| cDNA               | copy DNA                                    |
| CeA                | Central amygdala                            |
| cm                 | centimeter                                  |
| CNS                | Central nervous system                      |
| CeA                | Central nuclei of amygdala                  |
| CoA                | Cortical nuclei of amygdala                 |
| CS                 | Conditioned stimuli                         |
| CS+                | Unconditioned stimuli                       |
| CS-                | Conditioned stimuli                         |
| CT                 | Cycle threshold                             |
| Ctxt               | Context                                     |
| DAPI               | 4',6-diamidino-2-phenylindole               |
| dB                 | Decibel                                     |
| dCT                | delta-CT                                    |
| ddCT               | delta-delta-CT                              |
| DD                 | doubled distilled                           |
| DG                 | Dentate Gyrus                               |

|        |  |
|--------|--|
| DHT    | Dihydrotestosterone                              |
| DMDC   | Dimethyl dicarbonate                             |
| DMSO   | Dimethyl sulfoxide                               |
| DNA    | Deoxyribonucleic acid                            |
| dNTP   | Deoxy-nucleotide                                 |
| e.g.   | for example (from latin: <i>exempli gratia</i> ) |
| ELISA  | Enzyme linked immunosorbent assay                |
| ER     | Estrogen receptor                                |
| ERE    | Estrogen response elements                       |
| ERT    | Estrogen replacement therapy                     |
| ERK    | Extracellular signal-regulated kinase            |
| F      | Factor   |
| Fig.   | Figure   |
| G      | Guanine  |
| GAD    | Glutamic acid decarboxylase                      |
| GABA   | Gamma amino butyric acid                         |
| GABA-T | GABA transaminase                                |
| GAT    | GABA transporter                                 |
| GC     | Granular cells                                   |
| GFP    | green fluorescence protein                       |
| GL     | Glomerulus                                       |
| Gln    | Glutamine  |
| Glu    | Glutamate  |
| H      | hour   |
| HRT    | Hormone replacement therapy                      |
| i.e.   | that is (from latin <i>id est</i> )              |
| ISI    | Inter-stimulus-interval                          |
| kb     | Kilobase   |
| kDa    | Kilodalton                                       |
| kg     | Kilogram (1000 gram)                             |
| kHz    | Kilohertz ( $10^3$ Hz)                           |
| L      | liter  |
| LA     | Lateral amygdala                                 |
| LCM    | Laser-capture microdissection                    |



|                   |  |
|-------------------|--|
| LSD               | Lateral septum dorsal                              |
| LTP               | Long term potentiation                             |
| M                 | Molar  |
| mA                | Milli-Ampere ( $10^{-3}$ A)                        |
| nm                | nano molar   |
| MANOVA            | Multiple Analysis of Variance                      |
| MAP               | Mitogen-activated protein                          |
| MeA               | Medial amygdala                                    |
| MgCl <sub>2</sub> | Magnesium chloride                                 |
| MPOA              | Medial preoptic area                               |
| mRNA              | Messenger RNA                                      |
| n                 | number   |
| NA                | Not applicable                                     |
| NC                | Neutral context                                    |
| NPY               | Neuropeptide Y                                     |
| n.s.              | non-significant                                    |
| ng                | nanogram ( $10^{-9}$ gram)                         |
| μL                | micro liter ( $10^{-6}$ liter)                     |
| μL                | micro gram ( $10^{-6}$ gram)                       |
| mL                | milliliter ( $10^{-3}$ liter)                      |
| mg                | milligram ( $10^{-3}$ gram)                        |
| min               | minute   |
| mM                | Milli-Molar  |
| mRNA              | messenger RNA                                      |
| n                 | number of animals/ samples uses                    |
| NC                | Neutral context                                    |
| NFQ               | non-fluorescent quencher                           |
| nM                | Nano-Molar   |
| p                 | probability  |
| PACAP             | pituitary adenylate cyclase activating polypeptide |
| PB                | phosphate buffer                                   |
| PCR               | Polymerase chain reaction                          |
| PFA               | paraformaldehyde                                   |
| pg                | pictogram ( $10^{-12}$ gram)                       |

|                |   |
|----------------|---|
| PGK            | Phosphoglycerate kinase                     |
| Phyto          | Phytoestrogens                              |
| PKC $\beta_2$  | Protein kinase C $\beta_2$                  |
| PLC $\gamma$   | Phospholipase C $\gamma$                    |
| PLL            | Poly-L-Lysine                               |
| PPI            | Pre pulse inhibition                        |
| Proteinase K   | Proteinase kinase                           |
| RNA            | Ribonucleic acid                            |
| RNAse          | Ribonuclease                                |
| rpm            | revolution per minute                       |
| RQ             | Relative quantification value               |
| RT             | Real time                                   |
| s              | seconds                                     |
| SC             | Shock context                               |
| sem            | standard error of mean                      |
| siRNA          | small interfering RNA                       |
| SST            | Somatostatin                                |
| T              | Thymine                                     |
| Taq            | <i>Thermos aquaticus</i>                    |
| T <sub>m</sub> | melting temperature                         |
| Typ            | type  |
| U              | Unit  |
| US             | Unconditioned stimulus                      |
| UV             | Ultraviolet                                 |
| VIAAT          | Vesicular inhibitory amino acid transporter |
| Vs             | versus                                      |
| ZT             | zeitgeber                                   |

## **1. Introduction:**

Individual complexity reflects the complexity of the brain, our every action is regulated by our complex brain. The functionality of the brain is attained through the synchrony of excitatory and inhibitory chemicals termed as neurotransmitters. Neurotransmitters mediate the flow of information and the communication among the neurons. The excitatory neurotransmitter (for example: glutamate) carries out the information through the neuron and inhibitory neurotransmitter (for example: GABA:  $\gamma$ -amino-butyric acid) functions like a check mechanism, as they regulate the excitatory neurotransmitter. Excess of either excitatory (Hirose and Chan, 1993; Mark et al., 2001) or inhibitory neurotransmitter interfere with the normal brain function (Bonin and Orser, 2008; Klaueff and Nutt, 2007; Treiman, 2001). Many pathological conditions have been associated with a disturbance in the balance of the neurotransmitter resulting in altered behavior response (Javitt, 2004; Petty and Sherman, 1984).

My research focus has been to further address the modulation and function of the inhibitory neurotransmitter. Studies have shown association of many factors i.e., internal (physiological, hormonal, genetic) and external (stress stimuli, drugs and diet) to modulate the function of the inhibitory neurotransmitter like GABA (Hartman et al., 2007; Herbison and Fenelon, 1995; Mula, 2011; Saito et al., 2010). During my study, I attempted to address the role of diet (a non-invasive approach) in order to study the effect of hormones on the inhibitory neurotransmitter function both at behavior and at molecular level.

My interest in my research stems from my inclination towards addressing the vital question, do phytoestrogens in the diet effect behavior and corresponding neurological function. The consumed diet is a vital source of some essential amino acids, minerals and vitamins. Intensive work is being carried out to investigate the role of diet and its function in aging and disorders (Hirano et al., 2014; Partridge, 2012). One such example is in context to the estrogens therapy which menopausal females undergo to attenuate the post-menopausal symptoms. Studies have shown, that phytoestrogens are a healthy alternative to the synthetic estrogens, thus more patients are switching to phytoestrogens as estrogens supplements (Rice and Whitehead, 2006). Additionally, stroke patients are

recommended soy rich diet (Daidzein and Genistein) to facilitate fast recovery and restoration of new neurons in the affected region (Banecka-Majkutewicz et al., 2012).

Thus, suggesting the role of estrogens as a neuro-protective, neuro-regenerative and an alternative therapy.

Estrogens have been observed to be central in regulating a variety of signal transduction pathways (Marino et al., 2006). One such target mediating transcription and translation of gene by estrogens is glutamic acid decarboxylase (GAD) (Hudgens et al., 2009; Joh et al., 2006). GAD is the rate-limiting enzyme, mediating the synthesis of GABA from glutamate. It has been associated with a number of cognitive behaviors, memory consolidation and psychiatric disorders (Bergado-Acosta et al., 2008; Curley et al., 2011; Guidotti et al., 2000). In my work I tried to address the critical question to further understand the role of estrogens through phytoestrogens (plants source of soy and analogous to estrogens) dietary administration in regulation of behaviors associated with inhibitory transmitter:

Do phytoestrogens effects the behaviors related to GAD function?

If so, what are the different spectra of behavior being influenced?

### 1.1. Glutamic acid decarboxylase (GAD)

GABA is the major fast inhibitory synaptic neurotransmitter in the central nervous system (CNS). Most of the psychiatric disorders are associated with the imbalance between the inhibitory and the excitatory neurotransmitter and thus therapeutic approach attempts to restore this balance. GABA is an amino acid derivative and is synthesized from the excitatory neurotransmitter glutamate by the rate-limiting enzyme, GAD (Fig. 1.) (Brambilla et al., 2003; Peng et al., 1993; Schousboe et al., 1993).

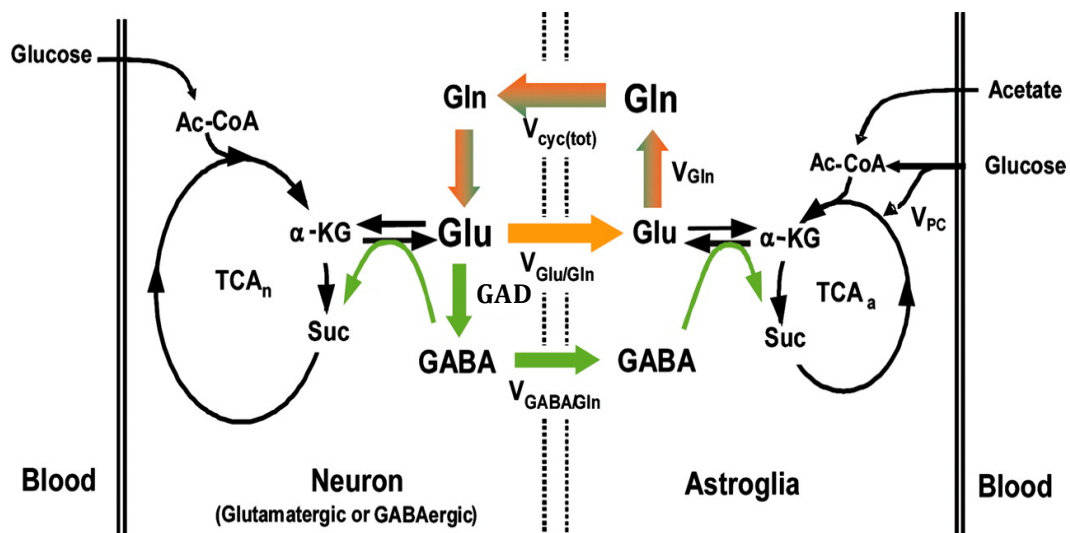

**Fig. 1.** Schematic outline of GABA metabolism from glutamate/glutamine by GAD and cycling between the neurons and glia. Glu (glutamate), Gln (glutamine), GABA ( $\gamma$ -amino-butyric acid) and GAD (glutamate decarboxylic acid)(Patel et al., 2005).

Thus labeling of the cells with the GAD has been one of the most reliable methods to study the GABAergic subpopulation of neurons (Martin et al., 1991; Martin and Rimvall, 1993). Two main types of GAD isoforms have been identified to metabolize GABA, which are called as GAD67 and GAD65. Both isoforms are widely distributed in the brain. GAD67 and 65 are named according to their respective molecular weights of 65, 400 Da and 66, 600 Da (Erlander et al., 1991; Soghomonian and Martin, 1998). The two isoforms display distinct electrophoretic and kinetic characteristics (Karlsen et al., 1991;

Kaufman et al., 1991; Martin and Rimvall, 1993) and are differentially modulated at the transcriptional levels (Pinal et al., 1997; Szabo et al., 1996; Yanagawa et al., 1997). The two isoforms are differentially distributed which is due to their differential membrane interaction (Christgau et al., 1992; Namchuk et al 1997; Shi et al., 1994).

GAD isoforms have been associated with number of functions. GAD65 is known to mediate increased GABA synthesis during enhanced neuronal activity (Patel et al., 2006; Yip et al., 2009). During early prenatal period, dentate nuclei show a stronger labeling for GAD65 compared to GAD67 mRNA (Esclapez et al., 1993; Ji and Obata 1999) in mutant mice with reduced GAD67 levels. However, GABA content was drastically increased in neurites with no developmental deficits in cerebellar Purkinje cells. Thus suggesting GAD65 to play an important role in the rescue of GABA function in a GAD67 deficient system. On the other hand GAD67 is known to tightly regulate the intra-neuronal GABA levels in the CNS and critical for GABAergic function (Yip et al., 2007). Additionally, GAD function is not limited to the neurotransmission, but it also includes role in modulation of cell proliferation and protein metabolism (Qin et al., 1998).

GAD67 and 65 are directly involve with synthesizes of GABA whereas GAD67 is indirectly associated through mitochondrial metabolism to synthesize GABA, (Walls et al., 2011). Studies in rats have shown that administration of vigabatrin<sup>1</sup> for two to four days daily with 30 mg of vigabatrin/kg resulted in reduction of cortical GABA by 70 %, and with protein reduction of GAD67. On the other hand, GAD65 protein level remained unaffected by vigabatrin administration (Manor et al., 1996; Rimvall and Martin, 1994). *In vivo* studies with GAD65 knockout mice revealed that in these mice GAD67 undertook the GAD65 function of synaptic transmission and thus maintaining GABA release at the synaptic end (Kash et al., 1999). Hence the functional association of GABA is more with GAD67 as compared to GAD65. Thus, supporting the central role and association of GAD67 with GABA synthesis and function.

Similarly, GAD67 appears to be more significantly expressed in the mouse brain compared to the rat brain (Esclapez et al., 1994). Immunohistochemical studies have shown that there is 53-49 % more of GAD67 expression in the mouse cerebral cortex and

---

<sup>1</sup> It is an antiepileptic drug and an analog of GABA.

<sup>2</sup> A neurological mechanism in which a weak pre-stimuli (prepulse) inhibits the reaction to a

hippocampus compared to the rat brain where it is limited to 23-18 % (Sheikh et al., 1999). However, the important role of GAD67 in the mouse brain could explain the normal brain levels of GABA in the GAD65 null mutant mice (Asada et al., 1996; Kash et al., 1997; Sheikh et al., 1999). Therefore, more GAD related animal model studies are gaining interest to further address and understand its function.

## 1.2. GABA ( $\gamma$ -amino-butyrac acid), the neurotransmitter

GABA, the key inhibitory neurotransmitter has been associated with different physiological and neurological conditions. GABA receptors have been the target of a wide range of drugs including anticonvulsants, anxiolytics and sedatives (McKernan et al., 2000; Zheleznova et al., 2009).

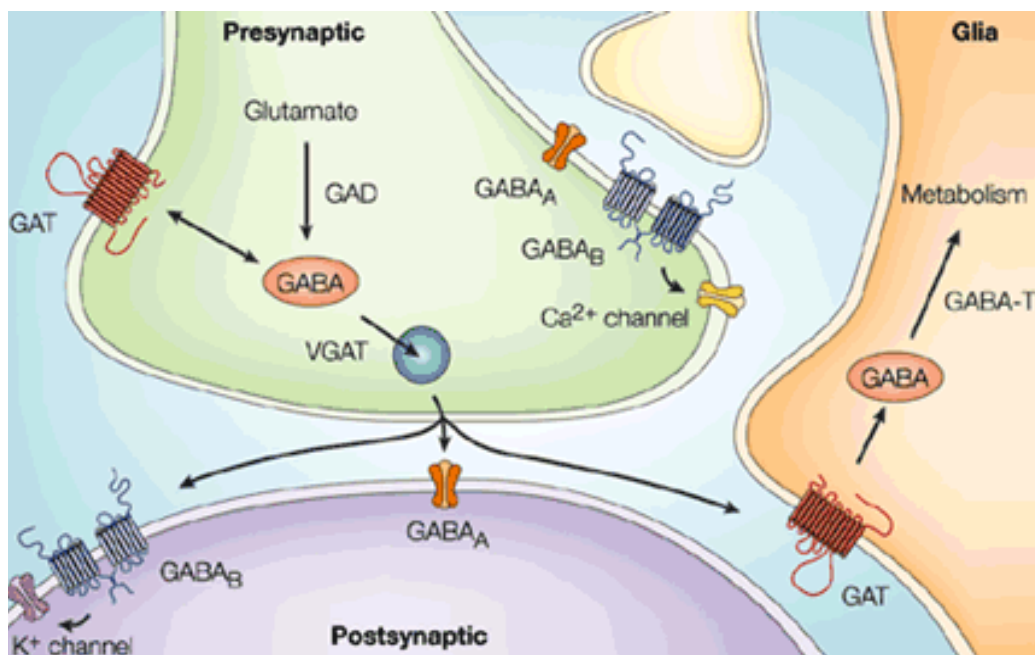

**Fig. 2.** Schematic illustration of GABA release, transport, synthesis and reuptake. GABA:  $\gamma$ -amino-butyrac acid, glu=glutamate, gln= glutamine, GAD= glutamic acid decarboxylase, GABA-T=GABA transaminase, GLNase=glutaminase, GABA-T=GABA transporter, GABA-A=GABAA receptor (Owens and Kriegstein, 2002).

GABA release by the synapse depends upon the loading of GABA into the synaptic vesicles, which is mediated by the vesicular inhibitory amino acid transporter (VIAAT) (Gasnier, 2004). After the release, the extracellular GABA is recycled into the presynaptic neurons. This is performed predominately by the GABA transporters (GAT): GAT1, GAT2 and GAT3 (Madsen et al., 2009). Astrocytes and other glial cells are involved in the reuptake of GABA, escaped from the synapse and this is predominately through the GABA transporter: GAT3 (Madsen et al., 2009). Soon after the GABA reuptake, it is disintegrated from GABA into glutamate by the GABA transaminase (GABA-T) (Coghlan et al., 2012) (Fig. 2).

GABA binds to the membrane receptors and thus mediates the downstream cascade of events. Function of GABA is mediated by two types of receptors: ionotropic and metabotropic. The GABA(A)-subtype constitutes the ionotropic receptors whereas GABA(B)- and GABA(C)-subtypes are the metabotropic receptors (Barnard et al., 1998; Sieghart and Sperk, 2002; Zheleznova et al., 2009).

GABA(A) receptors are mostly present at the post-synaptic end of the synaptic connections. These receptors are distributed in different brain regions according to their mRNA, protein or their respective receptor type expression (Oukari and Korpi, 2010; Olsen and Sieghart, 2008). GABA(A) receptor functions via the binding of the GABA to the receptor and resulting in the enhancement of the conductance. The ionopore, which results in anions conductance, especially the bicarbonate and the chloride ions (Roth and Draguhn, 2011), results in an increase of the negative charged ions within the cells, leading to the hyperpolarization of the membrane resting potential. This leads to the inhibition of the potentially firing cell. Structurally, GABA(A) receptors are heteropentamers arranged around a central pore (Fig. 3.).



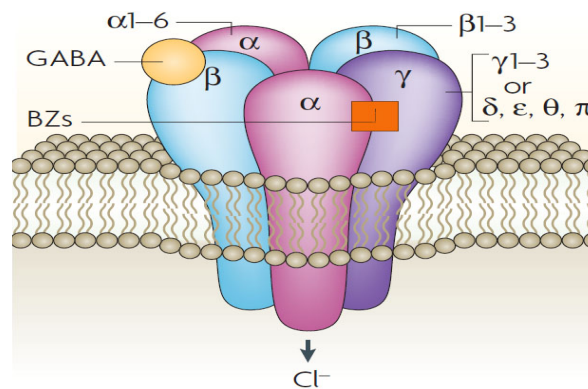

**Fig. 3.** Schematic representation of the pentameric GABA(A) receptor (Jacob et al., 2008).

The subunits are from 7 different families ( $\alpha$ 1-6,  $\beta$ 1-3,  $\gamma$  1-3,  $\delta$ ,  $\epsilon$ ,  $\theta$ , and  $\rho$ 1-3), typically combined following a 2 $\alpha$ : 2 $\beta$ :  $\gamma$  stoichiometry to form a GABA-activated chloride channel (Barnard et al., 1998; Herd et al., 2007; Luscher et al., 2011). The subunit compositions are quite critical both from the specificity and functional aspect (Oukari and Korpi, 2010). Animal models are being widely used to further dissect and understand the function of the GABA(A) receptor.

In addition animal models are also being widely used for understanding both the functional and specific nature of the GABA(A) receptor. One such example are transgenic mice with a point mutant at the  $\alpha$  subunit, studies with these mice underlined the specific nature of the subunit to the benzodiazepine (Rudolph and Mohler, 2004). Similar work has been done to address the specific role of different GABA(A) subunits (Homanics et al., 1997; Houser and Esclapez, 2003; Kralic et al., 2002; Rau et al., 2009).

On the other hand, the GABA(B) receptors are known to mediate the postsynaptic effects of GABA in the GABAergic neuron connections (Roth and Draguhn, 2011). They were first studied on the presynaptic terminals where they influence transmission release by regulation of the neuronal calcium conductance. Later they were found to be present even on the post-synaptic neurons, where their activation resulted in the hyperpolarization (Bowery et al., 2002). GABA(B) is a homodimers with similar subunits (Bowery et al., 2002; Coghlan et al., 2012), associated with the secondary messenger system via the

binding and inhibition of the G couple protein (guanine nucleotide-binding proteins) (Bettler et al., 2004).

Many studies have shown association of the GABAergic dysfunction with the onset of number of pathological conditions like schizophrenia, autism, depression, bipolar disorder, post-traumatic stress disorder and epilepsy (Beaumont and Maccaferri, 2011; Coghlan et al., 2012; Cryan and Slattery, 2010; Treiman, 2001; Vaiva et al., 2006; Wassef et al., 2003). Therefore various studies are aimed to understand the function and regulation of GABA in the brain.

### **1.3. GAD and GABA related functions: memory consolidation, circadian regulation and social interaction**

#### ***Memory:***

Several studies have culminated the functional role of GABA and its synthesizing GAD enzyme in memory consolidation (Collinson et al., 2002; Rudolph and Moehler, 2004; Sangha et al., 2009; Stork et al., 2003).

Pharmacological studies have shown impairment of memory formation with GABA(A) agonist like muscimol and diazepam (Castellano and McGaugh, 1989), whereas enhanced performances in memory tasks with GABA(A) antagonist like bicuculline and flumazenil (Herzog et al., 1996). Studies have shown that reduction of GABA(A) receptors is linked to reduced spatial memory in the water maze learning task (Collinson et al., 2002; Crestani et al., 2002). Additionally a partial inverse agonist acting on the GABA(A) receptor showed enhanced performance of rats in the water maze test (Chambers et al., 2004) and marked impairment caused by the ethanol uptake in human subjects (Nutt et al., 2007). GABA concentration in the sensorimotor cortex has been found to be associated with motor learning in human subjects (Floyer-Lea et al., 2006). Studies have shown that reduction in GABA especially in the prefrontal inhibitory neurons may result in cell activity delay and impaired working memory in schizophrenic patients (Akbarian et al., 1995; Kobroi and Dash, 2006; Volk et al., 2000).

GABA has been associated with the regulation of fear memory. Fear memory is important because of its association with anxiety disorders, posttraumatic stress disorder

and specific phobias (Day et al, 2004; Ehlers and Clark, 2000; Hackmann and Homes, 2004). Numerous works to dissect the neuronal network mediating fear learning involved the auditory Pavlovian fear condition paradigm. In this paradigm, an emotionally neutral auditory conditioned stimulus (CS), such as tone, is repeatedly paired with an aversive unconditioned stimulus (US), such as a shock. After a brief exposure to CS and US pairing, the CS initiate both learned behavioral and physiological responses that are characteristic of a fear state (Chhatwal and Ressler, 2007; Maren, 2008).

Administration of GABA(A) receptor agonist after a short re-exposure to the conditioned stimulus results in detrimental effects of GABA on memory consolidation. Whereas, a treatment with GABA(A) antagonist (Midazolam) results in the memory retention via post-reactivation (Makkar et al., 2010). Most of the work by Ressler et al., addressed the role of GABA in fear conditioning example: change in GABA(A) subunits, GAD67 and GAT1 mRNA in amygdala after paired tone shock exposure (Heldt and Ressler, 2007). Thus suggesting a decrease of benzodiazepine effects results in the reduction of the GABAergic inhibitory transmission and hence an increase in excitatory input in the amygdala.

Although memory especially fear memory consolidation and its mediation through GABA involves various regions in the brain. But the two most critical regions in the neural bases of fear conditioning are: Amygdala and Hippocampus.

***Amygdala:*** It is a critical site for the synaptic plasticity that occurs during the acquisition, retention and extinction of conditioned fear (Falls et al., 1992; Hobin et al., 2003; Maren, 2001; Santini et al., 2001; Szapiro et al., 2003; Walker and Davis, 2002). The acquisition and consolidation of fear memory appears to be crucially regulated by the amygdala. Lesion of amygdala results in inhibition of the memory –modulatory effect of muscimol and bicuculine during post training administration (Ammassari-Teule et al., 1991).

Lateral amygdala (LA), is known to be the key site for the fear conditioning (LeDoux, 2000; Maren and Quirk, 2004; Schafe et al., 2005). Electrophysiological studies have shown that both the CS (conditioned stimulus) and US (unconditioned stimulus) pathway converge onto a single cell in the LA. The LA cells showed enhanced response to CS on paired presentation with CS and US (LeDoux, 2000; Schafe et al., 2005). Pharmacological manipulation of LA at specific time with respect to training impairs

both short and long term memory of fear conditioning respectively (Rodrigues et al., 2004).

Basolateral amygdala (BLA), is another subregion of the amygdala to contain a powerful inhibitory circuit that functions through GABA modulation (Manzanares et al., 2005; Takagi and Yamamoto, 1981). Compared to other amygdala subregions the benzodiazepine- and GABA(A) receptor is higher in BLA (Niehoff and Kuhar, 1983). Thus suggesting reduction in fear consolidation and anxiety by the benzodiazepine or GABA(A) agonist administration in the BLA (Jasnow and Huhman, 2001; Manzanares et al., 2005; Scheel-Kruger and Petersen, 1982).

**Hippocampus:** It forms another neural basis involved in the fear acquisition especially in regards to context. Fear memory conditioned to contextual fear contains two processes: an initial association to the context and secondary formation of the link between the context and the shock delivered. Hippocampus is involved with the initial association to context whereas amygdala i.e., BLA is involved with the association of the context to the shock. Thus the hippocampus functions in the storage of fear memory. Infusion of the hippocampus after training with midazolam (GABA agonist) results in the disruption of contextual fear memory (Gafford et al., 2005). Studies with GABA(A) receptor subunit  $\alpha 5$  emphasized its role in the regulation of hippocampal dependent memory (Rudolph and Mohler, 2006). Transgenic mice with attenuated  $\alpha 5$  subunit of GABA(A) receptor failed to show any improvement in delayed fear conditioning which is an hippocampal independent task, whereas performed better in hippocampal dependent trace fear conditioning (Crestani et al., 2002; Makkar et al., 2012; Yee et al., 2004). Pirker et al., (2000) showed abundant expression of various GABA(A) receptor subunits in the hippocampus. Studies have shown administration of bicuculline in the CA1 (*Cornus*

*Ammonis*) hippocampus subregion resulted in an increase in memory consolidation at 1.5 h or immediately after training (Luft et al., 2004). It also has been demonstrated that injection of the GABAergic compounds post-training results in modulation of memory storage (Hatfield et al., 1999). Hence suggesting a functional role of GABA(A) subunit and the mediation of contextual fear memory through the hippocampus. Thus, emphasizing the ubiquitous role of GABA in learning and memory.

GAD isoforms have been associated with memory consolidation as well. Studies with GAD65 null mice showed reduced responses in Pre-pulse inhibition<sup>2</sup> (PPI) (Heldt et al., 2004). GAD65 gene has been found to be associated with cued fear conditioning both in the hippocampus and amygdala (Bergado-Acosta et al., 2008) On the other hand reduction in GAD67 expression has been associated with the impairment of both learning and memory. Pharmacological studies have shown restoration of the GAD67 in the deficient transgenic mice result both improvement in response to Y-maze spatial memory and PPI (Kutiyanawalla et al., 2012). *In vivo* studies with bilateral injection of GAD67 siRNA resulted in deficits in extinction but no effects either in acquisition or retention of fear (Heldt et al., 2012). Thus, supporting the functional role of GAD and GABA in processing of learning and memory.

***Circadian and REM regulation:***

GABA has been associated even with the regulation of the circadian rhythm in suprachiasmatic nucleus and other associated regions of the brain (Kaila, 1994; Mody et al., 1994). Evidence suggests that GABA acts as an excitatory neurotransmitter during the day and they assume the inhibitory function during the night. Thus indicating that GABA may trigger the amplitude of firing activity during the circadian rhythm (Bos and Mirmiran, 1993; De Jeu and Pennartz, 2002; Gribkoff et al., 1999; Liou et al., 1990; Liou and Albers, 1990; Liu and Reppert, 2000). Benzodiazepines, have shown to mediate changes in sleep architecture by targeting the GABA(A) receptor (Tobler et al., 2001). GAD65 transgenic mice showed altered circadian activation and its interference with conditioned fear memory response (Bergado-Acosta et al., 2014).

***Social behavior:***

Both the phasic and the tonic GABA(A) mediated inhibition may contribute to abnormal social behavior. One such example is the impaired social behavior in the FMR1 (fragile X mental retardation 1) null mice mediated by a deficit in GABA levels in the basolateral nuclei of the amygdala (Olmos-Serran et al., 2010). Studies have shown targeted deletion

---

<sup>2</sup> A neurological mechanism in which a weak pre-stimuli (prepulse) inhibits the reaction to a subsequent strong startling stimuli (pulse).

of the GABA(A) receptor gene encoding the  $\beta 3$  subunit results in abnormal social and cognitive behavior (DeLorey et al., 2008; Homanics et al., 1997; Pizzarelli and Cherubini, 2011). Additionally, disruption of the GABAergic interneuron development during the early postnatal period results in social deficits (Levitt, 2005). Human studies have shown stimulation of GABAergic signaling with benzodiazepines modulates social interaction in a dosage dependent manner (Lane and Gowin, 2009). Hypermethylation of the GAD67 promoter showed social deficit and administration of Imidazenil (selective positive allosteric modulator of GABA at GABA(A) receptors), corrects the social deficit (Tremolizzo et al., 2005).

#### **1.4. Deficits in GABA / GAD levels in psychiatric disorders**

Disturbance in the GABA and GAD levels have been associated with number of psychiatric disorders like bipolar disorder, autism, depression, mood disorders and schizophrenia (Beaumont and Maccaferri, 2011; Coghlan et al., 2012; Cryan and Slattery, 2010; Fatemi et al., 2002; Gonzalez-Burgos et al., 2011; Guidotti et al., 2000; Hashimoto et al., 2003; Heckers et al., 2002; Treiman, 2001; Vaiva et al., 2006; Wassef et al., 2003).

Bipolar disorder is one such psychiatric disorders associated with GABAergic dysfunction (Fatemi et al., 2013; Korpi and Sinkkonen, 2006). Reduction in the GABA levels both in the plasma and cerebro-spinal fluid has been reported in bipolar subjects (Petty et al., 1990; 1995). Pharmacological studies have shown that administration of antipsychotics resulted in the normalization of the elevated GABA levels in bipolar patients. Likewise, low levels of GABA were found in the occipital cortex of patients

with panic disorder and major depression compared to healthy subjects with magnetic resonance spectroscopy (Brambilla et al., 2003; Goddard et al., 2001).

Earlier studies have demonstrated a reduction in the GABA receptor mRNA and protein expression in hippocampal interneurons in schizophrenia and bipolar disorder (Benes et al., 2007; Heckers et al., 2002). Another supporting finding is the reduction in GAD67 mRNA in *post mortem* brains of schizophrenic subjects (Guidotti et al., 2000). Studies have established significant reduction in the GAD67 expression in several brain regions in schizophrenic and bipolar conditions (Guidotti et al., 2000; Heckers et al., 2002; Impagnatiello et al., 1998). This was shown with *post mortem* brain analysis showed 30-50 % reduction in the GAD67 protein and mRNA expression both in the prefrontal cortex and cerebellar region in schizophrenia patients (Guidotti et al., 2000). Compared to the GAD67, GAD65 has been less frequent as a candidate to investigate its association with schizophrenia and bipolar disorder.

Another disorder closely linked to schizophrenia with impaired social behavior and associated with GABA dysfunction is autism. Autism is a pervasive developmental disorder in which both social and language development are adversely affected. The individual suffering with the disorder shows abnormal responses to both different sensory stimuli and to sensory gating (Rapin, 1991; Rapin and Katzman, 1998; Yip et al., 2007). GABA has also been established to be associated with autism (Palmen et al., 2004). GAD67 protein is known to be decrease by 51 % in the cerebellum and by 61 % in the parietal cortex in the autistic patients. On the other hand, GAD65 protein is reduced by 50 % in the cerebellum and 48 % in the parietal cortex in autistic subjects (Blatt et al., 2001; Fatemi et al., 2002). Autism related studies support the role of GAD and GABA receptor gene in its mediation. Thus suggesting both GABA and GAD are critical for the onset of the disorder. Therefore, a better understanding of the either will be valuable for our understanding and treatment of various psychiatric disorders.

### 1.5. Estrogens as a modulator of GABA / GAD

Estrogens, are an ovarian steroid hormone associated with regulation of various social and sexual behaviors in animals and humans. They are involved with various functions like regulation of growth, differentiation, development and maturation.

Extensive research both in animals and humans with estrogen has established it as one of the modulator effecting both the structure and function of the nervous system.

Estrogens have been described to be neuroprotective in nature (Connell and Saleh, 2011). Administration of 17 $\beta$ -estradiol leads to restoration of the young brain with apoptotic neurodegeneration (Asimiadou et al., 2005; Pytel et al., 2006). *In vitro* studies with neuron cultures have shown estrogens to interfere with the insults and thus protecting the neuron from various insults like oxidative stress, amyloid- $\beta$  toxicity and glutamate excitotoxicity<sup>3</sup> (Behl et al., 2002; Bishop and Simpkins, 1994; Green et al., 2000). Estrogens are known to be associated with brain trauma and neurodegeneration (Behl, 2002). Estrogens are found to rescue the detrimental consequences of ischemic stroke in rats when applied 3 h prior to the injury (Yang et al., 2000), which suggests they are protective in nature. Often stroke patients are recommended estrogens for dietary supplements for a rapid recovery of the affected region (McCullough et al., 2001). Additionally, estradiol<sup>4</sup> also has been found to ameliorate neurotoxicity induced by up-regulation of the GABA(A) receptors (Pytel et al, 2007). Although there is a close link between the estrogens and GABA modulation, however it is suggested to be an indirect link than a direct regulation. At the molecular level the 17 $\beta$ -estradiol mediated neuroprotection is correlated with increase in the phosphorylated ERK1/2 (extracellular signal regulated kinase) and AKT (v-akt murine thymoma viral oncogene homolog) (Pytel et al., 2007). Therefore suggesting that 17 $\beta$ -estradiol may be associated with the activation of proteins related to cell survival and other protection protein. Many evidence support estrogens to modulate GABA, it is plausible long-term treatment with 17 $\beta$ -estradiol could influence the structure of neuronal cells and modulate the GABAergic transmission through an indirect mechanism. Primary hippocampal culture treated with

---

<sup>3</sup> A pathological process which cause damage of neurons with excessive stimulation by excitatory neurotransmitters.

<sup>4</sup> It is the natural occurring sex hormone synthesized from ovaries in females and testosterone in male.



estradiol resulted in down regulation of brain derived neurotrophic factor, hence result in attenuation of inhibition and of GAD expression (Murphy et al., 1998).  $17\beta$ -estradiol attenuates the number of GAD positive stained cells in adult brain (Rudick and Woolley, 2001, 2003; Rudick et al., 2003; Pytel et al., 2007).

During *in vitro* study with NT2-N cells, when treated with  $17\beta$ -estradiol for 2 days, attenuation of GAD was observed. However, the effect was diluted with 7 days of treatment (Pierson et al., 2005). Similar studies have shown that treatment with both progesterone and  $17\beta$ -estradiol induced an increase of tonic currents in the neurons of CA1 hippocampal subregion (Shen et al., 2005; Wu et al., 2013). Both  $17\beta$ -estradiol and progesterone have shown to modulate the GABA(A) receptor subunit expression in the brain (Noriega et al., 2010).

Estrogens receptors (ER) are of two types: ER $\alpha$  and ER $\beta$ . Both the receptors are synthesized from two different genes located on different chromosome (Mario et al., 2006). The two receptors are similar at structural and functional level (Behl, 2002). They are known to be present in the astrocytes, different glial cells and in the peripheral nervous system, with an overlap of ER $\alpha$  and ER $\beta$  in most of the brain regions (Azcoitia et al., 2001; Gudino-Cabrera and Nieto-Samperdro, 1999; Santagati et al., 1994). These receptors are highly expressed in forebrain, medial preoptic area, amygdala and hypothalamus (Fig. 4).

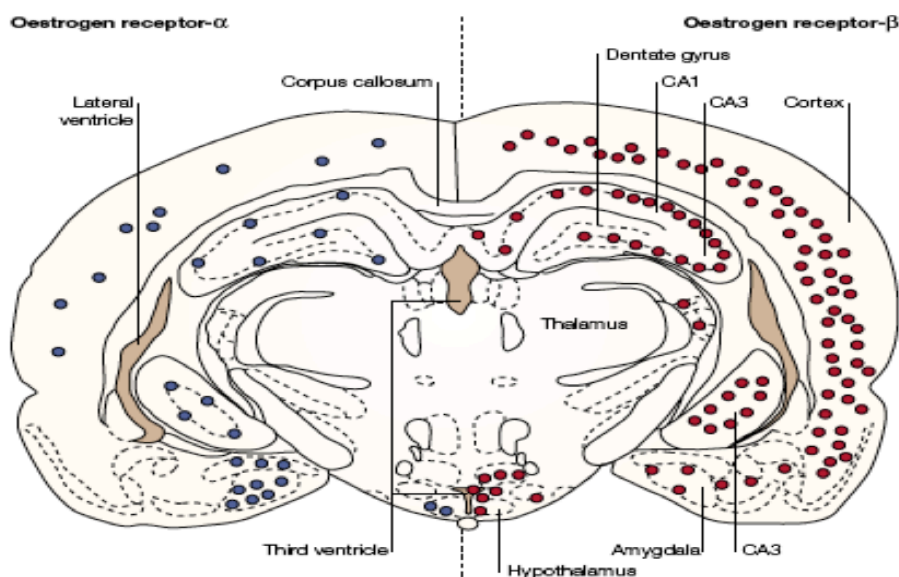

**Fig. 4.** Diagrammatic representation of the distribution of the two types of estrogens receptors in the rodent brain (Behl, 2002).

Estrogens functions at the molecular level by active binding of the 17 $\beta$ -estradiol ligand to the receptor which results in a sequential events such as receptor dimerization, gene-transcription initiation, interaction with co-activators/transcription factors and interaction (Behl, 2002). Estrogens interaction results in the formation of protein DNA complex (Klinge, 2001; Nilsson et al., 2001). Both the ER receptor protein form homo or heterodimers and bind to the DNA on the ERE (Estrogens response elements<sup>5</sup>) sequence, which is normally located at the promoter regions of estrogen responsive genes. Estrogens have been associated with the transcription of various transcription factors such as peptide hormones, neurotransmitter metabolism associated protein, growth factors (BDNF: brain derived neurotrophic factor) and anti-apoptotic proteins (Nilsson et al., 2001; Behl, 2002). Being such a central player in many of the critical systems, therefore several studies related to estrogen has always been of keen interest.

There are many sources of estrogens. Phytoestrogens have turned out to be one of the prominent plant derived sources of estrogens. Extensive work is being done to understand estrogens and its associated function with the use of phytoestrogens as a means. Phytoestrogens are being seen as an alternative to the HRT (hormone replacement therapy) and ERT (estrogens replacement therapy) due to its plant origin and limited toxicity (Ososki and Kennelly, 2003).

### **1.6. Phytoestrogens role players for estrogens**

Phytoestrogens are plant-derived compounds that mimic estrogens both structurally and functionally. Hence, they have been widely used for the prevention of cancer, osteoporosis, menopausal symptoms and heart disease (Kronenberg and Fugh-Berman, 2002; Stechell, 1998). Phytoestrogens are classified into several types: Steroidal estrogens and phenolic estrogens, isoflavones, coumestans and lignans. The other classes like: anthraquinones (Matsuda et al., 2001), chalcones (Rafi et al., 2000), flavones (Miligan et al., 1999) saponins (Chan et al., 2002) and prenylflavonoids (Kitaoka et al., 1998; Ososki and Kennelly, 2003) (Table 1.).

---

<sup>5</sup> They are short sequence within the promoter of the gene where estrogen binds and regulate transcription.

**Table 1.** Classification of dietary source and structure of the most common phytoestrogens. The structure of the  $17\beta$ -estradiol has been added as a reference (Patisaul and Jefferson, 2010).

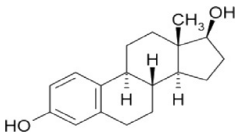
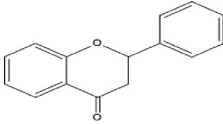
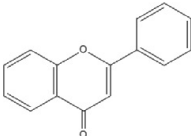
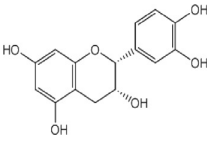
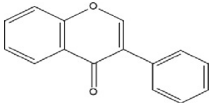
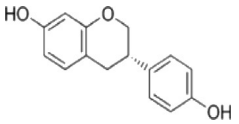
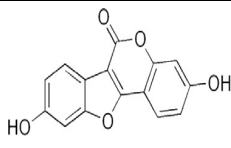
| Group                | Sub-group           | Example                                    | Dietary sources             | Basic structure   |
|----------------------|---------------------|--|-----------------------------|---|
| $17\beta$ -Estradiol | Endogenous estrogen | NA   |                             |     |
| Flavonoids           | Flavanones          | Eriodictyol, Hesperentin, Naringenin       | Citrus fruits and juices.   |    |
|                      | Flavones            | Apigenin, Luteolin, Tangeritin             | Parsley, celery, peppers.   |  |
|                      | Catechins           | Proanthocyanidins                          | Chocolate green tea, beans. |  |
| Isoflavonoid         | Isoflavones         | BiochaninA, Glycitein, Diadzein, Genistein | Soy beans, legumes.         |  |
|                      | Isoflavans          | Equol                                      | Equol metabolite.           |   |
|                      | Coumestan           | Coumestrol                                 | Clover, Alfalfa.            |   |

Isoflavones are the most widely known of the phytoestrogens. They are naturally found biologically inactive glycoside conjugates with glucose or carbohydrate moieties. Daidzein and genistein are the most common isoflavones known. Other isoflavones are biochanin A and formononetin

Genistein is one of the biologically active flavonoids and occur in high concentration in soy. Blood concentration of different genistein metabolites was found to be 100 to 1000 times higher in high-soy consumers (Patosaul and Jefferson, 2010). Genistein has been acknowledged as an inhibitor for both cancer cell growth and metastasis and with its role to ameliorate various types of cancer. Due to the different associated benefits, efforts are being made to increase the concentration of genistein and other isoflavones in the diet. Foods are being fortified with genistein and different isoflavones in order to increase its supply, but soy products are the most important source for dietary genistein especially in humans (Pavese et al., 2010). Individual consuming daily soy-based diet contains 0.3 to 1.0 mg genistein per kilogram body weight per day (Pavese et al., 2010). Additionally, pharmacological studies in animals have shown that after injection, hydrolysis and absorption in intestine, genistein undergoes initial metabolism in the liver and also in enterohepatic circulation (Sfakianos et al., 1997). It has been known that on digestion, both daidzein and genistein are metabolized into equol and 5-hydroxy-equol. Studies have shown *Slackia isoflavoniconvertens*, a gut bacteria which has been shown to present in the intestine of humans mediates this metabolism (Matties et al., 2012). Unlike genistein and daidzein, equol is not of plant origin but metabolized in animal and human gut. Dietary studies have shown 25-30 % of the western population and 50-60 % of eastern population (countries like Japan and China) to produce equol after consuming diets rich in isoflavones (Atkinson et al., 2005; Setchell and Cole, 2006). Equol showed a reduced binding affinity of 2 % to the estrogen ER $\alpha$  whereas a higher affinity to ER $\beta$  (Lund et al., 2004). It is also known to show binding affinity to dihydrotestosterone (DHT), an androgen and known to be highly expressed in the prostate, testes, hair follicle and adrenal glands (Hemat, 2004).

Dietary studies in human showed that approximately 90 % of genistein in the blood undergoes metabolism in liver (glucuronidated or sulfate form) and the residual 10 % exist in free non-conjugated form (Aldercreutz et al., 1995). The biological activity of free genistein is limited and different compared to its conjugated metabolic products

(Pavese et al., 2010; Pugazhendhi et al., 2008). Thus suggesting, free genistein in the blood of soy consumers is in the lower nanomolar range. However studies have shown that effects induced by genistein *in vitro* involve high concentration, whereas they are functional at low concentration *in vivo*. Most of the studies addressing the function of phytoestrogens involve dietary soy uptake because they provide a measure of steady state of genistein in blood concentration of human. Studies have shown that genistein is associated with inhibitory pathways linked to cell growth and proliferation, thus affecting multiple organ system. It is highly expressed in different brain regions, including the hippocampus, and is critical for various brain functions like synaptic plasticity, neurodegeneration and during neuronal injury (Gao et al., 2004; Liu et al., 2005).

One of the most characterized functions of phytoestrogens are via estrogens receptor binding. Most of the phytoestrogens including the isoflavones bind both to the ER $\alpha$  and ER $\beta$ , thus triggering the downstream ER-dependent gene transcription. Studies with genistein have shown 7-48 fold more selectivity for ER $\beta$  then ER $\alpha$ , varying on the assay used for detection (Barkhem et al., 1998). Most of the studies with phytoestrogens showed that it binds more efficiently to ER $\beta$  then to ER $\alpha$ , because they are differentially distributed in the body and brain. Phytoestrogens bind to ERs and initiate transcription through interactions with EREs (Estrogens response elements) or by binding immediate early genes<sup>6</sup>, such as Jun and Fos (Kushner et al., 2000). Estrogens have also been associated with initiation of rapid non-genomic cascade through binding to specialized steroid membrane receptors at the cell surface (Falkenstein et al., 2000; Levin, 2009; Patisaul and Jefferson, 2010). Binding of ligand to the membrane receptors cause rapid activation of downstream second messenger pathways like cAMP (Cyclic adenosine monophosphate) or increased intracellular levels of calcium. Thus resulting in the activation of signal transduction pathways of differentiation, neuronal signaling and other cellular processes. Phytoestrogens are found to manipulate the genome by modulation of enzymes required for steroid biosynthesis. They are also known to regulate steroid biosynthesis and transport by stimulating hormone-binding globulin (SHBG) produced in liver cell (Adlercreutz et al., 1992).

---

<sup>6</sup> These genes are rapidly activated at transcriptional levels with the first response of cellular stimuli.

Male Syrian hamsters kept on soy-rich diet for 5 weeks showed increased aggression and circulating testosterone levels compared to control animals fed on soy free diet (Moore et al., 2004). Additionally an anxiolytic effect of phytoestrogen has been observed in gonadal intact male and female rats exposed over their entire lifetimes but not when administered briefly in adulthood with phytoestrogen (Lephart et al., 2005). Thus phytoestrogens have shown to display a wide range of effects in adult brain (Patisaul and Jefferson, 2010).

Another pathway, through which phytoestrogens mediate their function is via their interaction with neurosteroids i.e., aromatase. Studies have shown phytoestrogen to interact with aromatase both in human and rodents (Le Bail et al., 2000). Additionally, phytoestrogen (genistein and equol) also interact with the regulation and synthesis of pregnenolone, which is critical for the synthesis of the neurosteroid and its related function (Hu et al., 2010; Pinna et al., 2008).

## **2. Hypothesis:**

Studies have shown that GAD isoforms are associated in regulation of various behavior functions like anxiety, circadian rhythm, homeostasis and memory consolidation (Bergado-Acosta et al., 2008, 2014; Campo et al., 2009; Hettema et al., 2006).

GAD67 has been associated with a number of psychiatric conditions whereas limited information is known about its relation with various symptoms. Social impairment is one such symptom associated with a number of psychiatric conditions. During the first part of my study, I aimed towards understanding the role of GAD67 in the modulation of the social behavior. To address this, I used only heterozygous GAD67-GFP (green fluorescence protein) knock-in male mice because complete knockout mice die postnatal due to the cleft formation (Tamamaki et al., 2003). GAD67<sup>+/-</sup> mice show an overall 40 % reduction of GAD67 expression and a 16 % reduction of GABA levels in the adult brain (Wang et al., 2009). In my study design, I aim to assess the behavioral response of the GAD67<sup>+/-</sup> male mice to social stimuli. Social interaction is often related with olfactory function and aggression. Later I assessed the behavior output of the GAD67<sup>+/-</sup> mice towards different set of olfactory stimuli (social or non social) and also response towards the intruder in territorial aggression test. My aim was to measure the role of GAD67 in the regulation of the innate behaviors like nest building, urine marking test and anxiety measures.

Estrogens are known to alter GABA conduction (Majewska, 1992), with an increase in GABA(A) antagonist binding affinity (Juptner et al., 1991; Jussofie et al., 1995), increase GABA(A) subunit ( $\alpha_2$  and  $\gamma_1$ ) mRNA (Herbison and Fenelon, 1995) and to alter GAD mRNA levels (Davis et al., 1996; McCarthy et al., 1995). Thus, is it plausible that estrogens do regulate GAD expression. Therefore, in the second and third chapter I investigated the role of phytoestrogen on GAD function.

Phytoestrogens are plant by-products that mimic the estrogens analogs. They constituents major source of protein for the laboratory rodent diet. Phytoestrogens are found to influence neurosteroids or circulating estrogens levels in the blood (Le Bail et al., 2000; Weber et al., 2001). They are known to exert direct effects on the brain estrogen receptors (Kostelac et al., 2003; Mueller et al., 2004). Neurosteroids are endogenous steroid hormones associated with the modulation of the GABA(A) receptor by a direct action on the cell (Pinna et al., 2008). Human studies have shown interaction of phytoestrogens

with the regulation of neurosteroids (Le Bail et al., 2000). Estrogens are known to influence both the transcription and translation of the GAD (Brinton et al., 2001; Nakamura et al., 2005) and also modulate the GABA(A) receptors by altering gene transcription. Thus suggesting phytoestrogens to be one of the modulators to influence GABA and GAD function (Fig. 5.).

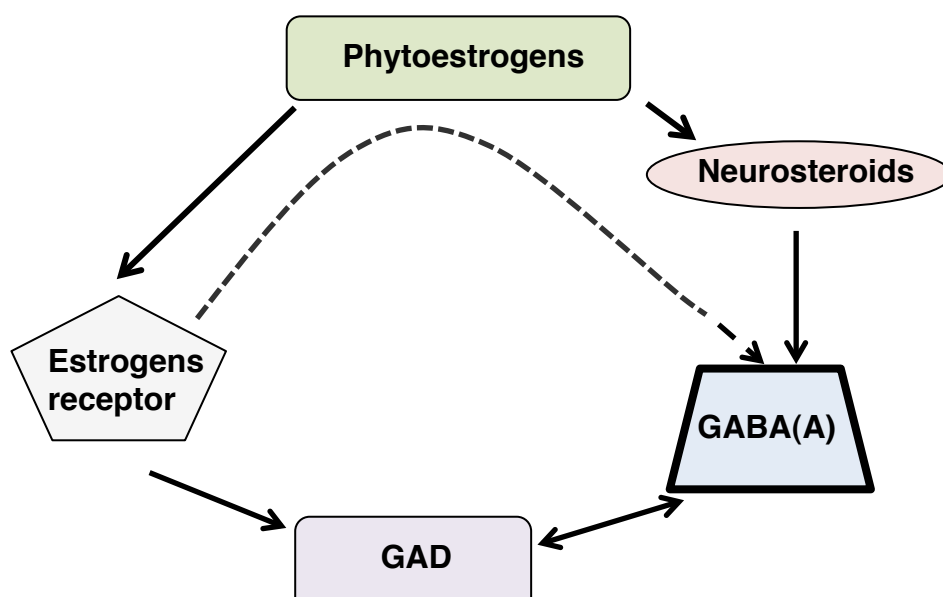

**Fig. 5.** Diagrammatic representation of phytoestrogens interaction with GABA(A) receptors and GAD expression via estrogen receptors and through neurosteroid metabolite. The dotted line show the indirect interactions and straight line represent the direct interactions.

In chapter two I answered the following question:

Do phytoestrogens effects social behavior? Do they mimic GAD67 deficit state?

I use the non-invasive diet administration approach because this helps to maintain a constant blood plasma level of phytoestrogens metabolite (daidzein and genistein). C57Bl/6 male mice were treated with two dietary conditions; one with phytoestrogen called phyto150 containing 150 mg of genistein and daidzein each, and the other phytoestrogens absent condition called phyto0 for a duration of 6 weeks. The treated



animals were exposed to different social and olfactory stimuli similar to the one carried out in GAD67 social behavior assessment. Studies have shown a close link between estrogens and aggression. To validate this I measured territorial aggression in the resident intruder aggression paradigm. For the purpose to investigate effects of phytoestrogens on phenotype I measured various innate behaviors like nest building and urine marking patterns.

Once I validated that phytoestrogens do modulate social behavior and mimic GAD67 similar social behavior. I addressed the following question:

Do phytoestrogen mediate change in GAD (65 and 67) at phenotypic and molecular level?

For the purpose of GAD67 activity measure I used GAD67-GFP mice and treated them with the two different diets. I quantified the GFP inserted in GAD67 gene as a measure to validate GAD67 activity. Further I quantified the gene expression with real time PCR in C57Bl/6 mice treated with the two diets for GAD67 and 65 gene. I furthermore measured the anxiolytic effects of phytoestrogens both in anxiety parameter and fear memory paradigm.

### 3. Methods:

#### 3.1. Animal experiment

##### 3.1.1. Animal housing

The mice used during my study were housed under standard laboratory conditions. The mice were housed together in groups of two to five animals in Macrolon cages (36.2x16x14.3 cm) with standard bedding. Room temperature and moisture was regulated by an automated air conditioning system with 22 °C air temperature and 70 % moisture content. Animals were raised in a 12:12 reverse light/dark cycle (lights off at 7:00 with a 30 min dawn phase) with food and water ad libitum.

Animals were separated one week prior to the test into single cages. All experiments were conducted during the active phase i.e., from 10:00-16:00. 15-17 week old mice were used during the test, whereas 6-8 week old male mice were used as an intruder in aggression test paradigm.

##### 3.1.2. Animal diet

Animals were kept on the commercially standard diet: Ssniff R/M-H V-1534 from Ssniff Spezialdiäten, Soest, Germany. The diet contains the following components:

**Table 2.1.** The different components of Ssniff R/M-H V-1534 diet were:

|             |       |
|-------------|-------|
| Soy protein | 19%   |
| Crude fat   | 3.30% |
| Crude fiber | 4.9%  |
| Crude ash   | 6.4%  |
| Calcium     | 1%    |

The soy in the diet contained 150 mg/kg of genistein and daidzein each and both are phytoestrogens in nature. The soy forms a major source of protein for the laboratory rodents and hence critical for the overall development of the animals. Therefore for the purpose of the health and muscle growth, the mice were fed with diet containing phytoestrogen till the animals were twelve week old. Once mice became mature the diet was changed in the test batch from phytoestrogen to phytoestrogen free or soy free diet Ssniff R/M-H V-1554. Animals fed with soy free or phytoestrogen free diet, were addressed as phyto0 and the control mice fed with standard soy diet were addressed as phyto150. The mice were fed in group-housing for a period of 6 weeks and after 6 weeks they were single caged and used for the experimentation.

During the standardization I observed no change in weight or difference in consumption and preference amount by the animals for either of the two diets.

### **3.1.3. Animal welfare**

Animal housing and experiments were conducted in accordance with the European and German regulations for animal experiments approved by the Landesverwaltungsamt Saxony-Anhalt (animal permission Nr. 42502-2-887 UniMD).

### **3.1.4. Animal strains**

#### *3.1.4.1. GAD67-GFP mice strain:*

GAD67 mutant mice and their wildtype littermates descended from a mutant line with a targeted insertion of the GFP (green fluorescence protein). The transgenic mice were generated by the insertion of the GFP gene in the exon one near the starting codon of GAD67 gene (Tamamaki et al., 2003). This mutant line was backcrossed to C57Bl/6 genetic background for more than fifteen generations. The complete mutant mice die postnatal due to cleft palate formation. Therefore for experiments only the GAD67 heterozygous mice were used. For breeding, male GAD67<sup>+/+</sup> mice were bred with female

GAD67<sup>+/-</sup> mice. Animals were weaned after four weeks, the litters were raised in groups of two to five animals.

#### *3.1.4.2. GAD65 mice strain:*

The GAD65 mutant line carried a targeted disruption of the GAD65 gene by inserting a neomycin cassette that replaces most of the third exon of the GAD65 gene (Asada et al., 1996). The mutant line was backcrossed to C57Bl/6 genetic background for more than fifteen generations. For experimental purposes, male GAD65<sup>+/-</sup> mice were bred with GAD65<sup>+/-</sup> female obtaining GAD65<sup>+/-</sup> and GAD65<sup>-/-</sup> litters from the breeding pair. The animals were weaned for four weeks and then raised in groups of two to five animals.

### **3.1.5. GAD67 and 65 genotyping**

#### *3.1.5.1. DNA extraction for genotyping:*

Approximately 0.5 cm of mouse-tail was collected in an eppendorf tube. 200 µL of PCR-direct lysis buffer was added to the tail tissue. To lysate the proteins in the tail tissue, 6 µL of proteinase K (10 mg/mL) was added. The contents were incubated overnight for lysis at 55 °C. On the adjacent day the lysates were heat inactivated by treating the samples for 45 min at 85 °C. The DNA probe present in the supernatant was collected and stored at -20 °C.

#### *3.1.5.2. Polymerase chain reaction for genotyping:*

The lysate was used to determine the genotype of the mice. Genotypes were determined by multiplex polymerase chain reaction on the genomic DNA. The polymerase chain reaction is a widely used method to amplify the DNA fragments of a known sequence *in vitro*. The techniques have an initial denaturation step during which the DNA strand denatures into two strands. This is followed by an annealing step, which is dependent on the T<sub>m</sub> value of the primers. During annealing step the primers bind to the DNA strand. After annealing is the extension during which dNTPs are inserted and

complementary strand is synthesized with the help of enzyme Taq polymerase

### 3.1.5.2.1. GAD67 DNA Polymerase chain reaction (PCR):

For genotyping of GAD67 mutants I used three different primers in a multiplex PCR. The GFP primer is a 3' primer specific for the GFP protein whereas the GAD67 wt (wild type) primer was complementary to a 3' sequence in the exon 1. The 5' primer GAD67 binds to region upstream of the starting codon.

**Table 2.2.** Primer Sequences (5' to 3') for genotyping of GAD67 mutant mice:

| Primer name | Sequence                               |
|-------------|--|
| GAD67 all   | <i>GGC ACA GCTCTC CCT TCT GTT TGC</i>  |
| GAD67 wt    | <i>GCT CTC CTT CTT TCG CGT TCC GAC</i> |
| GAD67 GFP   | <i>CTG CTT GTC GGC CAT GAT ATA GAC</i> |

**Table 2.3.** PCR Master mix for GAD67 genotyping: For 1X total volume 10  $\mu$ L:

| Reagents                                    | Volume ( $\mu$ L) |
|---|-------------------|
| 10x Taq buffer<br>(with MgCl <sub>2</sub> ) | 1.0               |
| Q-solution                                  | 2.0               |
| MgCl <sub>2</sub> (25mM)                    | 0.04              |
| dNTPs (2.5mM)                               | 0.4               |
| GAD67 all (10 $\mu$ M)                      | 0.6               |
| GAD67 wt (10 $\mu$ M)                       | 0.6               |
| GAD67 GFP (10 $\mu$ M)                      | 0.6               |
| DD Water                                    | 2.0               |
| Taq Polymerase (250 U)                      | 0.1               |

To the 9  $\mu\text{L}$  of master mix 1  $\mu\text{L}$  of the DNA probe was added. Next to the genomic DNA to determine the genotype of the mice, a negative control with water as well a positive control with template DNA from GAD67<sup>+/-</sup> mouse was included. This was followed by PCR cycle reaction.

**Table 2.4.** Thermo Cycler Program for GAD67 genotyping:

| Stages                          | Temperature | Time     |
|---------------------------------|-------------|----------|
| Initial denaturation            | 95 °C       | 5 min    |
| Cycle reaction<br>(x 35 cycles) | 94 °C       | 15 s     |
|                                 | 62 °C       | 35 s     |
|                                 | 72 °C       | 3 min    |
| Extension                       | 72 °C       | 7 min    |
| Cooling and storage             | 4 °C        | Infinite |

### 3.1.5.2.2. GAD65 DNA Polymerase chain reaction (PCR):

Genotyping of the GAD65 mutants was done with three different primers in a multiplex PCR. The GAD65 ko (knockout) primer was 3' primer specific for the neomycin cassette whereas GAD65 wt primer was complementary to a 3' sequence in exon three which is substituted with neomycin resistant gene in the GAD65 mutant mice. The 5' primer binds at exon 2 of the GAD65 gene.

**Table 2.5.** Primer Sequences (5' to 3') for genotyping of GAD65 mutant mice:.

| Primer name | Sequence                     |
|-------------|------------------------------|
| GAD65 all   | <i>GGAAGCCAGCGGAGGGCGG</i>   |
| GAD65 wt    | <i>GGCTGCTAAAGCCGATGCTC</i>  |
| GAD65 ko    | <i>CCATTACCTGTTGCGTGCA C</i> |

**Table 2.6.** PCR Master mix for GAD65 genotyping: For 1X total volume 10  $\mu$ L:

| Reagents                                    | Volume ( $\mu$ L) |
|---|-------------------|
| 10x Taq buffer<br>(with MgCl <sub>2</sub> ) | 1.0               |
| Q-solution                                  | 2.0               |
| dNTPs (2.5mM)                               | 1.0               |
| GAD65 all (10 $\mu$ M)                      | 0.3               |
| GAD65 wt (10 $\mu$ M)                       | 0.7               |
| GAD65 ko (10 $\mu$ M)                       | 1.0               |
| DD Water                                    | 2.9               |
| Taq Polymerase (250 U)                      | 0.1               |

To the 9  $\mu$ L of master mix 1  $\mu$ L of the DNA probe was added. Next to the genomic DNA to determine the genotype of the mice, a negative control with water as well a positive control with template DNA from GAD65<sup>+/-</sup> mouse was included. This was followed by PCR cycle reaction.

**Table 2.7.** Thermo Cycler Program for GAD65 genotyping:

| Stages                       | Temperature | Time     |
|------------------------------|-------------|----------|
| Initial denaturation         | 95 °C       | 5 min    |
| Initial denaturation         | 94 °C       | 20 s     |
| Cycle reaction (x 35 cycles) | 68 °C       | 90 s     |
| Extension                    | 72 °C       | 7 min    |
| Cooling and storage          | 4 °C        | Infinite |

### 3.1.5.3. Gel electrophoresis:

To analyze DNA fragments derived from the PCR amplification with gel electrophoresis. The agarose was mixed in TAE (Tris Acetic acid EDTA) buffer and heated in a microwave (600 Watt for 3 min) to insure the agarose gel powder was properly dissolved.

**Table 2.8.** 1% agarose gel preparation:

| Reagents | Volume |
|----------|--------|
| Agarose  | 1 g    |
| TAE (1X) | 100 mL |

The mixture was cooled at room temperature and 10  $\mu$ L of ethidium bromide (0.5 mg/mL) was added to the agarose gel. The agarose gel was poured into the gel caster and gel-comb was inserted. After cooling the comb were carefully removed and the gel was transferred to the electrophoresis chamber containing TAE buffer. Each PCR product was mixed with loading buffer (10  $\mu$ L DNA + 2  $\mu$ L 6x loading buffer) and transferred to an individual well. DNA strand marker was added at one end of the well, to quantify the size of the amplified DNA strand. Electrophoresis was performed at 100 mV for approximately 30 min. Detection and documentation of the DNA fragment was conducted with the InGenius LHR gel documentation and analysis system (Syngene, Cambridge, UK). The ultraviolet light when exposure to the DNA strands intercalated with ethidium bromide elicited fluorescence signal which was used for the visualization of the DNA and quantification of the size. Thereby, applying the three primers in a multiplex PCR for GAD67 genotyping resulted in a 100 bp fragment for the wildtype allele and 200 bp for the GFP containing allele.

For GAD65 genotyping the multiplex PCR showed 250 bp for the transgenic construct and a 100 bp for the wild allele.



## 3.2. Animal behavior

### 3.2.1. Anxiety assay:

#### 3.2.1.1. Open field test:

Open field test is apt both for qualitative and quantitative measure of activity and anxiety in test rodents. In normal conditions, mice avoid visits to the center field of the arena as they resemble threat and are high risk from a possible predator, thus inducing anxiety in the animal. Mice treated with anxiolytics show reduced anxiety values compared to control mice and thus show increase in number of visits or the time spent in the center. Different measures to evaluate anxiety in the open field paradigm are: total distance covered and the total time spent or entries made by the animals to the center arena.

*Apparatus:* The apparatus comprised of a square arena (50x50x35 cm) with a dark floor and black acrylic glass walls. Test was carried out in red light.

Test mice were placed in the center (a medial square 12.5 cm away from the walls) of the apparatus during the start of the experiment. The distance covered by the mice, the center entries and the center time was recorded during a 20 min test session. Animal activity was recorded and monitored by the camera vertically placed above the open field apparatus. The output was automatically recorded using the Any-Maze software.

#### 3.2.1.2. Light and dark avoidance test:

The principle reason for the test is to measure the ingrained aversion of the rodents towards the brightly light areas and the spontaneous exploratory innate behavior of mice to mild stress (Bourin and Hascoet, 2003).

*Apparatus:* The test system comprised of a rectangular chamber with a 19x21 cm light compartment (100 lux) made of acrylic glass and equally sized dark

compartment (<1 lux) of opaque black acrylic glass (Laxmi et al., 2003). The two compartments, was separated by an opaque black acrylic glass wall with a 3.7x4 cm opening at the bottom. The opening allowed the test animal to freely change and opt between the compartments.

At the beginning of the test session the animal was placed in the light compartment. During the test session (duration 5 min) both activity and the time spent by the animal in either of the compartments, was recorded using a photo-beam detection system.

### *3.2.1.3. Marble burying test (repetitive behavior):*

Marble burying test is used both as an indicator for anxiety similar behavior and obsessive compulsive like behavior. The test measures the burying behavior during which the rodent displaced the bedding material both with its forepaws and snout in an attempt to cover an object (Pinel and Treit, 1978). The burying behavior is often displayed in response to aversive stimuli or non-aversive unconditioned objects, like food, pellets and glass marbles. The marble-burying test takes the advantage of the inherent burying behavior to assess the number of novel, but innocuous, glass marbles the test rodent would bury (Thomas et al., 2009).

*Apparatus:* The test mice were placed in a clean cage (40x17x15 cm) with fresh bedding 5 cm high. 15 marbles were placed equidistant in a 3x5 arrangement in the middle of the cage.

The test session was of 30 min duration and the number of marbles buried was manually recorded after every 10 min (Silverman et al., 2010).

### **3.2.2. Social interaction paradigm:**

Social interaction is an innate and critical for the formation of societies and reproduction but even at an evolutionary level (Kaidanovic-Beilin et al., 2011). The paradigm I used to measure social behavior was the three-compartment paradigm. The test is also known as Crawley's sociability and preference for the

social novelty protocol. This protocol has been widely used to study both social affiliation and social memory in many mutants and inbred lines (Kaidanovic-Beilin et al., 2011). The main principle of the test is to measure the time spent by the mice with the interacting partner during the test and to quantify social tendencies.

### 3.2.2.1. One-interaction partner test:

This test aimed to validate the social affinity and quantify the social behavior with unfamiliar male mouse.

*Apparatus:* Three compartment apparatus was used which consisted of a grey opaque box (41.5x30.5x61.5 cm) divided into three interconnected compartments (each compartment: 19.8x41.5 cm)(Fig. 6. A). The outer compartments were identical and separated from the center compartment by two clear plexiglass partitions with a centrally placed opening in the bottom (6x6 cm). Wire-mesh cylinders (12.5x7.5 cm, closed at the top with a lid) (Fig. 6. B), was used for controllable exposure to the social interaction partners were placed in the center of each outer compartment (Silverman et al., 2010).

The test comprised of two phases an initial habituation phase followed by a testing phase. During the habituation phase (duration: 5 min) the test animal was placed in the center compartment and allowed to explore freely all the three compartments with the empty wire mesh tubes. Unfamiliar naive C57Bl/6 male mice of the same age like the test mice were used as interaction partners. The animals used as social stimuli were not repeated within the same group. The interaction partner was randomly placed in either of the compartments to avoid any compartment preference by the test mice. Though interaction partners had no prior exposure to the test compartment but they were extensively handled. In any chance the interaction partner showed escape like behavior or involuntarily entered the tube conditions the animals were omitted from the test.

Animal behavior during the test session was recorded for a period of 10 min, using a camera positioned directly above the apparatus. Exploration was

automatically measured and scored with Any-maze software. Additionally, manual scoring was done for direct contacts: the number and time of direct contacts with either of the tubes by the test mice were evaluated. Zone entries and time spent within each zone was automatically measured with the Any-maze software.

Preference index were calculated as:  $[(\text{Number of contacts with tube: animal} - \text{Number of contacts with the tube: empty}) / (\text{Number of contacts with tube: animal} + \text{Number of contacts with the tube: empty})] * 100$ .

To avoid any olfactory cues from the previous test mice, the apparatus was cleaned with 70 % ethanol and then thoroughly with water and allowed to dry. All the tests were done in a separate testing room in 100 lux of light intensity.

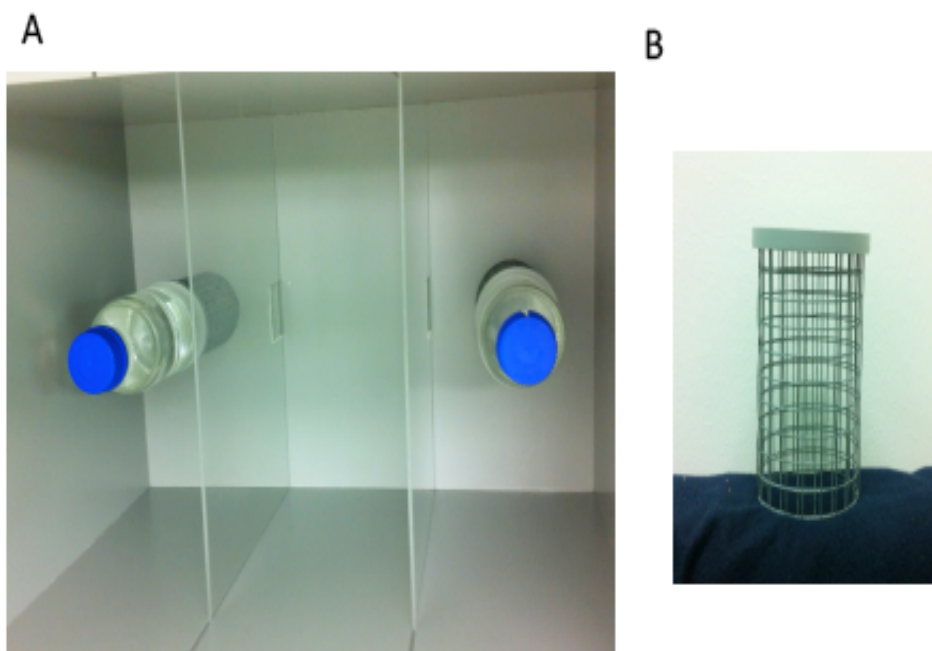

**Fig. 6.** The three compartment apparatus used for the social interaction paradigm (A). The wire mesh cylinder used to control the interaction and exposure of the social stimuli (B).

### *3.2.2.2. Male and female interaction test:*

This test was designed to validate the social affinity, social distinction and preference between the two genders. This test addresses the function of both the social and sexually motivated behavior.

*Apparatus:* The male and female interaction test was carried out in the three compartment apparatus similar to the apparatus used in the one interaction partner test.

The test consisted of two phases with an initial phase of 5 min called habituation phase similar to the one partner test and 10 min of test session. During the test session an unfamiliar naïve C57Bl/6 male and female mice were randomly placed in either of the outer compartment. In the beginning of the test session test mice was placed in the center compartment. Total number of direct contacts and time spent was recorded and manually scored with Any-maze. The preference index was calculated in similar manner as discussed in one-interaction partner test.

### **3.2.3. Olfactory test:**

Olfactory information is critical for mouse behavior like navigation, predator avoidance, bond formation, kin identification, mating, foraging, territorial marking and parental behaviors. Most of the olfactory tests use cues, that question the social choice made by the animal or are associated with learning and memory. Olfactory assessment is critical for the correct interpretation of mouse behavior related to the animal's social domain (Yang and Crawley, 2009).

#### *3.2.3.1. Non-social sensitivity test:*

This test consists of sequential presentations of different odor dilution to the test animal. The test was aimed towards checking the sensitivity of the olfactory

function by testing how well the animals recognize the change in the odor dilution.

*Apparatus:* The test apparatus used was the three-compartment chamber described earlier in the one interaction partner test. Odor was contained in a sealed petri dish (100x20 mm) with 25 holes perforated at equidistance on the cover of the dish. Rose odor was used to check for the non-social odor sensitivity. Rose odor (rose essence, diluted 1:100) was diluted in double distilled water in different ratios of  $1 \times 10^{-6}$ ,  $1 \times 10^{-4}$ ,  $1 \times 10^{-2}$  and  $1 \times 10^{-1}$  and for the neutral odor water was used. 100  $\mu\text{L}$  of the odor solution (rose/ water) was applied to filter paper (2x2 cm) placed in the center of the petri dish. During the test the petri dish was placed randomly in the center of either of the outer compartment (Fig. 7.).



**Fig. 7.** The three compartment apparatus with clean bedding placed at the start of the habituation phase. The animal was placed in the center chamber during the beginning of the test.

The first phase of the test was the habituation phase (duration: 5 min) during which the test mice were allowed to explore the chamber and the petri dishes with

the neutral odor. This was followed by test sessions, which was of 5 min duration each. The test animal was allowed to explore both diluted rose odor and neutral odor (water) placed in the outer chamber. Animals were first exposed to the highest diluted rose odor solution  $1 \times 10^{-6}$  on one side and the neutral odor on the other side. After every 5 min of the test session the animal was exposed to the next higher concentration in the series  $1 \times 10^{-4}$ ,  $1 \times 10^{-2}$ ,  $1 \times 10^{-1}$  dilution factors. Each odor was placed randomly both during and within the test session to avoid any preference. The animals were exposed to series of dilution till the maximum concentration of the rose odor i.e.,  $1 \times 10^{-1}$ . Test animals activity was recorded during the test by a camera positioned vertically above the apparatus. The recorded data was analyzed with Any-maze software. The test was carried out at 5 lux of light intensity. The preference index was calculated in similar manner as discussed in one-interaction partner test.

#### **3.2.4. Pheromone sensitivity test:**

The pheromone sensitivity test consisted of exposure of the test mice to a series of female urine sample at different dilutions. The test carried out was to validate the olfactory function and recognition of female urine odor and affinity towards the odor.

*Apparatus:* The test design was similar to the previously described protocol used for the rose sensitivity test. Series of odor dilutions used were  $1 \times 10^{-4}$ ,  $1 \times 10^{-2}$ ,  $1 \times 10^{-1}$  and 1. All the samples were diluted with double distilled water and freshly prepared 1 h prior to the test.

Fresh urine was taken from 3 months old adult C57Bl/6 unfamiliar diestrus female mice. The females were visually inspected one day prior to the test for the phase they were in i.e., diestrus phase and not active phase (Byers et al., 2012). Urine was collected in a 1.5 mL eppendorf tube by gentle rubbing and stroking the lower abdomen of the mice. Pheromones in the urine samples are highly unstable and volatile and hence were stored in the freezer at  $-20^{\circ}\text{C}$ .

The test method and calculation was similar to the method used for the non-social sensitivity test.

### **3.2.5. Social odor and non social odor test / male versus female bedding odor test:**

The test was designed to assess the ability of the test animals to differentiate between the two odors they were exposed to. According to the innate behavior of the animals for social recognition and mating, animals would opt for a familiar odor or an odor from the same species (social odor) compared to unfamiliar odor. Animals were exposed to different beddings and olfactory stimuli to validate their preference for specific social odors (Silverman et al., 2010).

*Apparatus:* The apparatus was similar as describe in olfactory sensitivity test. The test protocol was similar to social interaction paradigm, with 5 min of initial habituation immediately followed by 10 min of testing session. Petri dishes used were similarly prepared as mentioned previously for odor sensitivity test. One-week old bedding material from C57Bl/6 unfamiliar 3-5 mice (male or diestrus phase female depending on the test) grouped together was used for the social odor assessment. While for the non social odor test, rose essence; diluted 1:100 to double distilled water was used. The petri dish was sealed and placed at the centre of the outer chamber.

Test animal was placed in the centre compartment in the beginning of each test session. Recording and evaluation of behavior was similar as mentioned for social interaction test.

### **3.2.6. Aggression test:**

#### *3.2.6.1. Resident intruder aggression test:*

The test measures the residential animal's response towards a conspecific intruder. Often this interaction between the two male mice: resident and intruder mice



result in heavy fighting as per the natural territorial instincts (Koolhaas et al., 2013). Aggressive behavior during this test include investigation, threats, fighting, approach, chasing and dominant posturing. The outcome of such interaction is modulated by the age and hormonal status of the resident mice (Olivier and Young, 2002).

*Apparatus:* The test was carried out in the home cage of the test mice.

The resident mice were housed individually for 4 weeks prior to the test. The home cage of the resident mice was not cleaned one week prior to the test date. Animals underwent 10 min of acclimatization to test conditions of the test room, followed by confrontation with a six to eight week old, group-housed male C57Bl/6 intruder in a single 5 min test session in the resident cage. Latencies for the first frontal contact and anogenital sniffing, mounting and first attack as well as number of mounts, chases and attack (Fig. 8.) were measured manually (Stork et al., 2000). The test took place at 5 lux of light intensity.

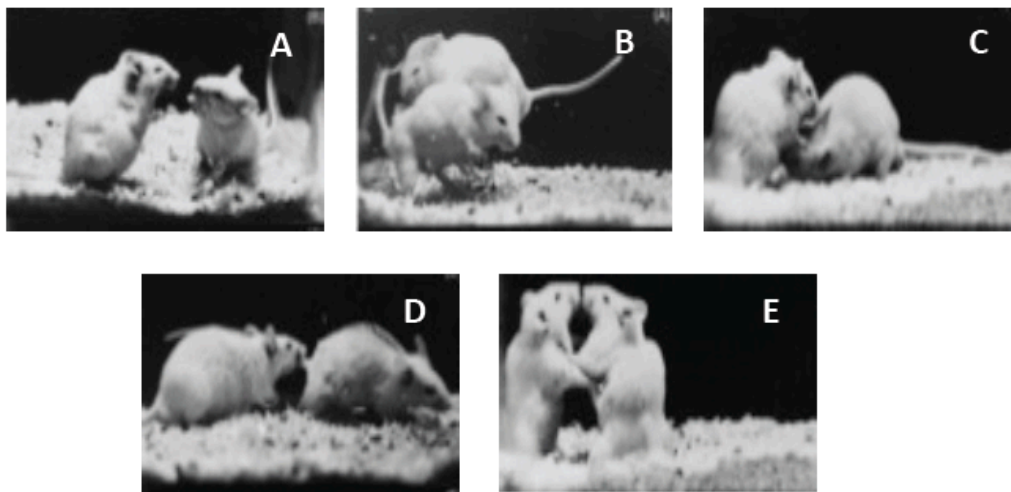

**Fig. 8.** Showing the different aggressive behavior measured during resident-intruder aggressive test: mouth contact (A), mounting (B), anogenital sniffing (C), chasing (D) and attacks (E).

### 3.2.7. Nest building:

Nest is critical for the rodents for reproduction and shelter. Nesting behavior is very sensitive to various components such as pharmacological agents, genetic mutation, brain lesions and olfactory impairment (Deacon, 2006).

*Apparatus:* The test was carried out in the home cage of the mice.

During the test, animal was placed in a clean cage with no bedding material. Weighed nestlets<sup>7</sup> of 2.2 g standard weight were placed in the food hopper of the home cage of the mice, 1 h before the beginning of the dark phase. At different time points (0min, 90min, 3 h, 6 h, 12 h and 24 h) the nestlets left behind by the mice were recorded and the quality of the nest constructed was scored according to an established scale (Fig. 9.) (Albrecht and Stork, 2012; Deacon, 2006).

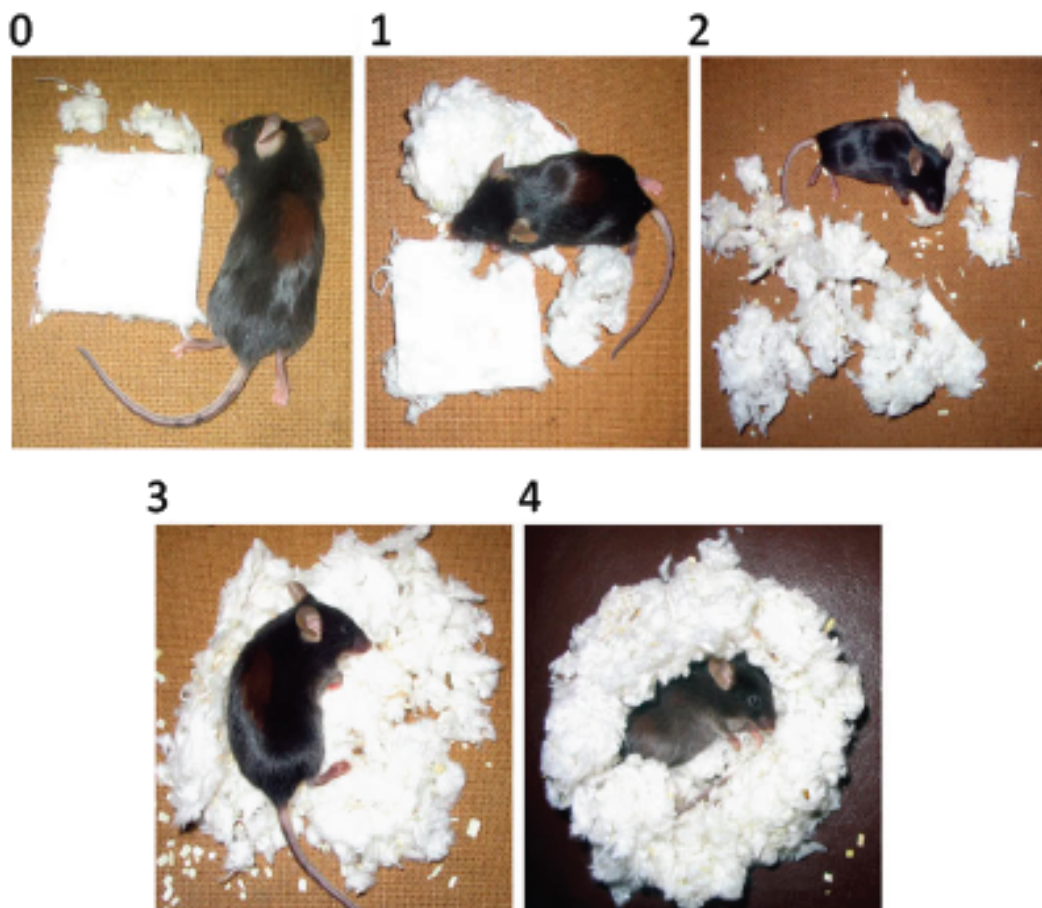

**Fig. 9.** Showing the different nest build quality with the corresponding scoring. on

<sup>7</sup> They are pressed cotton pellets, which are often used as nesting material for laboratory rodents.

top left of each picture for nest quality assessment.(Deacon, 2006) .

The quality of the nest was scored according to the scoring system mentioned below (Fig. 9.):

0—no nests,

1—primitive flat nests (pad-shaped, consist of a flat paper tissue which slightly elevates a mouse above the bedding),

2—more complex nests (including warping and biting of the nestlets),

3—complex accurate cup-shaped nests (with shredded paper interwoven to form the walls of the cup),

4—complex hooded nests, with walls forming a ceiling and a hollow sphere with an opening

### **3.2.8. Fear memory test:**

*Apparatus:* The training apparatus consisted of a chamber with 36x21x21 cm dimension and a grid floor to deliver electric foot shocks to the test mice. The test chamber composed of an isolated cubicle containing a speaker, with a ventilator attached with dual function of air circulation and background noise of 70 dB (Laxmi et al., 2003).

Test animal was habituated for first two days by placing the animals in the training apparatus and a set of three acoustic stimuli were given to the animal of 2.5 kHz with a duration of 10 s and with an interval pause of 20 s (Fig. 10. A). This formed the CS stimuli referred to as the conditioned stimuli. On the third day the test mice were trained for the unconditioned stimuli (US), which consisted of three acoustic stimuli of 10 kHz (9 s) which were coupled with 0.4 mA electric shock (1 s) with alternative pause intervals for 20 s (Fig. 10. B). During both the habituation and training the animals had initial 2 min and in the end 2 min without stimulus presentation. The fourth day consisted of retrieval phase, which took place in two different conditions as under mentioned (Laxmi et al., 2003)(Fig. 10. C).

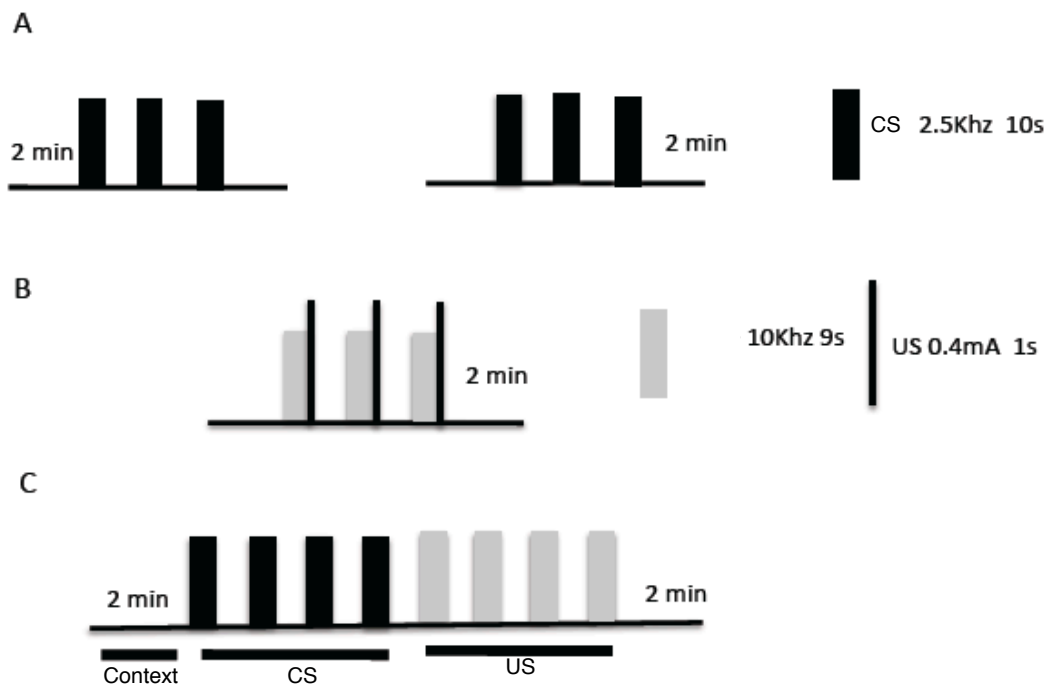

**Fig. 10.** The diagrammatic representation of the different stimuli and phases carried out during the fear condition paradigm: Habituation (A), training (B) and retrieval (C) phase.

#### 3.2.8.1. Neutral context:

During retrieval stage test animal was placed in the neutral cage (clean cage similar in dimension to the home cage but with fresh bedding). The retrieval test consisted of 2 min exposure both in the beginning and at the end of the test. This was followed by initial four acoustic stimuli 2.5 kHz (CS) and soon after followed by four 10 kHz (US uncoupled with the electric shock) acoustic stimuli over the duration of 10 s. All the acoustic stimuli were separated by 20 s of pause. The test animals used for retrieval in the neutral context had no prior exposure to the retrieval in the shock context.

#### 3.2.8.2. Shock context:

Test animals during the retrieval stage were placed in the chamber where the animals were previously trained. The retrieval test was similar to the test mentioned above in neutral context. The test animals used for the shock test retrieval were not exposed to neutral context retrieval session.

### **3.2.9. Home cage activity:**

The test assesses the behavior in freely acting animals, as they provide information on numerous innate behaviors and physiological systems (thermal status, sleep, reproduction, defense, energy balance and environmental responses). The protocol I used for the test was aimed to examine animal in a controlled environment especially between two discrete states: inactive (ISs) or the light phase and active state (As) or the dark phase. It has been observed that during the active state animal engage in behaviors like foraging and patrolling within the cage. On the other hand, in inactive phase animals engage in rest, sleep and refuge related behavior (nest or burrowing)(Goulding et al., 2008).

*Apparatus:* Single caged animals were transferred to new cages with no additional bedding material. Each cage had an infrared reader placed directly above the grid. The sensor recorded the animal activity after every 15 s.

Naïve animals soon after separation were housed in the single cages. After 24 h the activity of the animals was measured for a period of 72 h. The measured activity was recorded and analyzed in 5 min bin.

### **3.2.10. Urine marking test:**

This test is used to assess social behaviors like individual recognition, social stress, dominance quantification and reproduction behavior (Drickamer, 2001).

*Apparatus:* It consisted of a clean cage, which was lined with filter paper of the dimension 32x15.5 cm at the bottom of the cage.

Test mice were placed in the center of the lined cage and placed in the experiment room for 60 min at 5 lux of dim light. Soon after the test the filter paper was collected and generously sprayed with 0.1% ninhydrin spray under the hood. The sprayed filter paper was allowed to dry under the hood to facilitate the development of urine marks through the interaction of ninhydrin with the protein present in the urine. After 24 h of drying, the filter papers with urine markings

were scanned and quantified with ImageJ software and scored (Drickamer, 2001). All the mice used were naïve with no prior exposure to any behavior experiment.

Center area urine marking quantification: For the center area urine mark quantification a rectangle of the dimension 28x12 cm was marked in the center of the filter paper. The urine marks lying in the rectangle were counted to measure the dominance behavior. This method was used to investigate the effects of phytoestrogens in social behavior.

### **3.3. Immunohistochemistry:**

Immunohistochemistry works on the principle of specific binding of the antibodies to the antigens in the biological tissue. It is a widely used method for the quantification of the protein at cellular levels. Preparation of the sample requires proper tissue collection, fixation and sectioning. The visualization of an antibody-antigen interaction is accompanied by various ways depending on the conjugant to antibody: peroxidase enzyme. The other means is the antibody tagged to a fluorophore, as rhodamine and fluorescein.

#### **3.3.1 Perfusion of the adult mouse:**

Adult male mice were deeply anaesthetized with a mixture of Ketamin and Rompun (4:1 100 µL, intraperitoneal). Animals were pinched on the tail and sole to check if they were unconscious. Animals were perfused transcardially with 50 mL of Tyrode buffer (with 0.2 % Heparin). This was followed by fixation with 4 % paraformaldehyde (approx. 200 mL) was pumped into the animal. Post fixation the animals were decapitated and the brain was extracted and stored overnight in 4 % paraformaldehyde (PFA) at 4 °C. Later incubated for 3 days in 30 % sucrose for cryoprotection followed by snapped freeze with methylene butane<sup>8</sup> and stored at -80 °C.

---

<sup>8</sup> Methylene butane was lowered to -80 °C with the help of liquid nitrogen. As soon the temperature was attained the brains embedded in frost-tek were transferred.

### **3.3.2 Preparation of cryo-sections:**

The frozen brains were thawed from -80 °C to -20 °C by incubation at -20 °C for 1 h prior to the cryo sectioning. Cryo stat was set to object temperature at -18 °C and cryo temperature at -20 °C. The slicer was adjusted for the required section thickness and the brain was fixed on the objective with frost-tek. 30 µm thick coronal sections were collected in each well containing 0.1 M phosphate buffer (PB) with 0.02 % sodium azide of the 24 well-plate. Alternate sections were collected in adjacent wells and store at 4 °C in 0.1 M PB.

### **3.3.3 Preparation for GFP quantification:**

5 brain sections per animal were collected in each well of the 24 well-plate. Sections were collected in 0.1M PB. This was followed by washing the sections three times with 1 mL of 0.1 M PB for 5 min each on the shaker.

The washed sections were treated with 500 µL of 10 % sodium-thio sulphate solution per well. The sections were incubated for 30 min at room temperature to quench any auto-fluorescence. This was followed by the washing step, which was repeated 3 times for 5 min each with 0.1 M PB.

The washed sections were transferred on to the objective slide with a brush under a binocular microscope.

The sections were allowed to dry as they were incubated on the hot plate at 25 °C for 30 min.

The dried sections were mounted with Immuno Mount™ and allowed to dry in the dark on a cool plate, labeled and stored at 4 °C.

### **3.3.4 Single cell GFP quantification:**

Green fluorescence protein (GFP) is a 26.9 kDa protein, emits green fluorescence when exposed to ultraviolet light. GFP gene is widely being used both in molecular and cell biology as a reporter of expression. In this method, I used GAD67-GFP mice which are constructed with GFP insert downstream of the GAD67 promoter. The GFP was used to quantify the expression of the GAD67 in

different brain regions. Fixed sections from the dorsal region with amygdala in the plane (Bregma: -1.22 to -1.82 mm) were used for the GFP quantification. The epifluorescence microscope was used for the GFP quantification. 5x objective lens magnification was used for visualization and capturing of the images for the GFP quantification. The software Leica Microsystems-Leica Applied System (LAS)-AF 2.3.0 Build 5131 was used for quantification and picture capture. GFP quantification was done at two levels: one was the region quantification where with a free hand tool the outline region of interest i.e., lateral, basolateral and central amygdala was marked and the total GFP emitted was measured. The total GFP fluorescence per region (N=10 sections per animal) was quantified with the free hand's tool with the software.

The other measure was the single cell quantification where the outline of GFP emitting cells were marked and the total GFP emitted signal was measured. All the settings for exposure and grey values were kept constant between all the images captured with the microscope.

After the desired cell or region was marked. The grey value and the area marked were tabulated and recorded for further assessment. For the analysis of individual cells 40 cells per section were selected at random. All the detection parameters were kept constant across measurements.

### **3.3.5 c-FOS immunohistochemical staining:**

c-FOS, an immediate early gene<sup>9</sup> and rapidly induced within 15 min of stimulation. The gene is being used to quantify the activation of the associated region or cellular process with the stimuli.

Mice exposed to the one partner social interaction test were used for c-Fos immunohistochemistry to investigate the activation of different regions associated with social behavior. One hour after the test the mice were anesthetized and perfused. The brains were rapidly removed from the skull and kept in fresh 4 % paraformaldehyde for 24 h before being transferred to a solution of 30 % sucrose in 0.1M PB, pH 7.4 for 72 h. 30 µm thick coronal sections from the rostral end of

---

<sup>9</sup> These genes are which are activated rapidly in response to cellular stimuli.



the olfactory bulb towards the caudal end of the amygdala were cut on a freezing microtome (Olfactory subregions: Bregma 3.92 to 3.56 mm; Forebrain: Bregma 0.38 to 0.14 mm and Amygdala: -1.34 to -1.70mm). Sections were washed three times in 0.1 M PB and then without any prior blocking incubated with 0.1 M PB/0.3 % Triton containing 2 % normal goat serum and polyclonal rabbit anti-c-Fos primary antibody (1:1000 dilution) for 48 h at 4 °C. Sections were washed three times with 0.1 M PB and then incubated for 2 h with biotinylated anti-rabbit secondary antibodies, c-Streptavidin Cy3 (1:1000) in 0.1 M PB/0.3 % Triton at room temperature. The sections were washed twice for 10 min with 0.1 M PB and counterstained for 5 min with 300 nM DAPI. After three final washings with 0.1 M PB, the sections were transferred onto the glass slides, air-dried and embedded with Immuno Mount®. Fluorescence images were captured with epifluorescence microscope.

The number of c-Fos stained profiles was determined in different brain regions related to the regulation of social behavior. c-Fos and DAPI positive profiles were identified manually and the area was marked using the ImageJ cell counting tool. The prominent c-Fos labeling in the granule cell layers of the olfactory and accessory olfactory bulb and in the glomeruli of the olfactory bulb was evaluated at random positions in square fields of 40x40 mm, placed 90° perpendicular to the midline of the dorsal olfactory bulb. c-Fos-positive profiles were further quantified in the cortical and medial amygdala, bed nucleus of the stria terminalis, medial preoptic area and the lateral septum as they are critical for components of the circuitry controlling social behavior (Franklin and Paxinos, 2008). For each region, the number of stained profiles was determined in three non-adjacent sections from both the left and right hemispheres. Cell numbers were divided by the area of analysis and averaged for each subject.

### **3.4. Brain tissue laser-capture:**

#### **3.4.1. Preparation of the PLL (poly-L-lysine) coated glass slides:**

Poly-L-Lysine was used to facilitate the brain tissue to adhere to the objective glass slide surface during laser dissection and capture.

Membrane glass slides were treated with UV light for 30 min duration in order to sterilize the slide. The sterilized slides were generously coated with 1 mL of poly-L-lysine and incubated for 30 min at room temperature. The treated slides were washed three times for 5 min each with double distilled water and allowed to air dry at room temperature.

RNAse treatment: Slides were generously sprayed with RNAse free spray on the membrane side and incubated for 2 min. This was followed by series of washings for 5 times and 5 min each with DMDC (dimethyl dicarbonate) treated double distilled water. This was followed by air-drying of the slides and storage for further application at room temperature.

#### **3.4.2. Preparation to freeze fresh brain for tissue capture:**

Animal was deeply anaesthetized with dosage of isoflurane and later killed through the method of cervical dislocation and followed by decapitation of the head. The fresh brain was extracted, placed in an aluminum mold and embedded in frost-tek. This was followed by snapped freezing of the brain tissue in methylene butane at -80 °C and further storage at -80 °C.

#### **3.4.3 Preparation of the cryostat section for laser-capture:**

Fresh frozen brains were thawed from -80 °C by 1 h incubation at -20 °C before cryo sectioning. Objective of the cryo was set at -16 °C and the chamber at -18 °C. The brain was fixed with frost-tek on the holder and the slicer was adjusted to 20 µm thickness. 10-12 sections were collected from the dorsal region with amygdala

(Bregma: -1.22 to -1.82 mm) was mounted on the poly-l-lysine-coated membrane slide. The slides were placed on the UV-light treated (2 h) hot plate (40 °C) after each section was mounted.

#### **3.4.4 Tissue mRNA fixation for laser-capture:**

The sections were heated on the hot plate at 40 °C for 30 min time. The dried sections were treated with -20 °C cold 70 % ethanol (in DMDC treated double distilled water) for 2 min. This was followed by staining of the sections with cresyl violet solution to facilitate better visualization of the cells during the capture. This was achieved by treating the sections for 2 min with 1% cresyl violet solution in 50 % ethanol (DMDC double distilled water at 4 °C). To remove excess staining, the sections were treated with 70 % ethanol (DMDC double distilled water at 4 °C) for 2 min. This was followed by the final fixation step during which sections were treated for 1 min with 100 % ethanol (4 °C).

#### **3.4.5 Parameters for micro-dissection:**

The mounted sections were placed on the slide loader on the axiovert 200M Inverse Microscope. Software was used for the viewing and capturing of the tissue. The desired region was selected and focused at 5x magnification. With the help of the free hand tool the region was marked and the collector was loaded. Cutting was carried out with laser energy intensity of 80 % and capture intensity of 90 %. AutoLPC i.e; automated cutting and capturing was carried out (Fig. 11.). After every capturing the executed region was reviewed to validate a proper and complete collection. For each region 10-12 sections were used and tissue was collected bilaterally. The collector was marked and stored in ice and further processed for mRNA isolation.

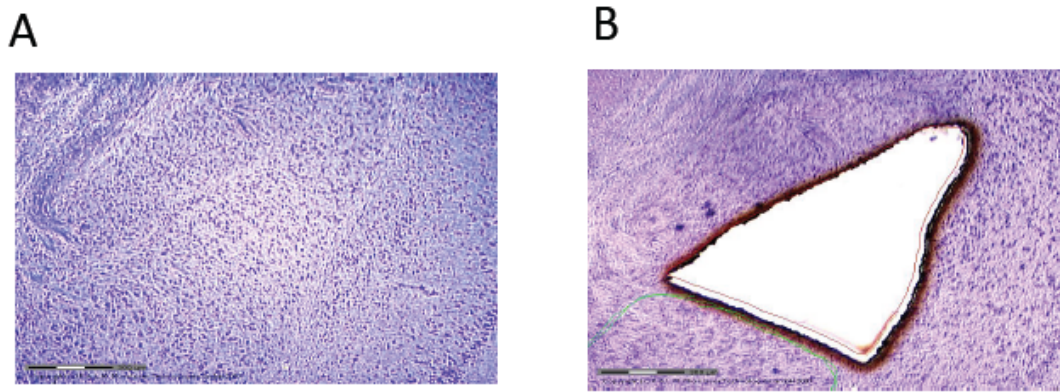

**Fig. 11.** 5x magnification showing the lateral amygdala during the laser capture. The region in focus before the capture (A) and after the tissue had been captured (B).

#### **3.4.6 Protocol for mRNA extraction and reverse transcriptase:**

The captured tissue per area per animal was collected in the collector eppendorf tube. 350  $\mu$ L of the RLT plus buffer with 50  $\mu$ L of  $\beta$ -mercapthenol was added to the tube. The tube was vortex for 30 sec to facilitate proper mixing. The tissue containing tube was incubated on ice for 30 min in an inverted fashion. This was followed by centrifugation at 10,000 rpm for 5 min in order to spin down the lysate. After centrifugation the tube was stored at -80  $^{\circ}$ C.

For first-strand synthesis of cDNA a two-step-approach was performed, according to the “Cells-to-cDNA II” Kit. During the initial step 5  $\mu$ l of the lysate was mixed with 11  $\mu$ l of reverse transcription mix 1 containing dNTPs and oligonucleotide primer and incubated at 70 $^{\circ}$ C for 3 min in a thermocycler, enabling heat denaturation of secondary structures of the template RNA. After cooling on ice and subsequent brief centrifugation, 4  $\mu$ l of mix 2 were added containing the reverse transcription enzyme in the appropriate buffer as well as an RNase inhibitor (Table. 2.9.). The cDNA synthesis was conducted in 50  $\mu$ l PCR tubes in a thermocycler at 42 $^{\circ}$ C for 60 min followed by enzyme inactivation at 95 $^{\circ}$ C for 10 min. The cDNA samples were stored at -20 $^{\circ}$ C until real time PCR was conducted.

**Table 2.9.** Master Mix 1 & 2 for Reverse Transcription reaction

|               |           |   |
|---------------|-----------|---|
| <b>Mix 1:</b> | 5 $\mu$ l | Lysate  |
|               | 4 $\mu$ l | dNTP Mix (2.5 mM each)                        |
|               | 2 $\mu$ l | Oligo (dT)18 first strand primer (50 $\mu$ M) |
|               | 5 $\mu$ l | RNAse free water                              |
| <b>Mix 2:</b> | 2 $\mu$ l | 10x RT-Buffer                                 |
|               | 1 $\mu$ l | M-MLV Reverse Transcriptase (100 U/ $\mu$ l)  |
|               | 1 $\mu$ l | RNAse Inhibitor (10 U/ $\mu$ l)               |

### 3.4.7. Real time PCR (polymerase chain reaction) protocols

The real time (RT) PCR or quantitative chain reaction is based on the standard DNA amplification by thermo-cycler. The normal DNA amplification in the real time PCR is followed by detection of the product. The sequence specific DNA oligonucleotides labeled with fluorescent reporter permits detection only after hybridization to the specific sequence. The method is based on DNA-based probe with a fluorescent reporter at one end and on the other end a fluorescent quencher. The close proximity of both prevents detection of the fluorescence. Binding and further breakdown of the probe by the Taq polymerase 5' to 3' exonuclease activity results in the emission of fluorescence.

With each PCR cycle, more reporter dye was unleashed and the fluorescence signal intensity increases proportional to the amount of amplicon. Thereby quantification is based on the principle high number of cDNA at the beginning of the PCR will produce an increase of fluorescence significantly above background levels after relatively few PCR cycles (the so called cycle threshold, CT) while low numbers of template will need more PCR cycles until the fluorescence signal reaches threshold level (VanGuilder et al., 2008).

I used pre-designed assays for GAD67, 65, NPY, SST and the housekeeping gene phosphoglycerate kinase (PGK) provided by Applied Biosystems (TaqMan® Gene expression assays, Applied Biosystems, Darmstadt, Germany). As described above, based on TaqMan chemistry the assays contain next to the gene-specific

primer sequences the TaqMan MGB (minor groove-binder) probe with a non-fluorescent quencher (NFQ) and 6-carboxy-fluorescein (FAM) as a fluorescence dye. The TaqMan Universal Master Mix (Applied Biosystems, Darmstadt, Germany) provided the PCR components needed with AmpliTaq Gold DNA Polymerase, dNTPs with UTP and optimized buffer. All assays were run on the samples in triplicates with the reaction setup described in table 2.10.

**Table 2.10.** Reaction setup for Real-Time-PCR

| Reaction mixture                       | Volume |
|--|--------|
| cDNA 1:5 dilution                      | 1.5 µl |
| 2x TaqMan ® Universal Master Mix       | 5 µl   |
| 20x assay (GAD65, 65, NPY, SST or PGK) | 0.5 µl |
| RNAse free water                       | 3 µl   |

All runs were performed in the ABI Prism 7000 Real-Time-PCR system according to the thermocycler program (Table 2.11.).

**Table 2.11.** Thermocycler program for the real time PCR

| Stage                  | Temperature and time |            |
|------------------------|----------------------|------------|
| Holding stage          | 50 °C for 2 min      |            |
|                        | 95 °C for 10 min     |            |
| Cycling stage          | 95 °C for 15 s       | X 50 times |
|                        | 60 °C for 1 min      |            |
| Infinite holding stage | 4 °C for infinite    |            |

### 3.4.8. Calculation and analysis:

Using the ABI Prism Software the mean cycle threshold (CT) values were determined for each triplicate assay. Relative quantification of GAD67/65/NPY/SST mRNA levels was conducted according to the dCT method (Livak and Schmittgen, 2001). I normalized the quantified gene (GAD67, 65, NPY or SST) to the overall content of cDNA in a sample by using PGK as an internal control. During the initial standardization it was confirmed that PGK expression was independent of treatment groups and referred only to the starting amount of DNA in each sample. The dCT, i.e., the normalized raw values of the gene expression was subtracted from the relative house keeping gene expression value. Here I am using GAD67 as an example reaction:

$$\text{dCT (GAD67)} = (\text{mean CT (GAD67)}) - (\text{mean CT (PGK)})$$

The dCT was calculated for each sample, for all the four genes (GAD67, GAD65, NPY and SST) with different diet conditions and from different subregions of amygdala.

Since Real time PCR is based on an exponential function, the dCT value for each group was transformed in the Relative Quantification value (RQ):

$$\text{RQ} = 2^{-\text{dCT}(\text{gene expression})}$$

Firstly, the different relative expression values of the gene (GAD67, GAD65, NPY and SST) were evaluated in the single areas (lateral and basolateral amygdala). Differences in expression between distinct conditions were determined with an one-way-ANOVA for the factor area followed by *post hoc* test.

### 3.5. ELISA quantification

ELISA kit is based on the competition principle, i.e., both the sample antigen and a fixed amount of the enzyme labeled antigen compete for the binding sites of the

antibodies coated on the well surface. The intensity obtained by the end of the reaction is inversely proportional to the amount of the antigen in the sample.

### **3.5.1. Serum preparation from the blood plasma**

Adult naïve male mice were deeply anaesthetized with isoflurane and underwent cervical dislocation. 22G needle was inserted into the left ventricle to collect the blood through the narrow tube attached to the needle, directly into the serum tubes.

Separation protocol: Collected blood was incubated in the SARSTEDT serum tubes overnight at 4 °C. Overnight incubation is critical to facilitate serum extraction. Adjacent day the serum tubes were centrifugated for 10 min at 13,000 rpm. The serum was collected, labeled and store at -80 °C.

Note: After collection the samples were kept on ice all the time. Frequent thawing of the serum was avoided as it interfered with the serum protein stability.

### **3.5.2. Estrogen ELISA measurement protocol:**

Serum samples were diluted in the ratio of 1:20. 100 µL of the standard (17β - estradiol Saliva kit), control and serum sample were added in duplicates to each well.

50 µL of the Estradiol antiserum was pipetted to each well, the plate was covered and incubated on a shaker (400-600 rpm) for 2 h at 25 °C. After incubation the content was discharged by tapping on tissue paper and washed 4 times with 250 µL of washing buffer (washing solution, 17β-estradiol Saliva kit).

100 µL of the substrate (TMB substrate solution, 17β-Estradiol Saliva kit) was added to each well and incubated for 30 min at 25 °C. Soon after 30 min 100 µL of the stop solution was added (TMB Stop Solution, 17β-Estradiol Saliva kit) to each well in order to stop the reaction. The optical density was measured at 450 nm within a time frame of 15 min from the addition of the stop solution. Result of the samples was determined directly using the standard curve (Fig. 12.; Table 2.12).



**Table 2.12.** The standard curve values for the 17 $\beta$ -Estradiol curve

| Standard              | Absorbance Unit |
|-----------------------|-----------------|
| Standard 0 (0 pg/mL)  | 1.8             |
| Standard 1 (5pg/mL)   | 1.6             |
| Standard 2 (10pg/mL)  | 1.4             |
| Standard 3 (50pg/mL)  | 0.8             |
| Standard 4 (100pg/mL) | 0.5             |

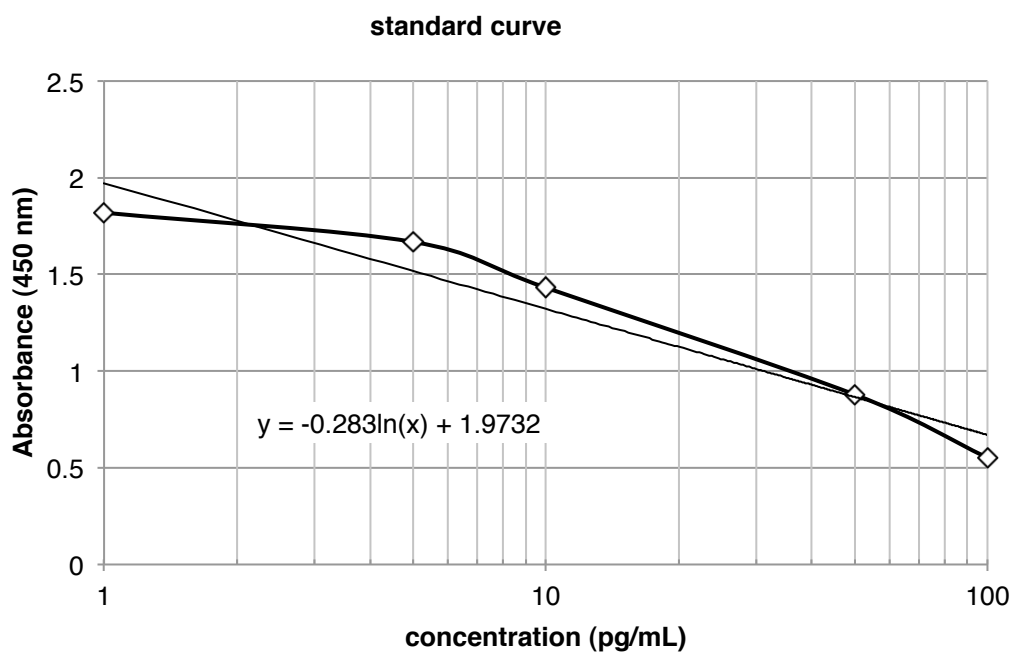
**Fig. 12.** The standard graph curve with the different standard sample in the 17 $\beta$ -Estradiol ELISA kit. The dots are the value of the standard sample.

### 3.5.3 Testosterone ELISA measurement protocol:

The principle and the protocol followed for the sample dilution were similar to one described in the Estradiol ELISA measurements.

50  $\mu$ L of the sample, standard and the control were added in duplicates to the respective well. This was followed by addition of 50  $\mu$ L of the enzyme conjugate (Testosterone Saliva ELISA kit) to each well. To this 50  $\mu$ L of the testosterone

antiserum was added and covered with an adhesive transparent foil and incubated for 2 h at 25 °C on a shaker (400-600 rpm). After incubation the contents were discarded and the plate was washed four times with 250 µL of wash buffer (Testosterone Saliva ELISA kit) and tapped on paper towel to remove the excess residue. 100 µL of the substrate solution (TMB Substrate Solution, Testosterone Saliva ELISA) was added and plate was incubated for 15 min at room temperature on an orbital shaker at 400-600 rpm. The final step was the termination of the reaction step by adding 100 µL of the stop solution (TMB Stop Solution, Testosterone Saliva ELISA) and optical density was measured with a photometer at 450 nm within 15 min from the time of addition of the stop solution.

Measurements were quantified in a similar way as mentioned earlier with the 17β - estradiol ELISA kit (Fig. 15; Table 2.13).

**Table 2.13..** The standard curve values for the Testosterone curve

| <b>Standard</b>        | <b>Absorbance Unit</b> |
|------------------------|------------------------|
| Standard 0 (6.4 pg/mL) | 2.2                    |
| Standard 1 (16 pg/mL)  | 2.0                    |
| Standard 2 (40 pg/mL)  | 1.6                    |
| Standard 3 (100 pg/mL) | 1.1                    |
| Standard 4 (250 pg/mL) | 0.7                    |
| Standard 5 (760 pg/mL) | 0.4                    |

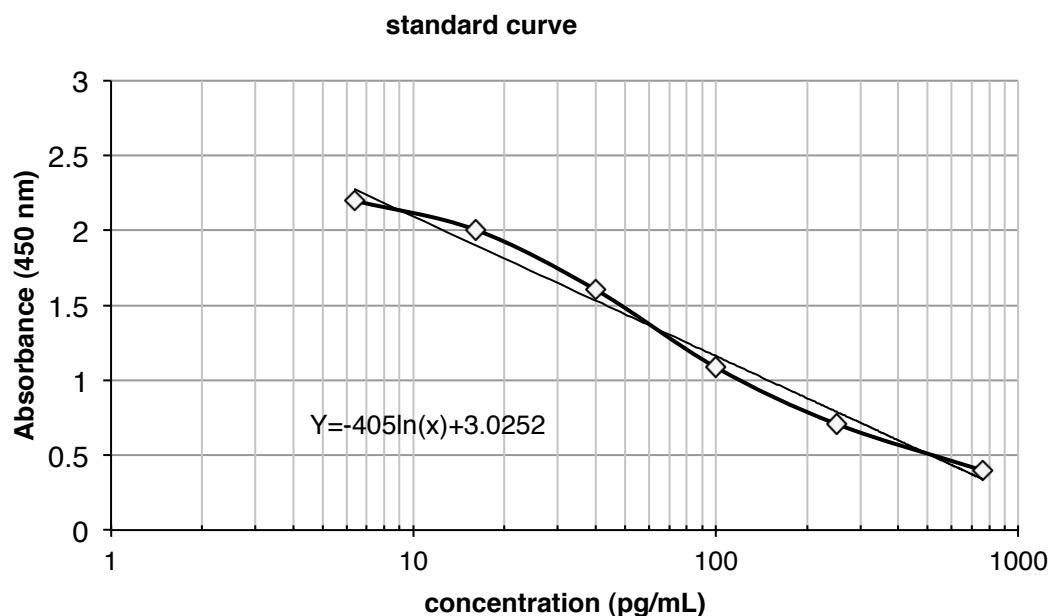

**Fig. 15.** The standard graph curve with the different standard sample in the Testosterone ELISA kit. The dots are the value of the standard sample.

### 3.5.4 Vasopressin ELISA measurement protocol:

Vasopressin ELISA quantification is based on the principle of competitive immunoassay to determine the vasopressin in the samples. The protocol uses vasopressin polyclonal antibody to bind in a competitive manner to vasopressin. The ELISA kit contains enzyme-linked antibody. During the initial step the labeled antigen competes with the sample antigen, which is unlabeled for the binding site of the primary antibody. Hence more the antigen in the sample, less labeled antigen is retained in the well and therefore the signal is weak and likewise a weak signal means low antigen level in the sample.

100  $\mu$ L of the sample duplicates were added to the well and appropriate dilutions as per the kit instructions were carried out for a standard curve. Then 50  $\mu$ L of the antibody (vasopressin kit antibody) was added to each well respectively except the blank well. The well-plate was covered and incubated at 4  $^{\circ}$ C for 24 h after gently mixing. After incubation the content was discarded and plates were washed with 400  $\mu$ L of washing solution (vasopressin kit washing buffer) three times. Each time during the wash the plate was tapped to ensure proper washing. In the next step 200

$\mu\text{L}$  of the pNpp (alkaline phosphate yellow) substrate (substrate available with the vasopressin kit) was added to each well and incubated at  $37\text{ }^{\circ}\text{C}$  for 1 h.

50  $\mu\text{L}$  of stop solution was added to each well to stop any further reaction. This is a critical step because reading should be done within 5 min since the stop reaction. Samples were read at the optical density at 405 nm, 570 nm and 590 nm with the Tecan I reader. The 405 nm is the optical density for the blank range so the value was subtracted from the mean value measured at 570 nm and 590 nm. Hence the standard curve was constructed (Fig.16. , Table 2.14)

**Table 2.14..** The standard curve values for the Vasopressin curve

| <b>Sample</b> | <b>Bound %</b> | <b>Vasopressin (pg/mL)</b> |
|---------------|----------------|----------------------------|
| Blank         | 0.00%          | -                          |
| Standard 1    | 6.2%           | 1000                       |
| Standard 2    | 10.5%          | 400                        |
| Standard 3    | 15.5%          | 160                        |
| Standard 4    | 30.6%          | 64                         |
| Standard 5    | 52.6%          | 25.6                       |
| Standard 6    | 73.2%          | 10.24                      |
| Standard 7    | 88.8%          | 4.10                       |

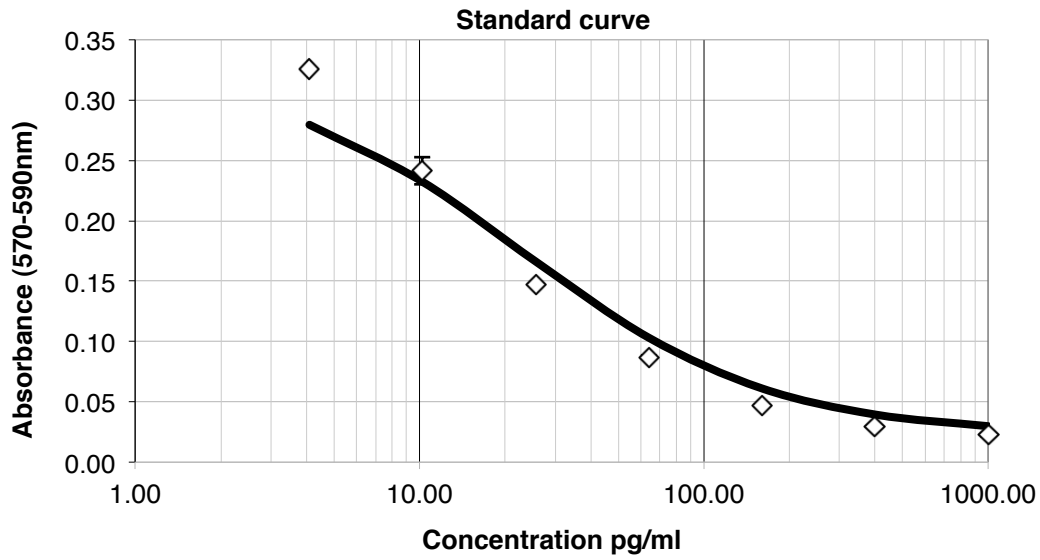

**Fig. 16.** The standard graph curve with the different standard sample in the Vasopressin-Arg ELISA kit. The dots are the value of the standard sample.

### 3.6. Scoring:

The animal label and number were covered during the test to avoid any biasing. During the test animals were used randomly to avoid any preference.

**Chapter 1**

**Social deficits and ablated aggressive behavior in GAD67-haplodeficient male mice.**

#### **4.1. Introduction**

GABA has been associated with a number of psychiatric disorders like autism, bipolar disorder, depression and schizophrenia (Coghlan et al., 2012; Guidotti et al., 2005; Gonzalez-Burgos et al., 2011). Several studies have tried to understand their role in physiological processes and disorders onset. Intraneuronal GABA is known to tightly regulate GAD. Thus suggesting GAD to be an ideal marker to monitor GABAergic function during physiological regulation in the CNS (Hagihara and Ohki, 2013; Yip et al., 2007). GAD in nature exists as two isoform GAD65 and GAD67. Both isoforms are distinct in their function and distribution. GAD67 has been associated with the long-term regulation of GABA levels compared to GAD65 (Martin et al., 1991; Martin and Rimvall, 1993; Soghomonian and Martin, 1998).

Both GAD isoforms have been associated with a variety of psychiatric and developmental disorders. Disorders like autism, anxiety and depression have been associated with GAD65 dysfunction (Guidotti et al., 2000; Yip et al., 2007) and GAD67 expression has been associated with autism, bipolar disorder and schizophrenia (Thompson et al., 2009). Reduction of GAD67 mRNA and protein expression has been consistently observed in the prefrontal cortex and hippocampus of patients with bipolar disorder and schizophrenia (Guidotti et al., 2000; Hashimoto et al., 2003; Heckers et al., 2002). Autistic patients have shown reduction of GAD67 mRNA by 40% in the Purkinje cells (Yip et al., 2007). Polymorphisms in the promoter region of the GAD67 gene have been associated with autism, bipolar disorder and schizophrenia (Addington et al., 2005; Akbarian and Huang, 2006; Straub et al., 2007). Schizophrenic patients show reduction in GAD67 expression with GAD67 promoter methylation and an increase in DNA methyltransferase expression in the interneurons (Huang and Akbarian, 2007; Veldic et al., 2005). Ablation of the GAD67 expression and GAD67 promoter methylation induced by S-methionine caused a schizophrenia-like phenotype in rodents (Dong et al., 2005; Tremolizzo et al., 2002). The epigenetically induced changes are reversible through the administration of valproic acid, a histone deacetylation inhibitor and responsiveness to some antipsychotics highlights the potential of GAD67 as an entry point for the treatment of these disorders (Dong et al., 2008). The causal role of GAD67 in the development of the neuropsychiatric symptoms is still unknown.

Availability of transgenic animals for both isoforms had made it feasible to investigate their specific role in behavior and brain (Asada et al., 1996, 1997; Tamamaki et al., 2003). GAD65 null mutant mice have shown increased anxiety related phenotype with altered fear conditioned behavior and increased vulnerability to seizure but no distinct change in the brain GABA level (Bergado-Acosta et al., 2008; Sangha et al., 2009; Stork et al., 2000). On the contrast, GAD67 ablation prepared by a knock-in mutation of the GFP (green fluorescence protein) insert in the starting codon, die shortly postnatal by ischemia due to cleft palate formation (Asada et al., 1997; Tamamaki et al., 2003). Though GAD67<sup>+/-</sup> mice are viable and show no discernable morphological alteration, but display an overall 40 % reduction of GAD67 expression and a 16 % reduction of GABA levels in young adult brain (Tamamaki et al., 2003; Wang et al., 2009). These GAD67<sup>+/-</sup> mice are widely used to investigate the effects of GAD67 deficits in various psychological disorders. Studies with GAD67<sup>+/-</sup> mice displayed an increased vulnerability to maternal and fetal stress (Uchida et al., 2011), which have been identified as disposition factors for schizophrenia (Markham and Koenig, 2011).

Social phobia has been one of the key features in most of the psychiatric disorders (Baez et al., 2013; Couture et al., 2006; Kane et al., 2012; Schultz, 2005) associated with GABAergic dysfunction. Benzodiazepines are known to stimulate GABAergic signaling and modulate social interaction even in healthy humans in a dosage dependent manner (Lane et al., 2009). Disruption of GABAergic interneurons in mice during the early postnatal period results in social deficits (Levitt, 2005) and pharmacological modulation of GABA(A) receptor with imidazenil rescues social deficits caused by pharmacologically induced methylation of the GAD67 promoter and reduced GAD67 expression (Tremolizzo et al., 2005). GABA has been known to play an important role in aggressive behavior in humans as well as in rodents (Miczek et al., 2003; Yanowitch and Coccaro, 2011). Studies have shown GABAergic neurons in the amygdala to tightly regulate the incoming sensory pheromonal input and corresponding output and thus processing the vomeronasal system (Pereno et al., 2011). Hence suggesting there is a plausible association of GABA in the regulation of the overall social behavior both in humans and rodents.

Therefore, in this study I used GAD67<sup>+/-</sup> male mice to investigate the putative role of GAD67 in social behavior (social interaction, pheromone assessment and aggression) modulation and thus further validating the role of GAD67 and GABA in social behavior.



#### 4.2. Experiment design:

**Table 6.1.** Tabulated the different methods I used to address the role of GAD67 in social behavior modulation. Detail description of methods can be referred from methods section (page 24-59).

| Test                    | Sub test                 | Test type  |
|-------------------------|--------------------------|--|
| <b>Behavioral tests</b> | Social interaction       | One partner interaction (N=8 GAD67 <sup>+/-</sup> ; N=9 GAD67 <sup>+/+</sup> mice).              |
|                         |                          | Male (versus) vs. female interaction (N=9 GAD67 <sup>+/-</sup> ; N=8 GAD67 <sup>+/+</sup> mice). |
|                         | Pheromone identification | Social vs. non social odor (N=8 GAD67 <sup>+/-</sup> ; N=8 GAD67 <sup>+/+</sup> mice)            |
|                         |                          | Male vs. female odor (N=13 GAD67 <sup>+/-</sup> ; N=10 GAD67 <sup>+/+</sup> mice).               |
|                         | Odor sensitivity test    | Non social odor (N=13 GAD67 <sup>+/-</sup> ; N=10 GAD67 <sup>+/+</sup> mice).                    |
|                         |                          | Social pheromone odor (N=13 GAD67 <sup>+/-</sup> ; N=10 GAD67 <sup>+/+</sup> mice).              |
|                         | Aggression               | Resident intruder test (N=8 GAD67 <sup>+/-</sup> ; N=10 GAD67 <sup>+/+</sup> mice).              |
|                         | Circadian activity       | Home cage activity (N=13 GAD67 <sup>+/-</sup> ; N=10 GAD67 <sup>+/+</sup> mice).                 |

| Test                          | Sub test   | Test type  |
|-------------------------------|--|--|
| <b>Behavioral tests</b>       | Innate behavior  | Nest building<br>(N=8 GAD67 <sup>+/-</sup> ;<br>N=11 GAD67 <sup>+/+</sup> mice)  |
|                               |  | Pheromone urine marking test<br>(N=9 GAD67 <sup>+/-</sup> ; N=9<br>GAD67 <sup>+/+</sup> mice).   |
|                               | Anxiety-behavior   | Open field test<br>(N=10 GAD67 <sup>+/-</sup> ; N=10<br>GAD67 <sup>+/+</sup> mice).  |
|                               |  | Light and dark test<br>(N=8 GAD67 <sup>+/-</sup> ; N=8<br>GAD67 <sup>+/+</sup> mice).  |
| <b>Hormone quantification</b> | Blood serum test   | Testosterone test<br>(N=6 GAD67 <sup>+/-</sup> ; N=6<br>GAD67 <sup>+/+</sup> mice).  |
|                               |  | Vasopressin test<br>(N=6 GAD67 <sup>+/-</sup> ; N=6<br>GAD67 <sup>+/+</sup> mice).   |
| <b>Immunohistochemistry</b>   | Quantification of c-Fos activation in different regions post social stimuli exposure | c-Fos quantification in Olfactory bulb (AOB: Accessory olfactory bulb, GL: Glomeruli cells, GC: Granular cells), forebrain (LSD: Lateral septum dorsal, BNsT: Bed nucleus of the stria terminalis, MPOA: Medial preoptic area) and Amygdala (MeA: Medial amygdala, CoA: Cortico-medial amygdala) (N=6 GAD67 <sup>+/-</sup> ; N=6 GAD67 <sup>+/+</sup> mice). |

All animals used during the test were naïve. Except the mice used for anxiety measure were first exposed to open field paradigm. After 7 days they were used to quantify anxiety measure in light-dark avoidance test.

**Statistical analysis:**

Statistical analysis was done with Student's t test or Mann-Whitney U-test for pairwise comparison of the genotypes. Repeated measures analysis of variance (ANOVA) and Bonferroni's *post hoc* tests were done as per requirement.

### 4.3. Result

#### 4.3.1. Reduced social affiliation in GAD67<sup>+/-</sup> mice

Social behavior deficit has been a hallmark for most of the psychiatric disorders associated with GAD67 reduction. In this test I tried to understand the function of GAD67 in social interaction.

The test contained a series of measures to evaluate social behavior between the male-male and male-female mice. When GAD67<sup>+/-</sup> mice were tested against an unfamiliar male mouse versus an empty tube, the test mice avoided the social interaction and exhibited a reduced time for exploring the male mouse (contact time index:  $-25.7 \pm 20.23$  (mean $\pm$ SEM), i.e. preferring the empty tube). In contrast, GAD67<sup>+/+</sup> mice strongly explored the male interaction partner (contact time index:  $38.6 \pm 19.7$ ; genotype comparison: Student's unpaired t test,  $t(14)=5.1$ ,  $p < 0.0001$ ; Fig. 17. A).

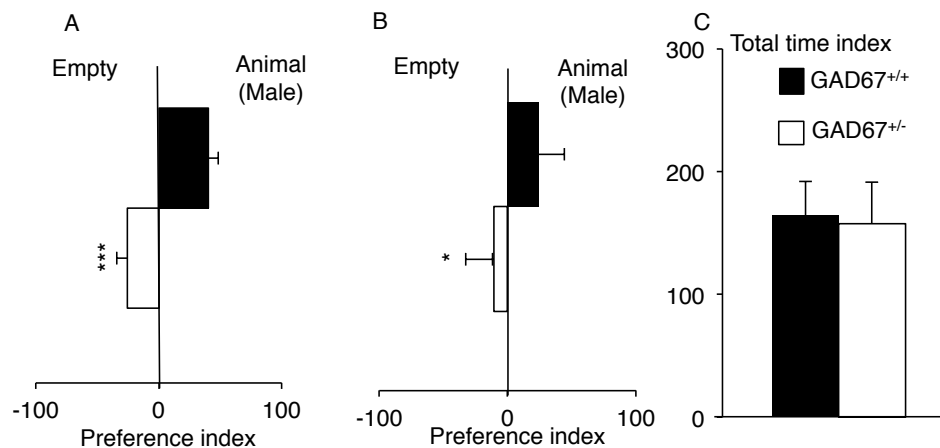
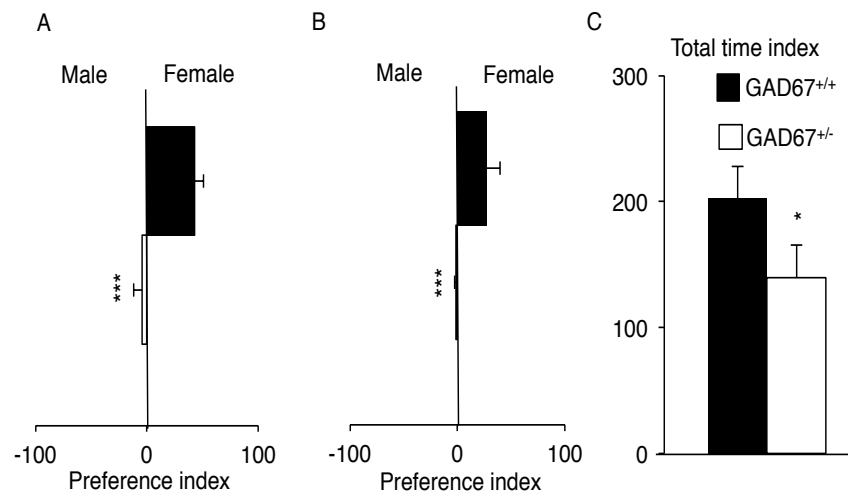

**Fig. 17.** Preference index in social interaction paradigm: GAD67<sup>+/-</sup> mice showed a reduction in preference for the interaction partner (male mouse) in contact time index (A). The contact number index showed a similar reduction in preference for the interaction partner by GAD67<sup>+/-</sup> mice (B). The total time index remained unaffected between the genotypes (C). All values are mean $\pm$ SEM: \*\*\* $p < 0.001$ , \*  $p < 0.05$ .

A similar behavior was observed for the number of the contacts made by the test mice (contact number index:  $-10.6 \pm 22.2$  vs.  $24.3 \pm 19.9$  in GAD67<sup>+/+</sup>;  $t(14)=2.9$ ,  $p < 0.01$ ; Fig. 17. B). Automated measurements of the exploration time in either of the compartments

showed a similar trend with  $GAD67^{+/-}$  mice displayed less preference (zone time index:  $-4.5 \pm 17.4$ ), whereas  $GAD67^{+/+}$  mice showed higher preference (zone time index:  $10.8 \pm 11.6$ ;  $t(14)=2.0$ ,  $p=0.06$ ) for the interaction male partner compartment. Though this measure did not reach significant level.

No change in the total time between the genotype for either of the tubes was observed (total time:  $157.6 \pm 34.0$  s in  $GAD67^{+/-}$  vs.  $170.1.1 \pm 25.5$  in  $GAD67^{+/+}$  mice;  $t(14)=0.2$ , n.s. (non significant); Fig. 17. C).



**Fig. 18.** Preference index with male versus female in social paradigm: The test data showed a reduction in contact time index (A) and contact number index (B) for female preference by  $GAD67^{+/-}$  mice. There was a significant reduction in the total time index observed in the male vs. female social paradigm with  $GAD67^{+/-}$  mice (C). All values are mean $\pm$ SEM: \*\*\* $p < 0.001$ , \*  $p < 0.05$ .

The second experiment was carried out to test the preference response of the  $GAD67^{+/-}$  male mice between an unfamiliar male and a female as an interaction partner.  $GAD67^{+/+}$  mice showed the expected preference for the female interaction partner with a significant increase in the number of contacts (contact number index  $27.1 \pm 12.7$ ), time of contact (contact time index  $43.0 \pm 18.2$ ) and an increase preference for the zone (zone time index:  $20.6 \pm 12.3$ ) containing the female partner. In contrast  $GAD67^{+/-}$  mice showed declined preference for the female partner compared to  $GAD67^{+/+}$  littermates (contact time index  $-4.3 \pm 26.6$ ;  $t(14)=3.1$ ,  $p < 0.01$ ; contact number index  $-1.7 \pm 17.4$ ;  $t(14)=3.5$ ,  $p < 0.005$ ; zone time index  $-62.0 \pm 16.5$ ;  $t(14)=6.9$ ,  $p < 0.0001$ ; Fig. 18. A, B). There was a significant reduction in the total time spent by the  $GAD67^{+/-}$  mice exploring the mice compared to

GAD67<sup>+/+</sup> (total time index 151.3±42.3 in GAD67<sup>+/-</sup> vs. 202.6±25.4 in GAD67<sup>+/+</sup> t(14)=2.5, p<0.05; Fig. 18 .C).

#### 4.3.2. Lack of social odor preference in GAD67<sup>+/-</sup> mice.

Social interaction has been linked to different olfactory cues especially social cues (Ryan et al., 2008). Deficits in the olfactory association have been associated with negative symptoms of schizophrenia in males (Litwack, 2010). Therefore, to investigate the association of GAD67 with social perception, GAD67<sup>+/-</sup> male mice were allowed to explore samples of social odor (male and female soiled bedding) as well as, non social odor (rose essence) as control.

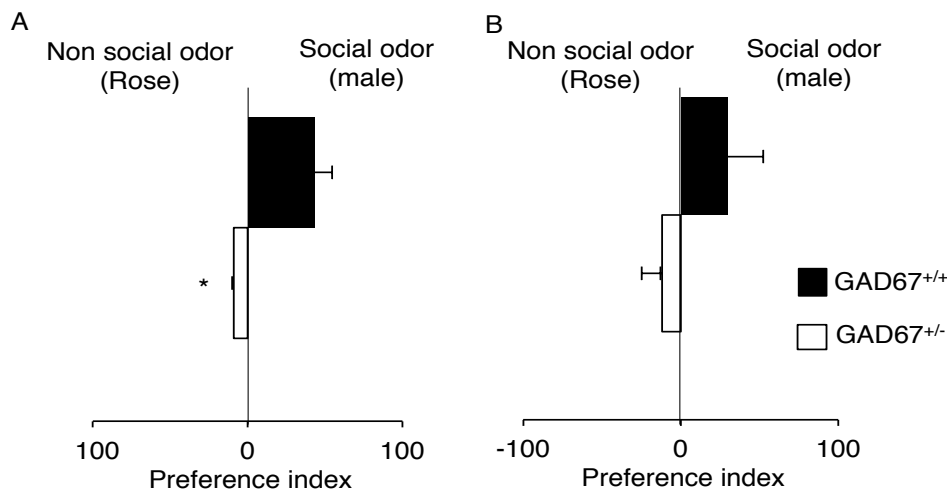

**Fig. 19.** Preference index measured in olfactory test between social (male bedding) and non social odor. GAD67<sup>+/-</sup> mice showed reduced preference for social odor (male bedding) both in contact time index (A) and contact number index compared to GAD67<sup>+/+</sup> mice. All values are mean±SEM: \* p < 0.05.

The first test consisted of a choice between social versus non social odor i.e., male bedding and rose essence. GAD67<sup>+/-</sup> male mice showed a reduction in the preference for the social odor (male bedding) (contact time index 9.1±11.4; contact number index 11.8±13.0; zone entry index 14.9±4.4) compared to their GAD67<sup>+/+</sup> littermates (contact time index 43.3±27.2; t(14)=2.9, p<0.05; contact number index 29.8±22.6; t(14)=2.5, p<0.05; Fig. 19. A, B; zone entry index 20.4±12.7; t(14)=1.2, n.s.).

A similar change in the preference was observed when female soiled bedding was offered as the social odor along with non social odor (rose essence),  $GAD67^{+/-}$  mice showing significantly less exploration of the social odor compared to their  $GAD67^{+/+}$  littermates (contact time index:  $-22.2 \pm 8.1$  in  $GAD67^{+/-}$  vs.  $7.6 \pm 20.2$  in  $GAD67^{+/+}$ ;  $t(14)=2.9$ ,  $p < 0.05$ ; contact number index:  $-4.5 \pm 8.6$  in  $GAD67^{+/-}$  vs.  $8.1 \pm 9.3$  in  $GAD67^{+/+}$ ;  $t(14)=2.1$ ,  $p < 0.05$ ; Fig. 20. A, B; zone entry index:  $2.3 \pm 7.6$  in  $GAD67^{+/-}$  vs.  $7.9 \pm 8.8$  in  $GAD67^{+/+}$ ;  $t(14)=0.7$ , n.s.).

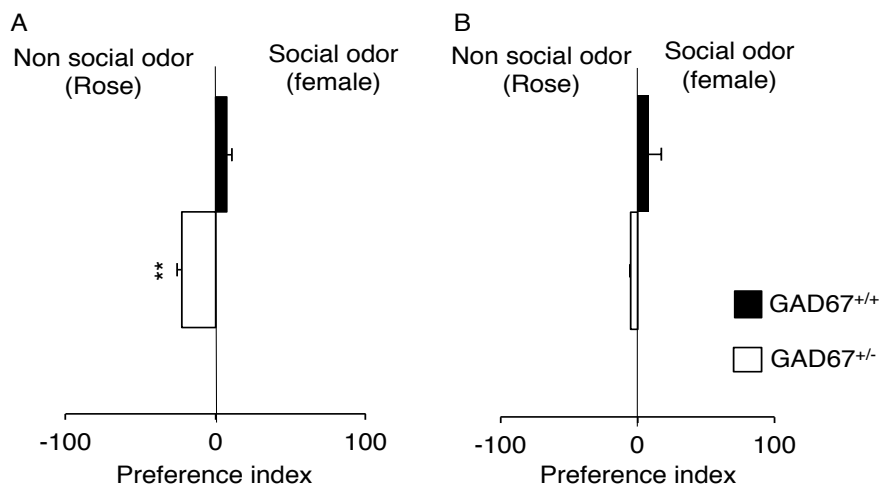

**Fig. 20.** Preference index values for the non social versus social (female) odor:  $GAD67^{+/-}$  showed a reduction in preference for social (female) odor both in contact time index (A) and in contact number index (B). All values are mean $\pm$ SEM: \*\* $p < 0.01$ .

The final test was to validate the preference of the  $GAD67^{+/-}$  and  $GAD67^{+/+}$  test mice between male and female soiled bedding. Strikingly,  $GAD67^{+/-}$  mice showed reduction in the preference for the female soiled bedding (contact time index:  $-17.6 \pm 9.7$ ; contact number index:  $-6.5 \pm 12.3$ ; zone entry index:  $-6.3 \pm 5.5$ ), in contrast to the  $GAD67^{+/+}$  littermates which showed a preference for the female bedding (contact time index:  $4.5 \pm 20.3$ ;  $t(13)=2.3$ ,  $p < 0.05$ ; contact number index:  $4.1 \pm 13.9$ ;  $t(13)=1.3$ , n.s.; zone entry index:  $6.9 \pm 10.0$ ;  $t(13)=2.4$ ,  $p < 0.05$ ; Fig. 21. A, B).

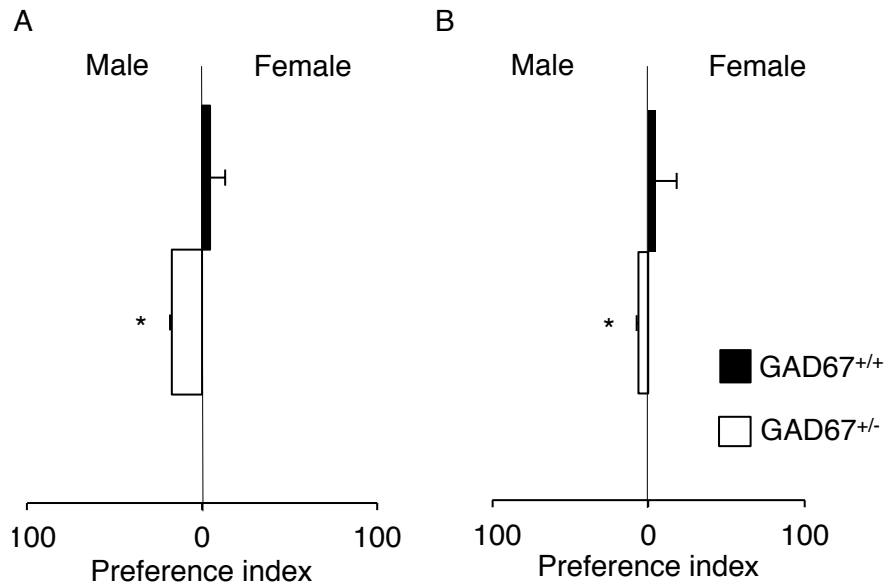
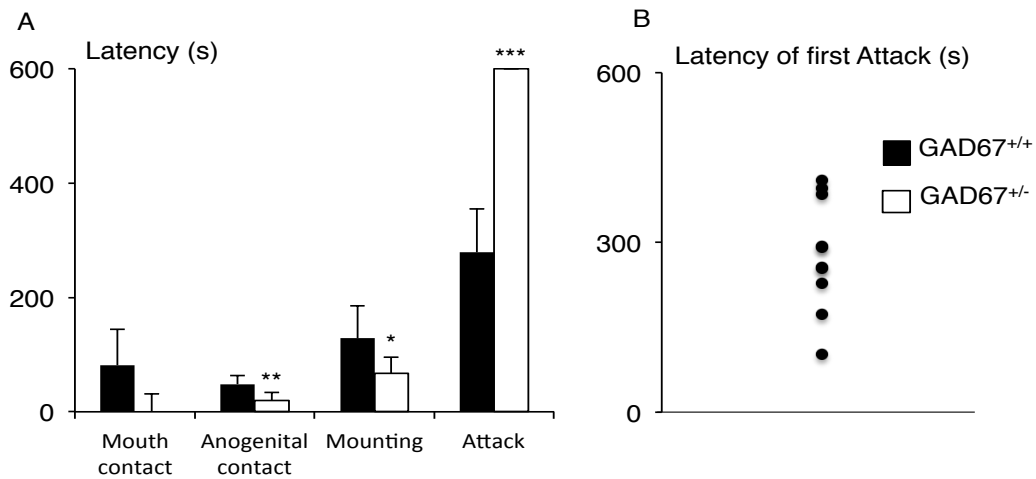

**Fig. 21.** Preference index between male and female odor: A reduction in the contact time index for female odor preference observed in GAD67<sup>+/-</sup> mice (A). The contact number index was also disrupted in GAD67<sup>+/-</sup> mice for the female preference (B). All values are mean±SEM: \* p < 0.05.

#### 4.3.3. Reduced aggressive behavior of GAD67<sup>+/-</sup> mice.

Pheromone dysfunction has been known to influence aggressive behavior especially in rodents (Liedtke et al., 2007; Punta et al., 2002). Here I investigated if the disturbed social pheromone assessment influences the aggressive behavior. In the resident-intruder aggression paradigm, the resident mice displayed different pattern of social and aggressive behaviors: frontal and anogenital sniffing, mounting, attacks on encounter with an unfamiliar male intruder (Wersinger et al., 2002). There was an increase in the latency for the first mouth contact by GAD67<sup>+/-</sup> mice but the values failed to reach significance ( $38.0 \pm 31.0$  s vs.  $81.6 \pm 63$  s in GAD67<sup>+/+</sup>;  $t(16)=1.7$ , n.s.). GAD67<sup>+/-</sup> mice showed a significant reduction in the latency both for anogenital sniffing ( $19.6 \pm 14.1$  s vs.  $48.5 \pm 14.8$  s in GAD67<sup>+/+</sup>;  $t(16)=3.7$ ,  $p < 0.005$ ) and for mounting ( $67.1 \pm 28.3$  s vs.  $128.9 \pm 56.7$  s in GAD67<sup>+/+</sup>;  $t(16)=2.2$ ,  $p < 0.05$ ; Fig. 22. A)

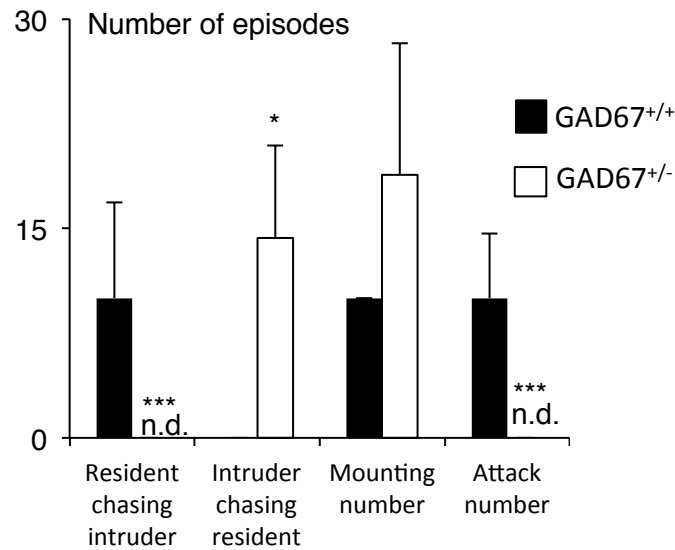



**Fig. 22.** Resident intruder aggression test: The data show latency (s:seconds) to initiate an aggressive behavior by the resident mice towards the intruder during the aggression test (A). The graph show the latency to make the first attack by individual resident mice towards the intruder (B). All values are mean $\pm$ SEM: \*\*\* $p < 0.001$ , \*\* $p < 0.01$ , \*  $p < 0.05$ .

Aggressive behavior was mainly recorded in the littermates and mostly within the initial 5 min (Fig. 22. B) of the experiment (latency for first attack: 279.1 $\pm$ 76.0 s; number of attacks: 3.0 $\pm$ 1.2 GAD67<sup>+/+</sup>)(Fig 22.A, 23). Whereas GAD67<sup>+/-</sup> resident mice failed to display any attack, towards the intruder during the whole test session of 10 minutes (Mann Whitney U-test,  $p < 0.001$ ).

The chasing of the intruder by the resident mice was observed only in the GAD67<sup>+/+</sup> (10.0 $\pm$ 6.9;  $p < 0.001$ ) mice. Surprisingly, GAD67<sup>+/-</sup> mice failed in attempts to display attack behavior towards the resident mice, on the other hand they chased (12.5 $\pm$ 5.2;  $p < 0.02$ ) or attacked (number of intruder attacks: 10.0 $\pm$ 4.6;  $p = 0.06$  compared to GAD67<sup>+/+</sup> residents) by the intruder mice (Fig. 23.).



**Fig. 23.** Resident intruder aggression test (n: numbers): The number of episodes of different behaviors measured during the resident-intruder test. All values are mean±SEM: \*\*\* $p < 0.001$ , \*  $p < 0.05$ .

#### 4.3.4. Unaltered nest building of GAD67<sup>+/-</sup> mice.

Olfactory function has been associated with nest building. Studies have shown removal of the olfactory bulb resulted in impairment in nest building (Uchida, 2005; Zarrow et al., 1971). Therefore to validate if the impaired social and olfactory deficit induce an effect on the nest building in the GAD67<sup>+/-</sup> mice, I measure the nest building behavior of the two genotypes. The data showed an increase in the nesting material collected over the test period of 24 hours but no effect between the genotype was observed (repeated measures ANOVA time  $F(1,16)=67.5$ ;  $p < 0.001$  and time\*genotype  $F(1,16)=0.0$ , n.s). However, both the genotype showed same complexity of nest building within 24 hours (At 24 h:  $3.2 \pm 0.7$  type in GAD67<sup>+/-</sup> and  $3.2 \pm 0.9$  type in GAD67<sup>+/+</sup>; Student's t-test:  $t(17)=0.2$ , n.s.; Fig. 24.). Thus, suggesting no evidence for quantitative difference between the genotypes.

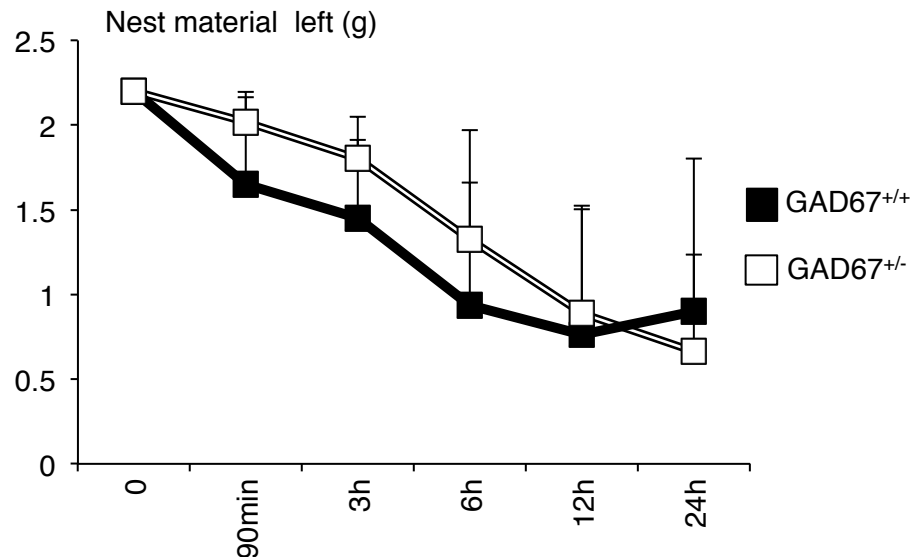

**Fig. 24.** Nest building behavior measure: There was no difference observed in the nest building material used over time span of 24 h between the two genotype. All values are mean $\pm$ SEM.

#### 4.3.5. Unaltered urine marking in the GAD67<sup>+/-</sup> mice.

Environmental stresses are known to effect animal's territorial marking behavior (Lumley et al., 1999). Though it is plausible GAD67<sup>+/-</sup> male mice might have been subjected to chronic stress by their littermates, during group housing prior to adulthood maturation. Therefore, to investigate do GAD67<sup>+/-</sup> mice have intact social hierarchy establishment. There was no significant difference between GAD67<sup>+/-</sup> (88.9 $\pm$ 133.3 n) and GAD67<sup>+/+</sup> mice urine markings (159 $\pm$ 195.7 n;  $t(17)=1.7$ , n.s; Fig. 25. A, B).

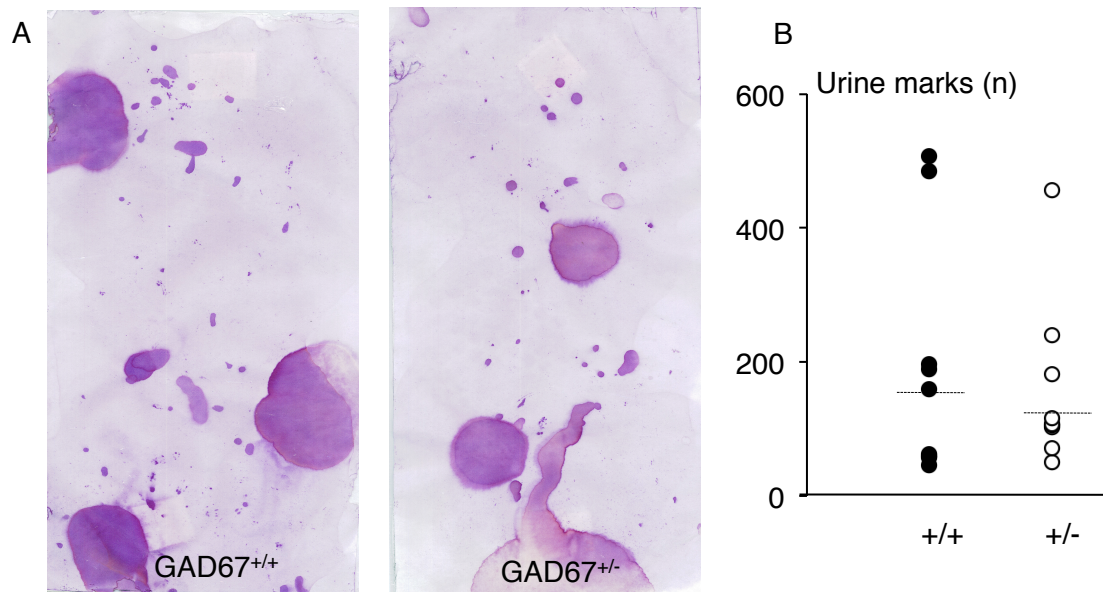

**Fig. 25.** Urine marking test: The filter paper shows the urine mark pattern made by the mice during the test (A). The graph display the number of urine marks (n) made by individual mouse from the two genotypes (B). The dotted line represents the mean in both groups.

#### 4.3.6. Delayed diurnal rhythm of GAD67<sup>+/-</sup> mice.

GABA has been known to regulate the circadian rhythm in the suprachiasmatic nucleus and other associated regions (Liu and Reppert, 2000; Mody et al., 1994). A recent study by Bergado-Acosta et al., (2014) showed altered circadian activation and its interference in fear conditioning in GAD65 transgenic mice. To investigate if GAD67 affects the circadian activity, I measured the spontaneous activity of GAD67<sup>+/-</sup> mice in their home cage over three consecutive days. Analysis of home cage locomotor activity revealed a 2 h shift in the activity pattern of GAD67<sup>+/-</sup> mice (Fig. 26.). While GAD67<sup>+/+</sup> littermates showed a change from predominantly inactive to active at ZT23 (Zeitgeber<sup>10</sup>) (one hour preceding lights off) and from active to inactive ZT11 (one hour preceding lights on), such changes were observed in GAD67<sup>+/-</sup> at ZT1 and ZT13, respectively. Thus, a significant difference of activity between genotypes was evident on ZT23 (7.5±5.8 % in GAD67<sup>+/-</sup> vs. 52.2±9.6 % in

<sup>10</sup> It is an external cue that entrains or synchronizes an organism's biological rhythms to the light/dark cycle.

GAD67<sup>+/+</sup>;  $t(21)=4.9$ ,  $p<0.001$ ) and ZT24 ( $8.5\pm 5.9\%$  vs.  $41.7\pm 21.1\%$ ;  $t(21)=4.7$ ,  $p<0.001$ ), as well as on ZT11 ( $60.0\pm 10.1\%$  in GAD67<sup>+/-</sup> vs.  $13.1\pm 6.6\%$  in GAD67<sup>+/+</sup>;  $t(21)=9.1$ ,  $p<0.001$ ) and ZT12 ( $63.7\pm 16.9\%$  vs.  $10.0\pm 7.9\%$ ;  $t(21)=6.9$ ,  $p<0.001$ ). The average locomotor activity during their respective active (ZT23-10 in GAD67<sup>+/+</sup> and ZT1-12 in GAD67<sup>+/-</sup>) and corresponding resting phases, however, was no difference between genotypes (activity:  $47.8\pm 5.9\%$  in GAD67<sup>+/-</sup> vs.  $44.9\pm 4.5\%$  in GAD67<sup>+/+</sup>;  $t(18)=0.0$ , n.s. and resting:  $8.7\pm 1.9\%$  in GAD67<sup>+/-</sup> vs.  $8.4\pm 2.0\%$  in GAD67<sup>+/+</sup>;  $t(13)=0.4$ , n.s.; Fig. 26).

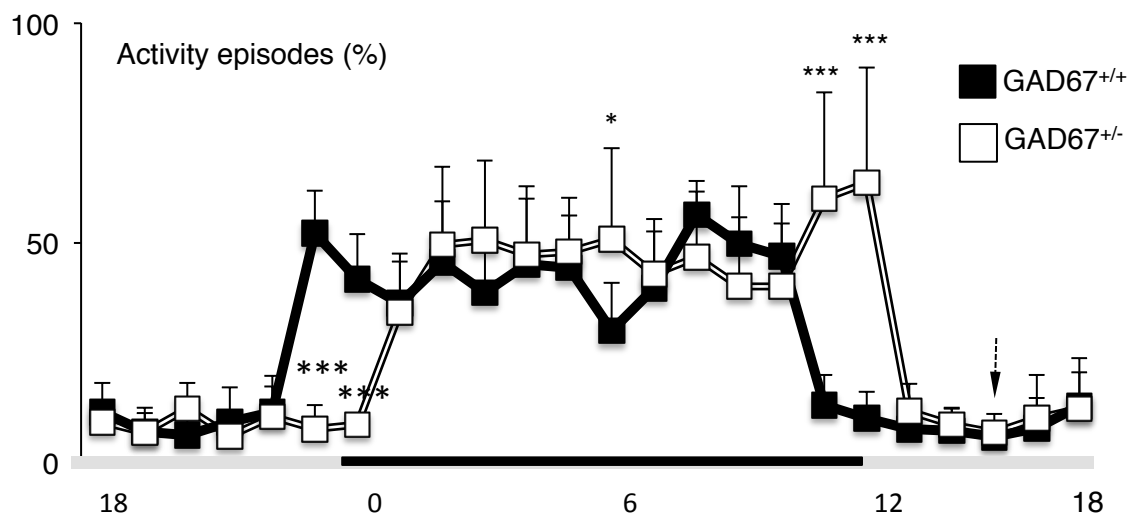

**Fig. 26. Home cage activity.** 2 h delay during the two phase shifts was recorded with home cage activity measurements in GAD67<sup>+/-</sup> mice compared to GAD67<sup>+/+</sup> littermates. All values are mean $\pm$ SEM: \*\*\* $p < 0.001$ , \*  $p < 0.05$ .

#### 4.3.7. Exploratory and anxiety-like behavior of GAD67<sup>+/-</sup> mice.

Open field measurements revealed no significant difference between the genotypes in the total distance travelled ( $88.0\pm 5.9$  m GAD67<sup>+/-</sup> and  $80.3\pm 7.1.0$  m GAD67<sup>+/+</sup>,  $t(17)=2.1$ , n.s.) or entries in the center area ( $20.2\pm 2.2\%$  GAD67<sup>+/-</sup> and  $19.7\pm 2.1\%$  GAD67<sup>+/+</sup>,  $t(17)=0.9$ ; n.s.; Fig. 27. A, B).

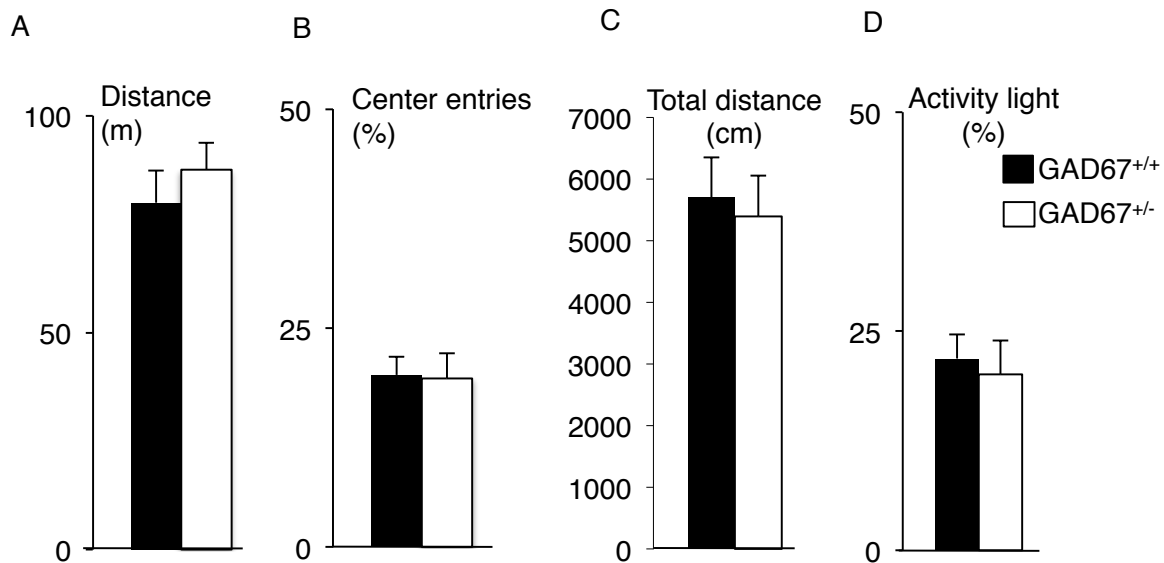
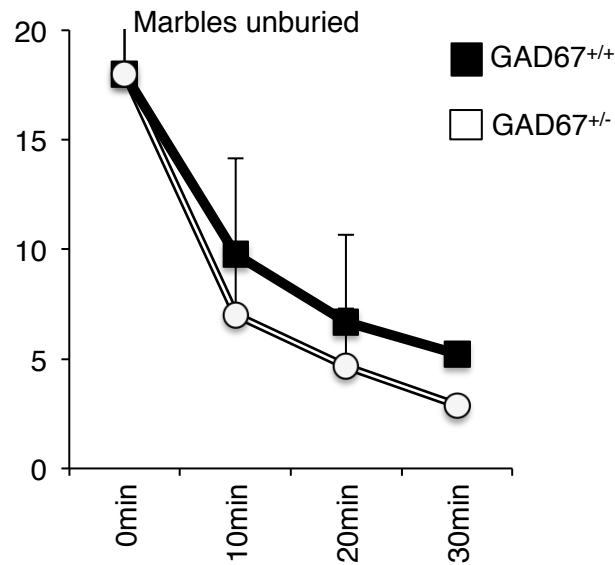

**Fig. 27.** Anxiety measurements in open field and light-dark avoidance test: Overall no change was observed between the genotypes in the total distance covered (A) and centre entries (%) (B) in the open field. No change observed in total distance covered (C) or total activity measure (%) (D) between the genotypes in the light compartment. All values are mean±SEM.

In light-dark avoidance test no change in the behavioral measurement was observed between the genotype with respect to the total distance (5395.9±665.6 cm in GAD67<sup>+/-</sup> vs. 5705.7±644.5 cm in GAD67<sup>+/+</sup>,  $t(14)=0.7$ , n.s.; Fig. 27. C), activity period (243.5±9.2 s in GAD67<sup>+/-</sup> vs. 237.2±7.9 s in GAD67<sup>+/+</sup>,  $t(14)=1.2$ , n.s.), or the relative exploration activity (21.9±2.7 % in GAD67<sup>+/-</sup> vs. 20.1±3.8 % in GAD67<sup>+/+</sup>,  $t(14)=0.9$ , n.s.; Fig. 27. D) in the light compartment.

#### 4.3.8. No change in marble burying test.

The marble burying test showed no marked difference between genotypes (repeated measures ANOVA for time  $F(1,32)=15.5$ ,  $p<0.001$  and for time\*genotype  $F(1,32)=0.1$ ; n.s.; Fig. 28.) (30 min: 2.8±2.8 n GAD67<sup>+/-</sup> vs. 5.2±4.0 n GAD67<sup>+/+</sup>;  $t(15)=1.1$ , n.s.).



**Fig. 28.** Marble burying test: The number of marbles left unburied were similar between the two genotypes. All values are mean±SEM.

#### 4.3.9. Increase odor sensitivity at higher concentration by GAD67<sup>+/-</sup> mice

To validate the olfactory sensitivity in the GAD67<sup>+/-</sup> mice and to assess if the mice can identify the odor at diluted concentrations. The test mice were exposed to series of orders in ascending order of concentration. GAD67<sup>+/-</sup> mice showed a reduced preference for assessing the rose odor at dilute factor of  $10^{-4}$  (rose odor: time index -  $13.02 \pm 21.2$  in GAD67<sup>+/-</sup> vs.  $23.9 \pm 17.2$  in GAD67<sup>+/+</sup>; Student's t-test,  $t(14)=3.4$ ,  $p < 0.01$ ; contact number index  $-4.1 \pm 15.1$  in GAD67<sup>+/-</sup> vs.  $17.3 \pm 13.1$  in GAD67<sup>+/+</sup>;  $t(14)=2.3$ ,  $p < 0.05$ ) and  $10^{-2}$  (time index  $-5.9 \pm 21.2$  in GAD67<sup>+/-</sup> vs.  $30.9 \pm 20.7$  in GAD67<sup>+/+</sup>;  $t(14)=2.6$ ,  $p < 0.05$ ; contact number index  $4.4 \pm 14.9$  in GAD67<sup>+/-</sup> vs.  $23.8 \pm 10.9$  in GAD67<sup>+/+</sup>;  $t(14)=2.4$ ,  $p < 0.05$ ). On the contrary the GAD67<sup>+/-</sup> mice showed increase preference at a higher concentration of  $10^{-1}$  in assessing the odour similar to the wild type littermates (time index:  $22.1 \pm 21.2$  in GAD67<sup>+/-</sup> vs.  $20.3 \pm 9.9$  in GAD67<sup>+/+</sup>; contact number index  $4.9 \pm 18.6$  in GAD67<sup>+/-</sup> vs.  $7.1 \pm 20.3$  in GAD67<sup>+/+</sup>; Fig. 29.).

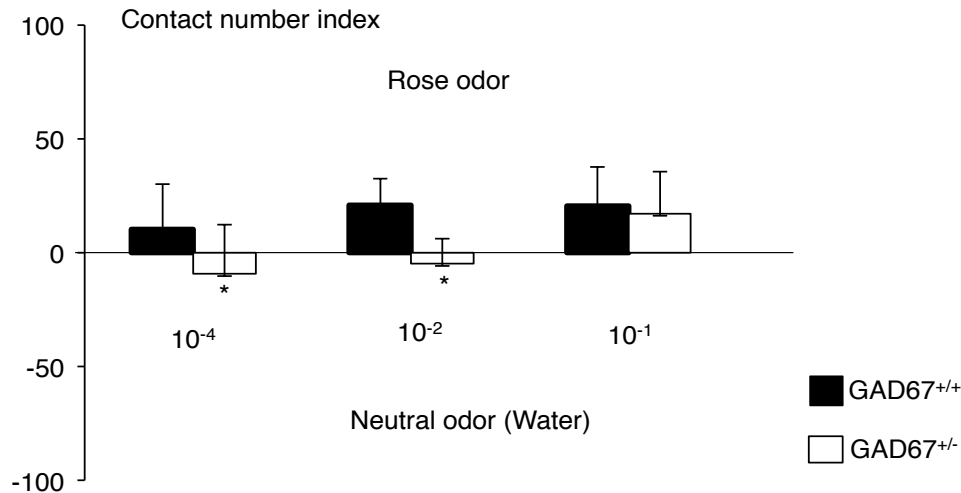

**Fig. 29.** The odor sensitive test with non-social odor (rose odor) offered at different dilutions: The GAD67<sup>+/-</sup> mice showed an overall impaired reduction towards non-social (rose) odor preference at lower dilution compared to the GAD67<sup>+/+</sup> mice. All values are mean±SEM: \*  $p < 0.05$ .

For further assessment of the olfactory sensitivity function female urine of different dilutions were offered to the test mice. Though urine is less efficient than soiled bedding or mouse interaction partner to induce exploratory preference a similar trend confirmed impaired olfactory function. GAD67<sup>+/-</sup> mice showed reduced preference towards the odor assessment at 10<sup>-2</sup>-fold (time index: 6.3±26.8 vs. 26.0±22.6 in GAD67<sup>+/+</sup>; contact index -9.4±21.7 vs. 10.4±19.7 in GAD67<sup>+/+</sup>) and significantly at 10-fold dilution (time index: 10.4±20.4 vs. 31.0±20.3 in GAD67<sup>+/+</sup>; contact index -4.9±11.1 vs. 20.7±11.9 in GAD67<sup>+/+</sup>,  $t(14)=3.5$ ,  $p<0.01$ ). Likewise at a higher concentration of the female pheromone GAD67<sup>+/-</sup> mice showed increase preference similar to the GAD67<sup>+/+</sup> mice time index: 35.3±18.9 vs. 39.7±30.6 in GAD67<sup>+/+</sup>; contact index 17.3±18.3 vs. 20.5±17.2 in GAD67<sup>+/+</sup>; Fig. 30).



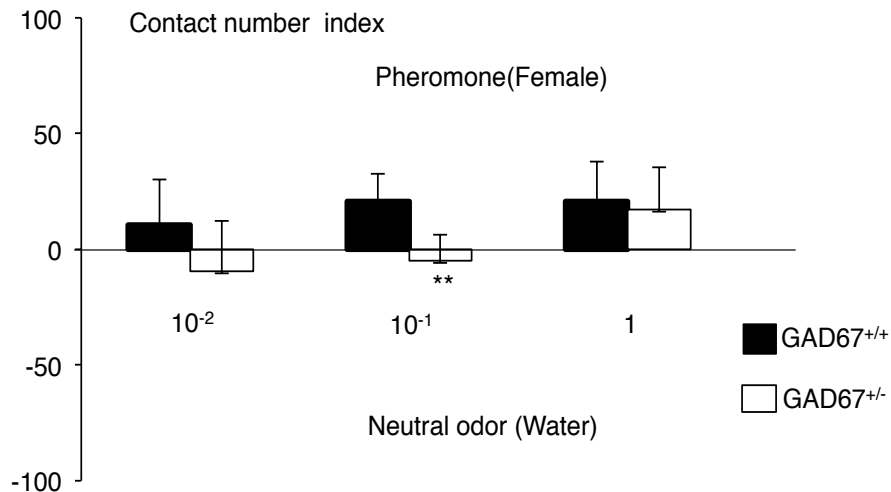

**Fig. 30.** The odor sensitive test measured with female pheromone (urine) at different dilutions: There was an overall impaired reduction for the female urine odor preference at lower dilution in GAD67<sup>+/-</sup> mice compared to GAD67<sup>+/+</sup> mice. All values are mean±SEM: \*\*p < 0.01.

#### 4.3.10. Altered c-Fos expression in the different subregions associated with social interaction.

To quantify if the impairment observed in the GAD67<sup>+/-</sup> mice are associated with deficits in activation of anatomical regions critical for processing of the input. Henceforth to investigate whether the activation of regions associated with the social interaction input was intact. I carried out c-Fos immunostaining in mice undergone social interaction test one hour prior to tissue protein fixation. Different regions involved with the social interaction were quantified to measure the neuronal activity (Fig. 31.).

The olfactory input is received and processed in the olfactory bulb. Therefore, layers such as accessory olfactory bulb (AOB), granular cell layer (GC) and glomeruli (GL) were quantified between the two genotypes (Table 6.2; Fig. 31). No significant change was observed with cell counting between the olfactory layers (Table 6.2; Fig. 31). The information from the olfactory bulb forms a direct input at the level of amygdala in medial amygdala (MeA). Cell counting showed a marked significant attenuation in the number of cells in medial amygdala and also in cortical amygdala (CoA) (Table 6.2; Fig. 31, 32). The information after processing at the medial amygdala is passed to the

bed nucleus of the stria terminalis (BNsT) and lateral septum dorsal (LSD) and medial preoptic area (MPOA). Surprisingly, a significant reduction in neuronal activation was observed in MeA, CoA, LSD, MPOA and BNsT regions in GAD67<sup>+/-</sup> mice compared to GAD67<sup>+/+</sup> mice (Fig. 31, 32).

**Table 6.2.** Table shows the c-Fos expression between the genotypes in different regions. Here I quantified the c-Fos cell number/area mm<sup>2</sup> along with their respective p value which I calculated with unpaired Student's t test:

| <b>Region</b> | <b>GAD67<sup>+/+</sup></b><br>(mean±SEM) | <b>GAD67<sup>+/-</sup></b><br>(mean±SEM) | <b>P value</b> |
|---------------|--|--|----------------|
| AOB           | 271±52.3                                 | 225±53.1                                 | 0.42           |
| GC            | 291.3±62.4                               | 306.7±102.7                              | 0.84           |
| GL            | 169.1±86.6                               | 139.1±42.3                               | 0.63           |
| MeA           | 124.2±27.6                               | 221.3±46.8                               | 0.0095; **     |
| CoA           | 114.5±36.9                               | 265.9±92.7                               | 0.023; *       |
| LSD           | 49.5±12.6                                | 136.5±61.6                               | 0.01; *        |
| BNsT          | 92.7±14.5                                | 236.8±53.9                               | 0.0004; ***    |
| MPOA          | 113.7±75.2                               | 264.0±97.5                               | 0.041; *       |

\*p<0.05; \*\* p<0.01; \*\*\*p<0.001

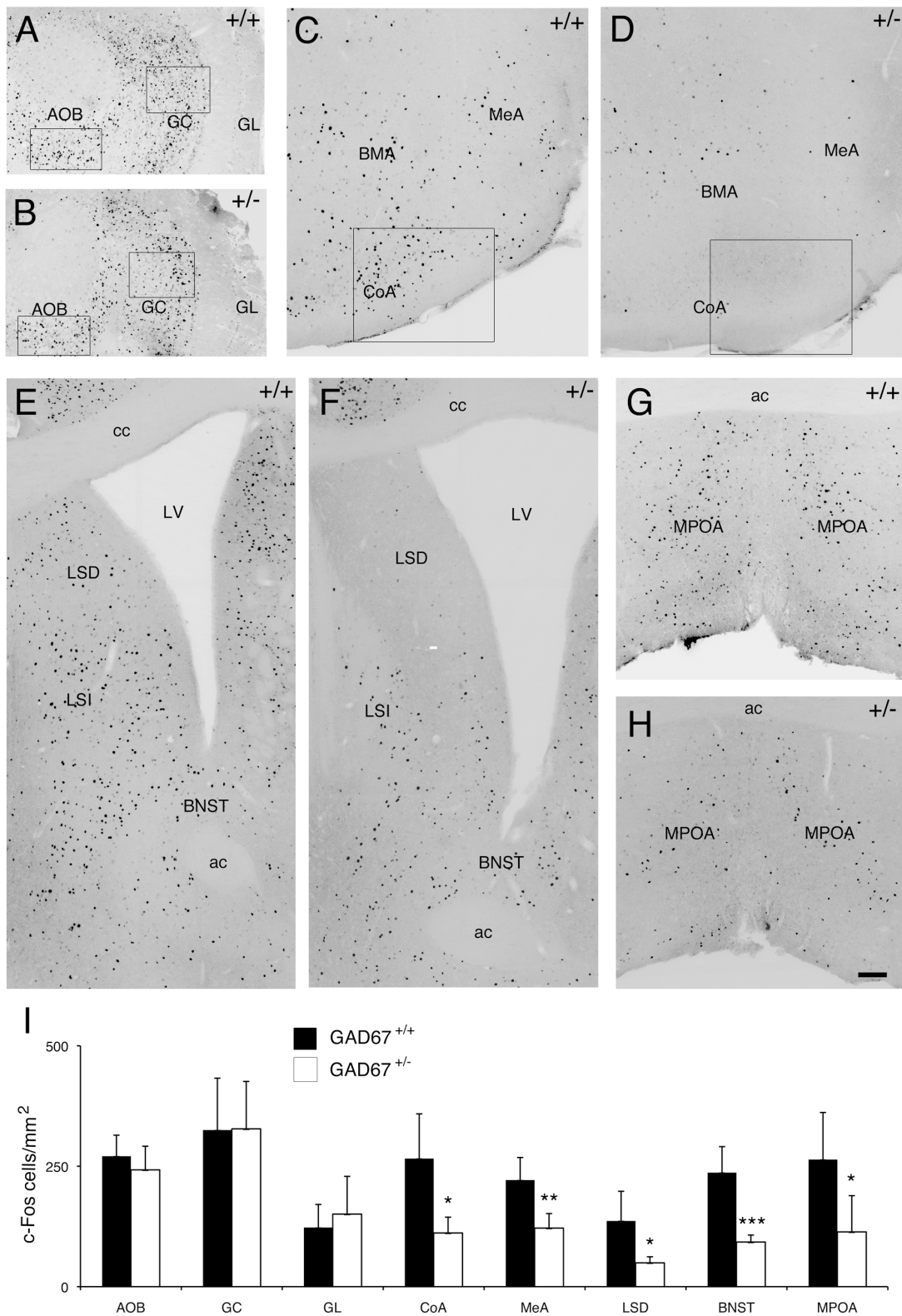

**Fig. 31.** Reduced c-Fos expression in  $GAD67$  haplodeficient mice after social encounter. c-Fos labeling was evaluated in coronal sections from  $GAD67^{+/+}$  (A,C,E,G) and  $GAD67^{+/-}$  (B,D,F,H) mice, as an indicator of neural activity 1h after social stimulation. Comparable staining intensity between genotypes was observed in

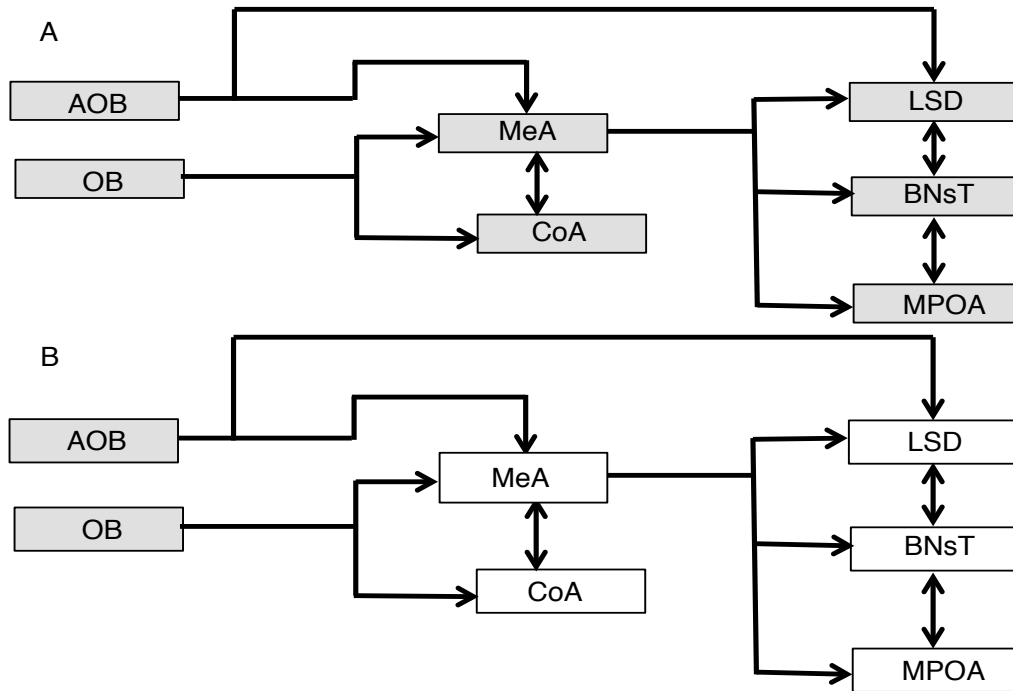

**Fig. 32.** Neuroanatomical areas analyzed for c-Fos expression after social encounter between the genotypes: this diagram represents the circuit associated with the input and processing of various brain regions associated with social interaction. The diagram represents the overall activation of different regions in  $GAD67^{+/+}$  (A) and  $GAD67^{+/-}$  (B) mice brain. The grey boxes indicate the activation is similar to the control  $GAD67^{+/+}$  mice. The white boxes indicate reduction in c-Fos activation on comparison to  $GAD67^{+/+}$  mice. Accessory olfactory bulb (AOB); main olfactory bulb (OB); the lateral septum dorsal (LSD); the bed nucleus of the stria terminalis (BNsT); the medial preoptic area (MPOA); the medial amygdala (MeA) and the cortical nucleus of the amygdala (CoA). Schematic illustrating the flow of olfactory information in rodent brain (Ferguson et al., 2001; Meredith, 1991)

#### 4.3.11. Normal testosterone and vasopressin concentrations in $GAD67^{+/-}$ mice

Vasopressin has been associated to modulate social behavior especially in male mice (Goodson and Bass, 2001).  $GAD67^{+/-}$  mice showed ablation in aggression and fail to display any aggressive behavior in the resident-aggression test. Testosterone is known to modulate aggression both in male and female rodents (Lisciott et al., 2006,

1985; Sandnabba et al., 1994). I carried out blood serum ELISA to validate the vasopressin and testosterone levels in the two genotypes.

The serum measurement showed no significant difference between the genotype in either testosterone ( $1.3 \pm 0.1$  ng/ml in  $GAD67^{+/-}$  vs.  $1.5 \pm 0.1$  ng/ml in  $GAD67^{+/+}$ ;  $t(9)=1.4$ , n.s.; Fig. 33. A) or vasopressin ( $56.82 \pm 6.9$  pg/ml in  $GAD67^{+/-}$  vs.  $68.22 \pm 10.1$  pg/ml in  $GAD67^{+/+}$ ;  $t(9)=1.0$ , n.s.; Fig. 33. B) levels.

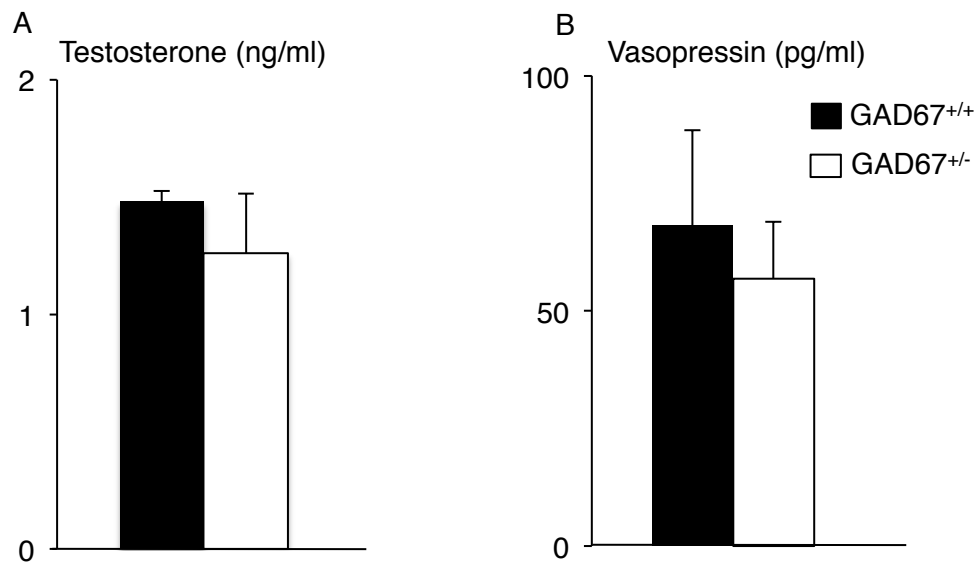

**Fig. 33.** Hormone measure in blood serum of the two genotypes: no change in testosterone (ng/mL) (A) or vasopressin levels between the genotypes (pg/mL) was observed (B). All values are mean $\pm$ SEM.

#### 4.4. Discussion

GAD67 has been associated with a number of psychiatric disorders especially schizophrenia, autism and bipolar disorder but limited information is known about GAD67 association with the onset of the symptoms. Social and olfactory deficit symptoms are associated with most of the psychiatric disorders reported with GAD67 reduction (Barnett et al., 1999; Malaspina et al., 2012). Studies have shown a correlation of the negative symptoms of schizophrenia with odor identification (Brewer et al., 1996; Corcoran et al., 2005; Geddes et al., 1991). Interestingly male are known to show a high prevalence for negative symptoms of schizophrenia than females (Choi et al., 2009). Studies have shown a role of gonadal hormone in the regulation of social behavior (Clipperton-Allen et al., 2012). Hence in my study I used male mice to address the role of GAD67 gene in modulation of social behavior.

GAD67 complete mutant mice die during birth due to the cleft palate formation, hence GAD67 haplodeficit mice are being widely used for studying GABA function and GAD67 mechanism (Bang and Commons, 2012; Tamamaki et al., 2003; Young and Sun, 2009). These mice display a normal brain development but they show 40% reduction of GAD67 and 16% reduction of GABA levels in young adult brain (Wang et al., 2009). Therefore, GAD67 haplodeficit mice are apt for the profiling of the GAD67 function at the phenotypic level. As discussed earlier GAD67 is associated with a number of neuropsychiatric disorders. Social interaction deficit is a hallmark for most of these disorders. Studies both in schizophrenia (Brewer et al., 2007) and autism are linked with pheromone or odor identification further linked to social impairment (Malaspina et al., 2003; 2012). In my study, I observed similar deficits in social preference and also in odor assessment by the GAD67<sup>+/-</sup> mice. Thus suggesting altered GAD67 expression in the GAD67 haplodeficient mice to mimic the social deficits observed in neuropsychiatric subjects.

During the social preference assessment GAD67<sup>+/-</sup> displayed disinclination towards interaction with conspecifics and showed predisposition towards the chamber devoid of an interaction partner. Animal model for psychiatric disorders have shown decline in social interaction especially with a female partner (Briellmaier et al., 2012). Similarly, in our social interaction paradigm when offered a choice between an unfamiliar male and

female partner,  $GAD67^{+/-}$  mice showed reduction in social interaction with female partner unlike the wild type littermates with a high preference for female interaction partner. Thus suggesting  $GAD67$  may have a plausible role in the mediation of the social interaction phenotype.

There is a strong correlation between social preference and sociability related behavior and pheromone stimuli (Silverman et al., 2010; Stowers and Marton, 2005). The pheromone assessment paradigm consisted of a social odor versus non social odor choice test.  $GAD67^{+/-}$  mice showed a disinclination for the social odor and an overall avoidance for the female soiled bedding. Thus suggesting an overall disturbance of their pheromone mediated behavioral response. The altered social interaction and odor preference by the  $GAD67^{+/-}$  mice suggested a possible deficit in the olfactory sensitivity.  $GAD67^{+/-}$  mice failed to associate the odor at the diluted concentration both for an odor that is a non social odor and also for female pheromone (female urine). Surprising in both the test  $GAD67^{+/-}$  mice showed an increase preference at a high concentration thus suggesting a possible disturbance in assessment of the odor and impaired odor sensitivity.

Social behavior is a spectrum of different behaviors, and aggression forms one aspect of it. Aggression is known to depend on a number of characteristics associated with the encountered animal and olfactory assessment of the opponent is one of them (Ginsburg and Allee, 1942, Guillot and Chapouthier 1996). Deficits in the olfactory measure observed in the  $GAD67^{+/-}$  mice could have implications on the aggression response as well. Additionally, pheromones do play a critical role both in social and aggressive behavior (Novotny et al., 1985). GABA(A) receptor modulation has been linked both to aggressive behavior and olfactory function (Guillot and Chapouthier 1996). Therefore I validated  $GAD67^{+/-}$  function in aggression by measuring it in a resident intruder aggression paradigm. Reduced latency towards social investigation in the secure environment of the home cage by the  $GAD67^{+/-}$  mice could suggest increased inspection to assess the encounter mice at different levels of identification and association. On the other hand  $GAD67^{+/-}$  mice failed to display any attack towards the intruder in the home cage. Disinclination to display aggressive behavior by the  $GAD67^{+/-}$  mice was followed by aggressive behavior towards them by the intruder often with chase and attack towards the resident mice. GABA has been associated with aggression and reduction in GABA has been associated with increased aggression especially in human subjects with

pathological state (Lieving et al., 2008). In my finding I observed a contrasting result with a reduction in aggressive behavior in reduced GAD67 state. Aggression paradigms using animal models assess only the quantitative aspect of the aggressive encounters, whereas human with pathological aggression do not fight in an obvious situation to fight but they display aggressive behavior in situation when it is least expected by a normal person. (Nelson and Trainor, 2007). The increased social interaction by the GAD67 haplodeficit mice could be due to the secure environment i.e., home cage territory of the mice. Though increased latency in GAD67<sup>+/-</sup> mice may suggest intact social interaction in secure environment but ablated aggression could result from impaired development of the social hierarchy. Thus aggression test validate the function of the GAD67 in response to territorial protection and hierarchy establishment.

Olfactory dysfunction and olfactory bulb removal hinders nest building (Uchida, 2005; Zarrow et al., 1971). Interestingly the nest building behavior remained unaltered between the genotypes. Anatomical networks mediating the different social behavioral parameters are closely linked. Medial amygdala has been the central processing unit in most of the social behavioral (Ferguson et al., 2001).

Social interaction is mediated through the interaction and processing of input by different regions mediating social behavior (Ferguson et al., 2001; Richter et al., 2005). Quantification of the c-Fos induction after the social exposure showed neural activation in several brain regions associated with the olfactory information. GABA has been associated both with the development and function of different neurons in the olfactory system (Pallotto et al., 2012). However, no change was observed in the olfactory or the accessory olfactory bulb in the GAD67<sup>+/-</sup> mice, thus suggesting an overall activation of the olfactory neurons. In contrast, reduced c-Fos induction was evident in medial and cortical amygdala, bed nucleus of the stria terminalis, lateral septum dorsal and medial preoptic area in GAD67<sup>+/-</sup> male mice compared to GAD67<sup>+/+</sup> littermates. The olfactory sensory neurons project initially to the main and accessory bulb in the brain, which further directly projects into the medial and cortical amygdala. Medial amygdala is critical for processing of the social information especially in male mice (Murakami et al., 2011). Studies have shown lesion of medial amygdala to result in reduced aggression and sociability (Wang et al., 2013). The reduced c-Fos expression suggests a weak stimulation from the olfactory and poor activation of both medial and cortical amygdala. Medial amygdala mediates the detection of conspecific pheromone and the information



processing during sexual and non-sexual social behavior through the GABAergic neurons (Meredith and Westberry, 2004; Pereno et al., 2011). From the medial and the cortical amygdala the information is further passed onto the lateral septum dorsal, bed nucleus of the stria terminalis and medial preoptic area (Blake and Meredith, 2010). Both medial preoptic area and the bed nucleus of the stria terminalis are critical for social and sexual behavior especially in male mice (Powers et al., 1987). Studies have shown deficits in maternal behavior with injection of GABA receptor agonist in the medial preoptic area and bed nucleus of the stria terminalis in a dose dependent manner (Arrati et al., 2006). Furthermore, GABA has been associated with the modulation of various behaviors like maternal behavior and emotions in the lateral septum area (Zhao et al., 2013). Studies have shown critical function of GABA for the hormone mediated social behaviors. Thus culminating to GAD67 haplodeficiency disturbs the overall neuronal activation in output region of the olfactory system controlling the social behavior.

Central GABAergic mechanisms are involved in the control of gonadal hormone release (Dong et al., 2002; Penatti et al., 2010), and serum testosterone levels are known to determine aggression in male mice (Barkley and Goldman, 1977). However, I did not observe any change in testosterone levels in GAD67<sup>+/-</sup> mice. Positive allosteric modulators of GABA(A) receptors, such as alcohol, benzodiazepines and neurosteroids have previously been shown to stimulate aggression at low doses (Miczek et al., 2003) and social approach in rats was found sensitive to benzodiazepine treatment (Nicolas and Prinssen, 2006). These changes may be closely related to the anxiolytic effect of such GABAergic modulators. Therefore, I further investigated anxiety-like behavior in an open field, a light/dark avoidance test and a marble burying test, but I did not observe any change in behavior of GAD67<sup>+/-</sup> mice.

Thus, my data suggest that GAD67<sup>+/-</sup> mice display a specific disturbance of pheromone-dependent social and aggressive behavior. Evidence indeed suggests that GAD67 expressing interneurons may be involved in both, the recognition of pheromonal signals in the olfactory system, and in the control of pheromone-dependent social behavior, e.g. via the amygdala. For example, GAD is expressed in granule and periglomerular cells of the main and accessory olfactory bulb, which are involved in the circuits mediating feedback and lateral inhibition (Quaglino et al., 1999). GABAergic mechanisms are involved in the processing of pheromonal information in the accessory

olfactory bulb (Lagier et al., 2007; Pereno et al., 2011). GABAergic neurons in the accessory olfactory bulb also strongly express the pituitary adenylate cyclase activating polypeptide (PACAP) type 1 receptor (Hashimoto et al., 1996), genetic ablation of which disturbs social investigation and reduces aggression (Nicot et al., 2004). In females, detection of conspecific pheromones leads to an activation of GABAergic cells in the vomeronasal system and the medial extended amygdala (Pereno et al., 2011). Vasopressin and oxytocin, which are powerful mediators of social interactions via the vomeronasal/accessory olfactory bulb and the main olfactory bulb, and their pathways to the amygdala (Danzer 1988; Ferguson et al., 2001), also interact with GABAergic signalling. Both vasopressin and GABA are known to be co-expressed in neurons of the main olfactory bulb that are activated by social stimuli (Wacker et al., 2010). GABAergic mechanisms are also involved in the secretion of these peptides from the pituitary (Saridaki et al., 1989), but the vasopressin levels measured in the blood serum showed no significant difference between the genotype.

The mutant mice displayed a two-hour phase delay of circadian rhythm. The latter observation contrasts a previous study reporting unaltered sleep patterns of  $GAD67^{+/-}$  mice (Chen et al., 2010). However, Chen and co-workers investigated mutants on a Swiss Webster genetic background, which in contrast to C57Bl/6 shows strongly fragmented activity pattern (Van-Bogaert et al., 2006) that may have occluded the shift in activity evident in my study. Both depression-like behavior and shift of circadian rhythm were observed in experimentally naïve  $GAD67^{+/-}$  mice. Nevertheless, potential effects of social encounters during the pre-experimental phase must be taken into consideration. Social defeat has been shown to induce depression-like behavioral change in rodents as well as in humans (Golden et al., 2011). The effect of social stress on circadian rhythm is generally observed in form of sleep fragmentation or general activity reduction (Harper et al., 1996, Meerlo et al., 1997), rather than distinct phase shifts. However, delayed sleep phase syndrome has been described both in bipolar disorder (Plante and Winkelmann, 2008) and schizophrenia (Pritchett et al., 2012).

The study will be of relevance to understand the neural mechanism underlying psychiatric disorder. Most of the studies associated with psychiatric disorders especially related to schizophrenia are mostly limited to hippocampus and prefrontal cortex (Thompson et al., 2009). During my study, I observed reduction in olfactory function

**Chapter 2**

**Phytoestrogens mediated alteration in social-pheromone association and ablated aggression in C57Bl/6 male mice.**

**5.1. Introduction:**

Phytoestrogens are a plant source for soy and constitute a major protein source in commercial diet for laboratory mice. They are estrogens analogs and have been identified as potent anxiolytics (Lund et al., 2001). Phytoestrogens are known to exert a direct effect on brain estrogens receptors (Kostelac et al., 2003; Mueller et al., 2004) and an indirect effect on the circulating estrogens (Weber et al., 2001). Estrogens have been associated with different psychiatric disorders (Craig and Murphy, 2007; Cyr et al., 2002; Epperson et al., 1999). Estrogens treatment has been reported to be beneficial for schizophrenia cure (Bharadwaj et al., 2009; Kulkarni et al., 2001; Rakesh et al., 2011). Animal studies with estrogens show them to act in a similar manner to neuroleptics (Kulkarni et al., 1996). They are known to modulate cerebral neurotransmission and influence both mood and cognitive function (Cutter et al., 2003). Additionally they appear to have significant effects on serotonergic, noradrenergic, dopaminergic, cholinergic and glutaminergic systems (Amin et al., 2005; Chavez et al., 2010; Gibbs, 2010). Much evidence suggests estrogens that act as mild antipsychotics (Bergemann et al., 2005; Cyr et al., 2002), help reduce aggressive behavior (Finkelstein et al., 1997), improve cognitive function and affective symptoms (Sherwin, 2003). Estrogens are known to act as stress protectors and also known as “nature’s psychoprotectants” (Fink et al., 1996).

Reduction in the estrogens levels is associated with the onset of different psychiatric disorders (Douma et al., 2005; Meinhard et al., 2014; Seeman, 1996). Estrogens have shown to ameliorate the psychiatric condition via sustaining the neurotransmitter activity especially in schizophrenia and depression state (Cyr et al., 2002; Grigoriadis and Kennedy, 2002; Lindamer et al., 1997; Seeman and Lang, 1990). Additionally studies have shown an inverse correlation between the reduction of the serum estradiol and the onset of psychiatric symptoms in female subjects (Almeida et al., 2005; Gentile, 2005). It has been demonstrated that schizophrenic female patients with active menstrual cycles require reduced amount of the antipsychotic medication compared to the post menopausal female or male patients (Brockington et al., 1988; Dennerstein et al., 1983; Glick and Stewart, 1980). Single case studies in human subjects have shown recovery from the psychiatric condition with the uptake of the antipsychotic drugs

with estrogens administration (Lindamer et al., 1997; Seeman and Lang, 1990). Additionally, genes like COMT1 (catechol-o-methyl transferase), neuroregulin 1 and even GAD, are often associated with various psychiatric disorders and show association with estrogens metabolism (Cannon, 2005; Li et al., 2006; Riecher-Roessler and Geyter, 2007).

GAD the rate limiting enzyme, synthesizing GABA and associated with various psychiatric disorders (Brambilla et al., 2003; Guidotti et al., 2000; Kash et al., 1997; Pizzarelli and Cherubini, 2011; Yip et al., 2007) and show regulation by estradiol (McCarthy et al., 1995). Studies have shown the regulation of GAD expression both at the transcriptional and translational levels by estrogens (Brinton, 2001; Nakamura et al., 2004). Estrogens directly mediate both GAD65 and 67 mRNA expressions in different subregions of the brain including the amygdala (Murphy et al, 1998; Noriega et al, 2010; Weiland, 1992).

Additionally, estrogens are also known to modulate GABA through its interaction with the GABA(A) receptors (Herbison and Fenelon, 1995; Herbison, 1997). They are also associated with the regulation of ligand binding to GABA(A) receptor (Herbison and Fenelon, 1995). Estradiol is known to indirectly modulate GABA(A) receptor function (Lieb et al., 1994). *In vitro* studies with cultured hippocampal cells have shown estradiol to mediate down regulation of BDNF (brain-derived neurotrophic factor), followed by a reduction in inhibition and further by a decrease in GAD and GABA levels. Thus resulting in an increase in excitatory tone, with two-fold increase in dendritic spine (Murphy et al., 1998; Pytel et al 2007). Thus suggesting a plausible correlation between GABA/ GAD and estrogens.

Therefore, in my study I tried to investigate the role of estrogens in GAD function. To address this question, I opted for a non-invasive approach to validate changes in GAD mediated behavior with the administration of different phytoestrogens diets. Most of the studies related to phytoestrogens require chronic administration of phytoestrogens to maintain stable levels of phytoestrogens metabolite in the blood. (Ranich et al., 2001; Roberts et al., 2000).

The aim of my study design was to validate:

Does phytoestrogens deficit state mimic phenotypic state of social behavior impairment and ablation in aggression as phenotyped in GAD67<sup>+/-</sup> mice?

Does phytoestrogens treatment rescue this effect at a phenotypic level and can be suggested as treatment in conditions with ablated GAD levels?

## 5.2. Experiment design:

**Table 7.1.** Here I tabulated the different test I used to address the role of phytoestrogen in social behavior regulation. The detail description of the method for reference has been mentioned in the method section (page 24-59).

| Test                   | Sub test                        | Test type  |
|------------------------|---------------------------------|--|
| <b>Behavioral test</b> | Social interaction Test         | One partner interaction<br>(N=15 phyto0; N= 10 phyto150 treated mice)            |
|                        |                                 | Male vs. Female interaction<br>(N=8 phyto0; N= 8 phyto150 treated mice)          |
|                        | Social odor identification test | Social (male) vs. non social odor<br>(N=8 phyto0; 8 phyto150 treated mice)       |
|                        |                                 | Social (female) vs. non social odor<br>(N= 8 phyto0; N= 8 phyto150 treated mice) |
|                        |                                 | Male vs. female odor<br>(N= 8 phyto0; N= 8 phyto150 treated mice)                |
|                        | Odor sensitivity test           | Non social (rose) odor test<br>(N= 8 phyto0; N= 8 phyto150 treated mice)         |
|                        |                                 | Social pheromone odor test<br>(N= 8 phyto0; N= 8 phyto150 treated mice)          |
|                        | Aggression test                 | Resident intruder test<br>(N= 8 phyto0; N= 8 phyto150 treated mice)              |
|                        | Biological activity             | Home cage activity<br>(N= 15 phyto0; N= 10 phyto150 treated mice)                |

| Test                          | Sub test   | Sub group  |
|-------------------------------|--|--|
| <b>Behavioral test</b>        | Biological activity  | Nest building test<br>(N= 8 phyto0; N= 9 phyto150 treated mice)  |
|                               | Innate behavior Test   | Urine marking test<br>(N= 8 phyto0; N= 8 phyto150 treated mice)  |
| <b>Hormone quantification</b> | Blood serum Test   | Testosterone test<br>(N= 6 phyto0; N= 6 phyto150 treated mice)   |
|                               |  | Estradiol test<br>(N= 6 phyto0; N= 6 phyto150 treated mice)  |
|                               |  | Vasopressin test<br>(N= 6 phyto0; N= 6 phyto150 treated mice)  |
| <b>Immuno-histochemistry</b>  | Quantification of c-Fos activation in different regions post social stimuli exposure | c-Fos quantification in Olfactory bulb (AOB: Accessory olfactory bulb, GL: Glomeruli cells, GC: Granular cells), forebrain (LSD: Lateral septum dorsal, BNsT: Bed nucleus of the stria terminalis, MPOA: Medial preoptic area) and Amygdala (MeA: Medial amygdala, CoA: Cortico-medial amygdala ) (N= 6 phyto0; 6 phyto150 treated mice) |

Animals used during the test were naive. Only mice used in the non social and social choice test were repeated. During the test there was a recovery time of 8 days.

#### **Statistical analysis:**

Statistical analysis was done with Student's t test for pairwise comparison of the groups. Repeated measures analysis of variance (ANOVA) and Bonferroni's *post hoc* test was done as appropriate.



### 5.3 Results

#### 5.3.1. Decrease in preference for social interaction with phyto0 treatment:

To validate does phyto0 diet treatment in C57Bl/6 male mice effects social interaction when given a choice between animal (male)-empty and male-female interactions. The test design was similar to the social interaction test mentioned in the previous chapter. Social preference in C57Bl/6 male mice treated with two different diets (phyto150 or phyto0) was measured in preference choice between an unfamiliar male mouse versus an empty compartment. The phyto0 treated test mice showed significant reduction in preference towards social interaction compared to control mice (contact index  $-25.4 \pm 13.8$  on phyto0 vs.  $26.2 \pm 19.4$  on phyto150, Student t test  $t(22)=5.8$ ,  $p < 0.0001$ ; Time index  $-40.2 \pm 14.6$  on phyto0 vs.  $40.1 \pm 18.7$  on phyto150,  $t(22)=8.7$ ,  $p < 0.0001$ ; Fig. 34 A,B).

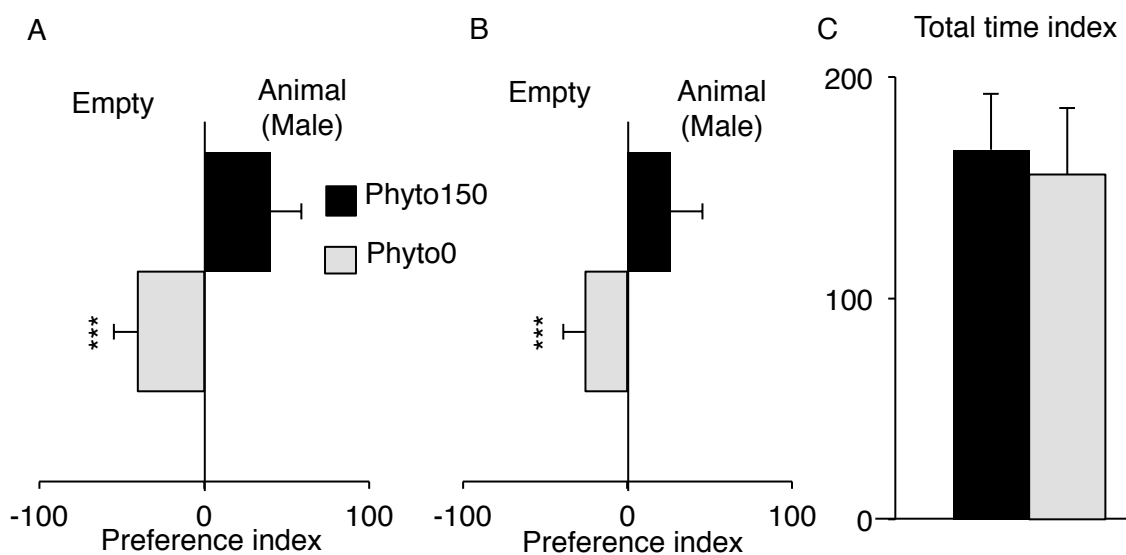

**Fig. 34.** Social interaction with animal (male) vs. empty preference index: attenuation in preference for social interaction partner with phyto0 diet in contact time index (A) and contact number index (B). Total time index remained unchanged between the two diets. All values are showed in mean $\pm$ SEM: \*\*\* $p < 0.001$ .

Zone index i.e., a quantification of the time spend by the mice in each zone showed a marked reduction in the phyto0 mice compared to the phyto150 treated mice (zone time index  $-17.4 \pm 13.1$  vs.  $12.1 \pm 11.8$  on phyto150;  $t(22)=4.3$ ,  $p < 0.001$ ).

The total exploration time value showed no significant change between the two dietary treatments ( $155.9 \pm 29.97$  on phyto0 vs.  $167.1 \pm 24.4$  on phyto150;  $t(22)=0.7$ ,  $p=0.46$ ; Fig. 34. C).

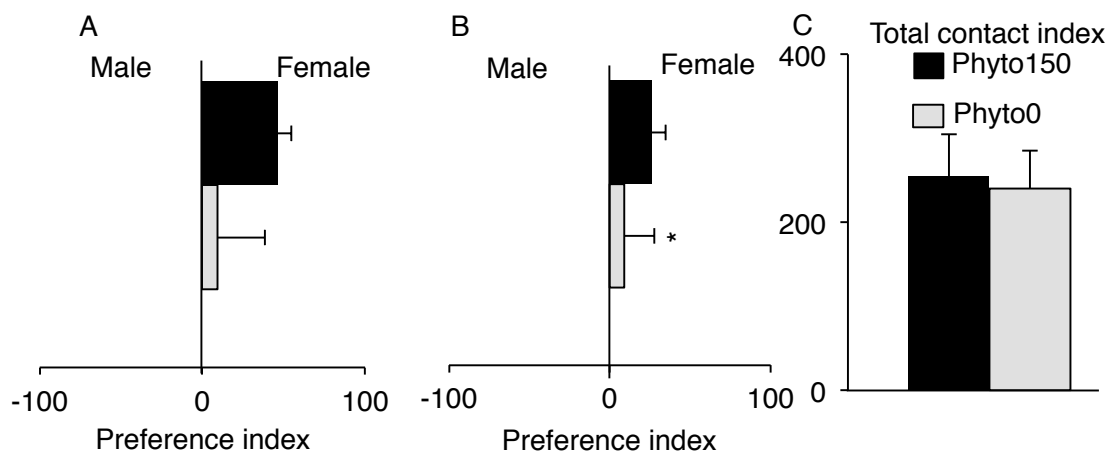
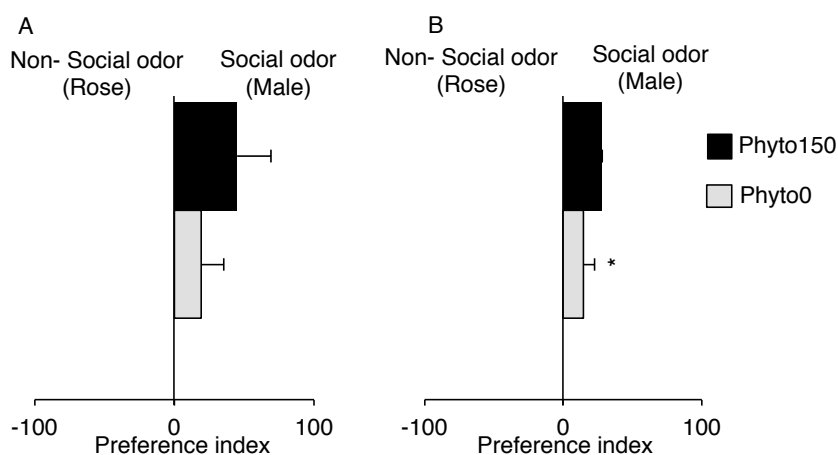

**Fig. 35.** Preference index for male vs. female social interaction paradigm: an overall reduction in contact time (A) and contact index (B) preference for female interaction partner was observed in phyto0 treated mice in social interaction paradigm. The total time index remained was not affected with the two diets (C). All values are showed as mean $\pm$ SEM: \*  $p < 0.05$ .

To further validate if phytoestrogen diet treatment also interferes with social preference i.e., male vs. female as observed in  $GAD67^{+/-}$  mice. Test mice on phyto0 diet showed an overall reduction in the preference for the compartment with the female mice compared to the male mice (contact number index  $9.0 \pm 18.6$  on phyto0 vs.  $25.9 \pm 8.8$  on phyto150;  $t(13)=1.5$ ,  $p=0.07$ ; Fig. 35. B). Contact time index showed a significant reduction in the overall time spend by phyto0 treated mice ( $9.3 \pm 29.2$  vs.  $46.5 \pm 8.1$  on phyto150,  $t(13)=2.5$ ,  $p < 0.05$ ) exploring and contacting the unfamiliar female compared the phyto150 treated test mice (Fig. 35. A). Total time index showed no change between the groups ( $84.6 \pm 13.1$  vs.  $97.4 \pm 9.9$  on phyto150,  $t(13)= 0.2$ , n.s.; Fig. 35. C). Both the genotype spend similar time exploring the tubes.

### 5.3.2. Impaired inclination for social odor on phyto0 diet:

Social odor has been a critical measure to validate intact social behavior and communication. Olfactory function and odor assessment are important for mating, social identification, threat assessment, territorial protection and hierarchy maintenance (Arakawa et al., 2008; Silverman et al., 2010). To investigate the deficit observed in the social interaction paradigm in phyto0 treated mice, also interferes with the social and non social odor identification. Firstly, the test animals were given a choice between social odor (male bedding) and non social odor (rose essence). Phyto0 treated animals showed an overall reduction in the contact time index and contact number index against the value measured by phyto150 diet treated mice. Interestingly, there was significant decline in the contact number index by phyto0 treated mice (contact number index:  $14.5 \pm 8.1$ ; time index:  $19.5 \pm 16.1$ ) for the tube containing the social odor (soiled male bedding) compared to the phyto150 treated mice, with a high preference for social odor assessment (contact number index:  $27.2 \pm 7.04$ ;  $t(13)=2.3$ ,  $p < 0.05$  and time index:  $45.0 \pm 24.3$ ,  $t(13)=1.6$ , n.s.) (Fig. 36. A, B).

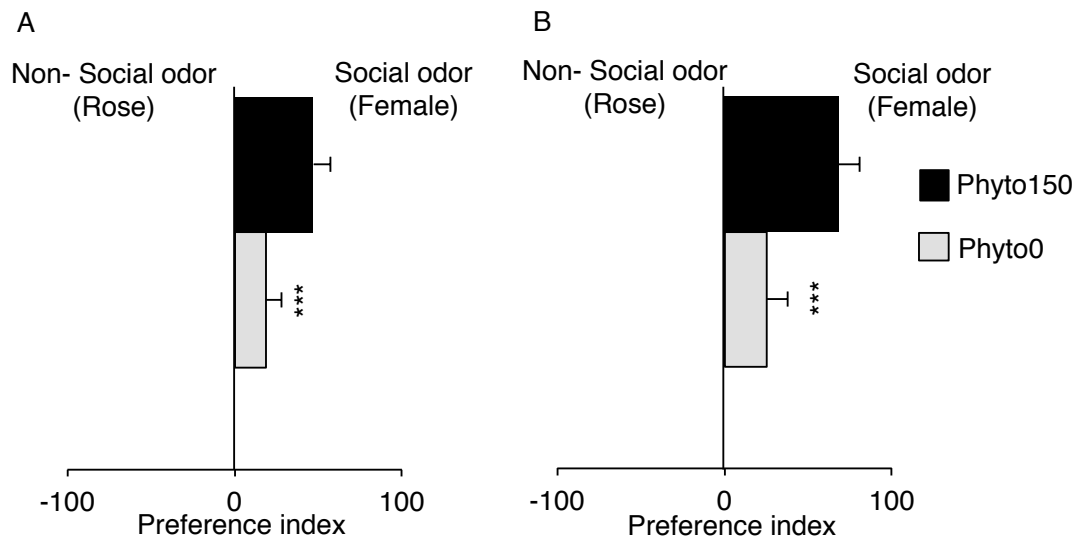

**Fig. 36.** Odor assessment between the social (male) vs. non social odor: The mice on phyto0 diet showed a reduction in contact time index (A) and contact number index (B) when compared to the phyto150 treated mice. All values are showed in mean±SEM:

\*  $p < 0.05$ .

Secondly, a similar decline in female odor predisposition was measured in the test mice on phyto0 treatment in contact number and time index when compared to the control phyto150 treated mice (contact index:  $18.8 \pm 9.2$  vs.  $47.03 \pm 10.3$  on phyto150;  $t(13)=4.0$ ,  $p < 0.001$  and time index:  $25.1 \pm 12.9$  vs.  $68.3 \pm 12.5$  phyto150;  $t(13)=4.6$ ,  $p < 0.001$ ; Fig. 37 A,

B). Zone time showed only a slight reduction on the time spend by the phyto0 treated mice in the zone with female bedding compared to the control mice ( $16.5 \pm 10.1$  phyto0 vs.  $25.5 \pm 12.5$  phyto150;  $t(13)=0.9$ , n.s.).



**Fig. 37.** Odor assessment between the social vs. non social odor. Significant reduction in the odor preference for the female odor on phyto0 diet both in the contact time index (A) and contact number index (B). All values are showed in mean $\pm$ SEM: \*\*\* $p < 0.001$ .

Lastly, the test mice were offered a choice between unfamiliar male and female soiled bedding samples. It is the natural sexual preference for male mice to be inclined towards a female odor compared to a male odor. Interestingly, phyto0 treated mice showed both decline in exploration and assessment of female odor compared to the phyto150 treated mice (contact index  $-8.7 \pm 9.6$  vs.  $14.1 \pm 6$  on phyto150;  $t(13)=3.8$ ,  $p < 0.01$  and time index  $-11.8 \pm 17.9$  vs.  $22.04 \pm 8.3$  phyto150;  $t(13)=3.0$ ,  $p < 0.01$ ; Fig. 38. A, B).

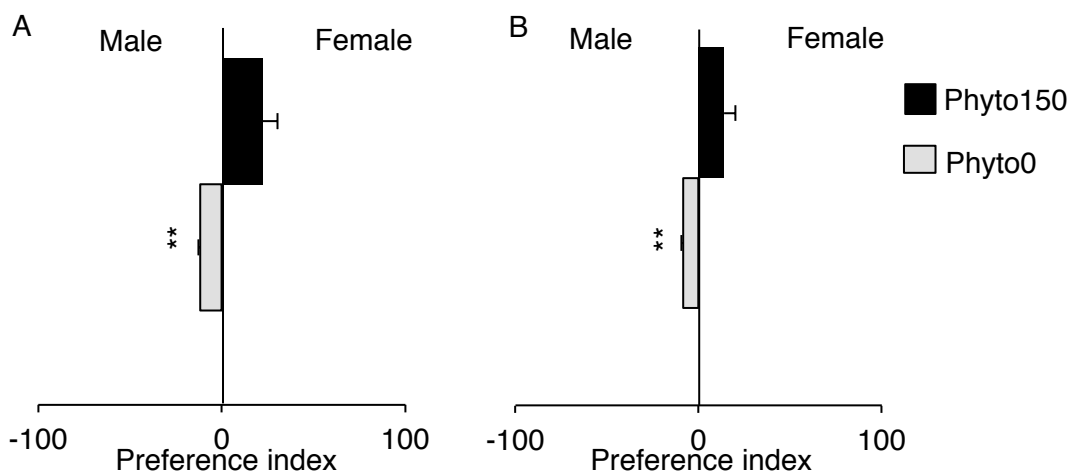
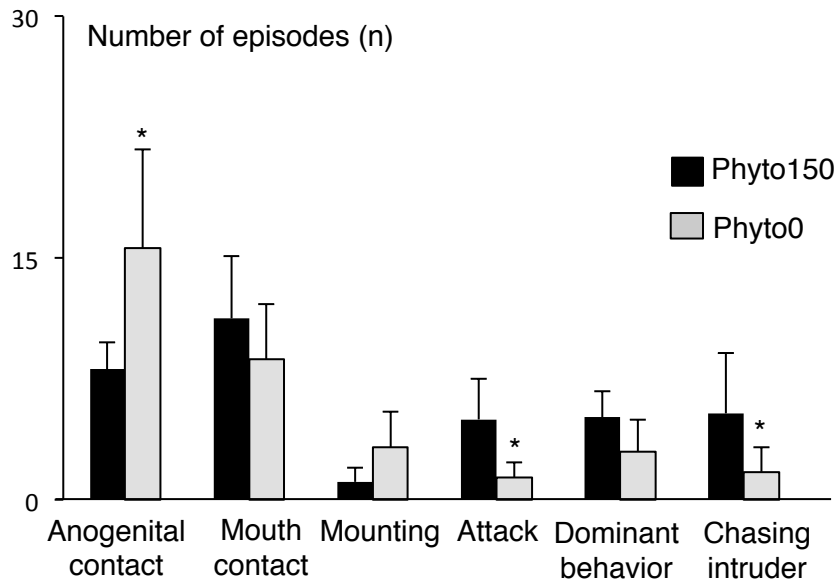

**Fig. 38.** Male and female odor assessment. An overall reduction in the contact time index (A) and contact number index (B) was observed for female odor assessment with phyto0 diet treated mice compared to phyto150 diet mice. All values are showed in mean $\pm$ SEM:

\*\* $p < 0.01$ .

### 5.3.3. Attrition of aggression by phyto0:

Estrogens have been associated with modulation of brain network that regulate the territorial aggression in male mice (Wu et al., 2009). Therefore I investigated the role of phytoestrogens in the territorial aggressive behavior of male mice. Test mice on phyto0 displayed attenuation in the number of attacks ( $1.4 \pm 0.97$  n) during encounter with an unfamiliar male intruder compared to phyto150 treated mice ( $5.0 \pm 2.5$  n;  $t(13)=2.2$ ,  $p < 0.05$ ). Interestingly, there was an evident escalation in the total number of anogenital sniffing detected on phyto0 ( $15.6 \pm 6.1$  n) compared to the phyto150 diet ( $8.1 \pm 1.7$  n;  $t(13)=2.7$ ,  $p < 0.05$ ). This was accompanied with an increase in the number of mounting of the intruder by the resident mice treated with phyto0 then treated with phyto150 ( $3.3 \pm 2.3$  n vs.  $1.1 \pm 0.9$  n;  $t(13)=1.9$ , n.s.; Fig. 39.). Whereas dominant behavior (cornering of the intruder) and intruder chasing were observed more in phyto150 ( $5.1 \pm 1.6$  n) treated mice compared to phyto0 ( $3.0 \pm 2.0$  n;  $t(13)=2.0$ , n.s.; Fig. 39.). Mouth contact remained unchanged between the two diets ( $8.8 \pm 3.4$  n vs.  $11.3 \pm 3.9$  n phyto150;  $t(13)=0.9$ , n.s.; Fig. 39.).



**Fig. 39.** Resident-intruder aggression test. Graph displaying the value of the different aggressive and interaction behavior measured during the test. All values are showed in mean $\pm$ SEM: \*  $p < 0.05$ .

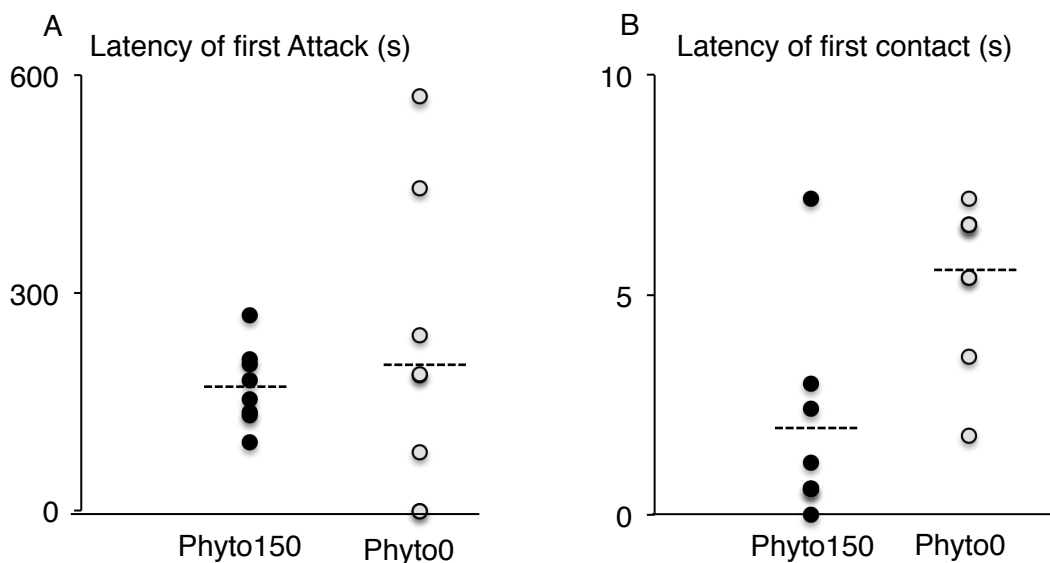

**Fig. 42.** Delay in latency to initiate an attack and first contact in mice on phyto0 diet. Dot distribution showing the latency to initiate the aggressive behaviors: attack (A) and initial contact (B) towards the intruder on phyto0 and phyto150 diet.

Animal on phyto0 diet showed an increase in latency to initiate an attack ( $285.2 \pm 170.5$  s) compared to phyto150 treated littermates ( $171.8 \pm 43.4$  s;  $t(13) = 0.9$ , n.s.; Fig. 42 A, 43). Interestingly there was a delay to initiate contact towards the intruder mice by the

resident mice on phyto0 diet compared to the phyto150 diet treated mice ( $5.4 \pm 1.4$  s phyto0 vs.  $1.9 \pm 1.7$  s phyto150;  $t(13)=3.4$ ,  $p < 0.01$ ; Fig.42 B, 43). Similarly phyto0 diet treated animals showed an increase in latency to chase the intruder during the test ( $128.3 \pm 26.3$  s phyto0 vs.  $58.1 \pm 36.8$  s phyto150;  $t(13)=2.4$ ,  $p < 0.05$ ; Fig. 42). Other behavioral contacts like mounting ( $114.0 \pm 78.0$  s phyto0 vs.  $64.9 \pm 62.3$  s phyto150;  $t(13)=0.9$ , n.s.), mouth contact ( $27.1 \pm 25.0$  s phyto0 vs.  $14.3 \pm 12.5$  s phyto150;  $t(13)=1.1$ , n.s.), and anogenital contact ( $9.4 \pm 3.3$  s phyto0 vs.  $6.9 \pm 2.5$  s phyto150;  $t(13)=0.9$ , n.s.) showed no significant change between the diets (Fig. 43).

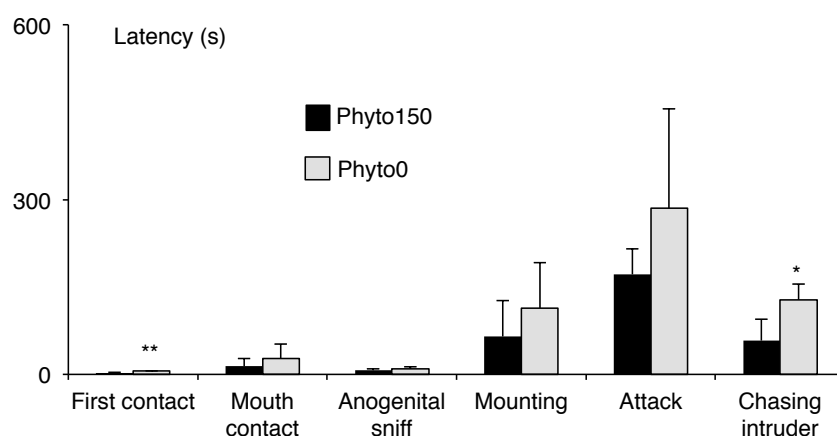

**Fig. 43.** Distribution of the latency in different behavior outputs measured in aggression tests. Animals on phyto0 diet displayed an overall increased latency to initiate attacks or related aggressive behavior compared to phyto150 treated mice. All values are mean $\pm$ SEM: \*\*\* $p < 0.001$ , \*\* $p < 0.01$ , \*  $p < 0.05$ .

#### 5.3.4. Nest building behavior remain intact between the two diets:

To enquire, if the social and olfactory deficit observed in phyto0 mice interfere with the innate nest building behavior. Amount of nest building material collected increased over the test period of 24 h but no effect between the diets was observed (repeated measures ANOVA time  $F(1,16)=67.5$ ;  $p < 0.001$  and time\*diets  $F(1,16)=0.0$ , n.s.). After 24 h animals on both the diets showed same complexity of nest building  $3.4 \pm 0.4$  type in phyto0 and  $3.6 \pm 0.5$  type in phyto150; Student's t-test:  $t(15)=0.8$ , n.s.; Fig. 45.). Thus suggesting no evidence for quantitative difference between the diets.

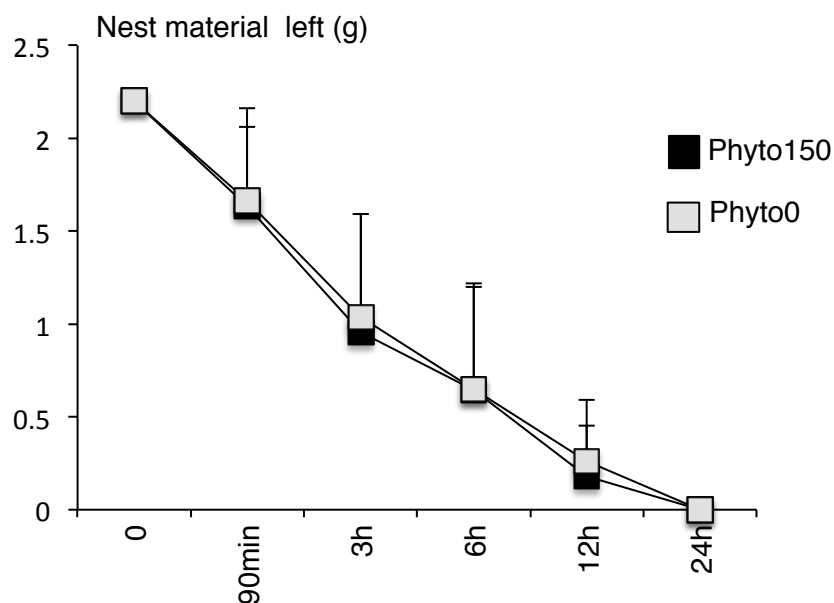
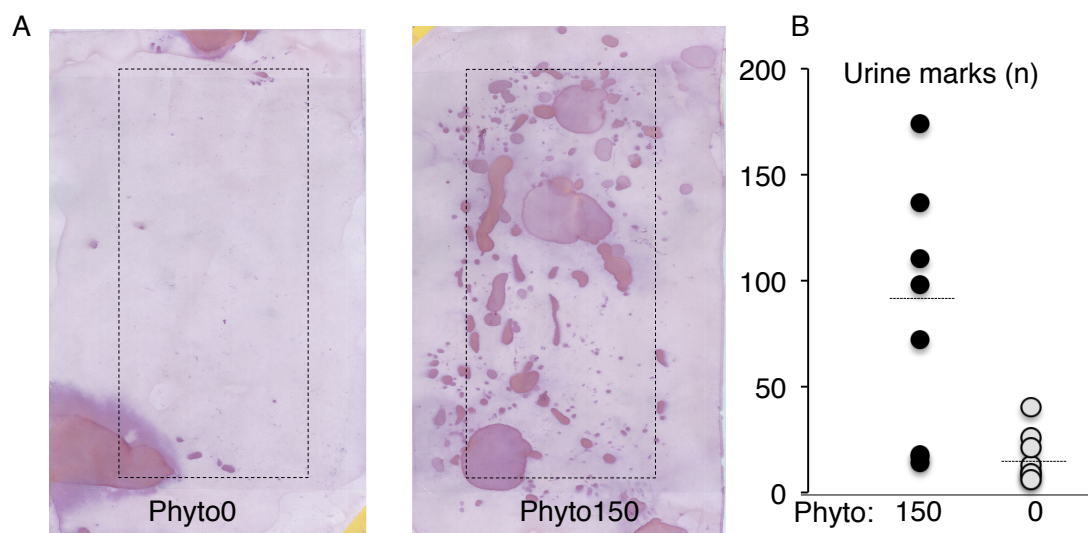

**Fig. 45.** Nest building behavior. The nest building material during the test showed no difference between the two diets (phyto150 and phyto0). All values are mean $\pm$ SEM.

### 5.3.5. Altered urine markings in phyto0 treated mice:

Evidence suggests the role of estrogens in activation of male aggression and urine marking (Wu et al., 2009). Therefore I validated if phytoestrogens interfere with the urine markings pattern in male mice. The urine pattern were quite distinct between the two diet treatments with phyto150 control mice marked always near the center whereas phyto0 treated mice avoided to mark the center field (Fig. 46. A). Quantification of urine markings of the center field (28x12 cm) showed a significant reduction in the urine marks in mice on phyto0 (16.6 $\pm$ 9.3 n) compared to phyto150 treated mice (89.0 $\pm$ 46.6 n;  $t(14)=2.9$ ,  $p<0.05$ ; Fig. 46. A, B).

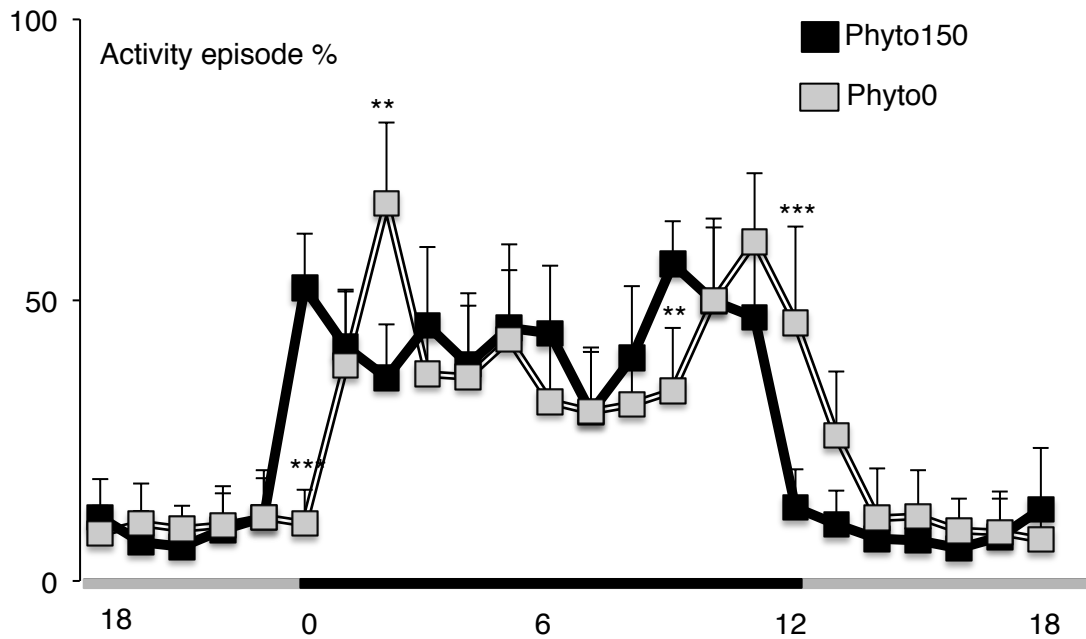



**Fig. 46.** Urine marking test. The filter paper showed the urine mark pattern made by the mice during the test (A). Dot graph display the number of urine marks (n) made by individual mouse in the center field during the test from the two diets group (B). The dotted line represents the mean in both groups.

### 5.3.6. Delayed diurnal rhythm in C57BL/6 mice on phyto0 diet:

Home cage activity in  $GAD67^{+/-}$  mice showed an overall 2 h shift in the activity pattern. This data was critical to appraise if phyto0 treatment mimics disturbed diurnal rhythm as reported earlier in  $GAD67^{+/-}$  mice. Examination of the data from the home cage activity revealed a 1 h shift in the activity pattern of the test mice on phyto0 diet treatment (Fig. 47). During the test phyto0 treated mice showed a change during the shift between the two phases: inactive to active at ZT1 (exercised one hour after light off) and vice versa ZT13 (proceeding one hour after the light on). Thus the two dietary treatments led to a significant difference of activity at ZT1 ( $10.3 \pm 5.9\%$  phyto0 vs.  $52.2 \pm 25.1\%$  phyto150; Student's t-test  $t(22)=4.6$ ,  $p < 0.0001$ ) and ZT13 ( $45.9 \pm 17.1\%$  on phyto0 vs.  $13.1 \pm 6.6\%$  phyto150;  $t(22)=4.6$ ,  $p < 0.01$ ), ZT14 ( $25.8 \pm 11.5\%$  on phyto0 vs.  $9.9 \pm 7.9\%$  phyto150;  $t(22)=2.9$ ,  $p < 0.01$ ). Also the delay in the overall activity resulted in shifting the activity % on phyto0 diet towards the left side which resulted in significant change in activity during active phase at ZT3 ( $67.2 \pm 14.4\%$  on phyto0 vs.  $36.1 \pm 20.0\%$  phyto150;  $t(22)=4.5$ ,  $p < 0.001$ ) and at ZT10 ( $33.8 \pm 11.2\%$  on phyto0 vs.  $56.4 \pm 17.7\%$  phyto150;  $t(22)=2.7$ ,  $p < 0.01$ ).

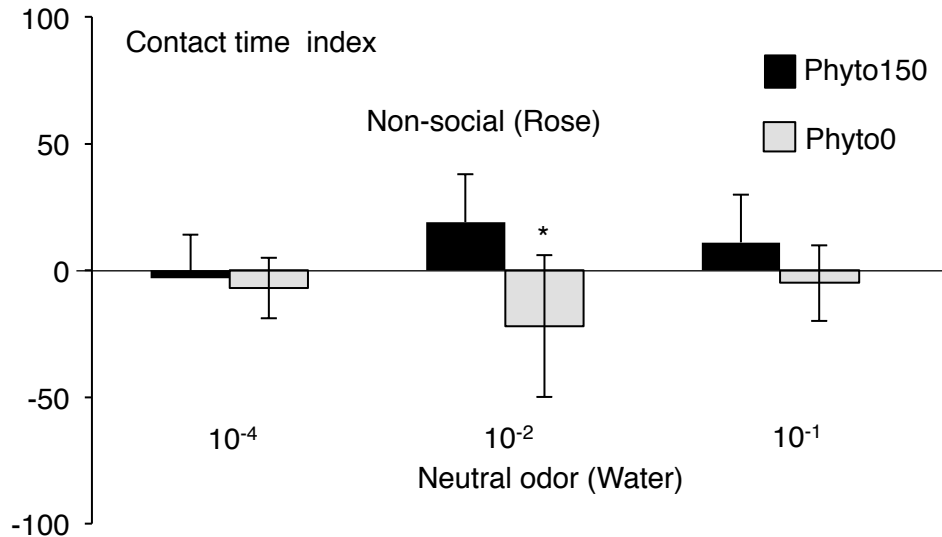

**Fig. 47.** Home cage activity measured in mice treated with phyto150 and phyto0 diet. 1 h delay in the activity episode % was observed during phase change i.e. active to inactive and vice versa in phyto0 treated mice. All values are mean $\pm$ SEM \*\*\* $p < 0.001$ , \*\* $p < 0.01$ .

### 5.3.6. Increase odor sensitivity at higher concentration by phyto0 treated mice

As observed in the previous chapter the impaired social identification and pheromone identification has been associated with olfactory impairment. Studies with knockout mice have shown social deficits in mice with estrogens receptor deletion (Kavaliers et al., 2004). Hence I investigate does the deficit in the phytoestrogens interfere with the olfactory function. Phyto0 diet administered mice showed impaired identification of the non social (rose) odor compared to the phyto150 treated mice at different dilution: dilution factor of  $10^{-4}$  (rose odor: contact index  $-4.0 \pm 10.0$  in phyto0 vs.  $1.0 \pm 13.0$  in phyto150;  $t(13) = 0.7$ , n.s.; time index  $-7.0 \pm 12.0$  in phyto0 vs.  $-3.0 \pm 17.0$  in phyto150;  $t(13) = 0.4$ , n.s.), dilution factor  $10^{-2}$  (rose odor: contact index  $-14.0 \pm 13.0$  in phyto0 vs.  $12.0 \pm 8.0$  in phyto150,  $t(13) = 3.2$ ,  $p < 0.01$ ; time index  $-22.0 \pm 28.0$  in phyto0 vs.  $19.0 \pm 19.0$  in phyto150,  $t(13) = 2.4$ ,  $p < 0.05$ ) and dilution factor of  $10^{-1}$  (rose odor: contact index  $-1.0 \pm 9.0$  in phyto0 vs.  $6.0 \pm 9.0$  in phyto150,  $t(13) = 1.2$ , n.s.; time index  $-5.0 \pm 15.0$  in phyto0 vs.  $11.0 \pm 19.0$  in phyto150,  $t(13) = 1.0$ , n.s.). Even at a reduced dilution phyto0

administered mice showed reduced odor identification compared to the phyto150 treated mice (Fig. 48.).



**Fig. 48.** The odor sensitivity test with non social (rose) odor between the two diets. There was an overall impaired reduction in the odor preference at lower dilution with phyto0 diet compared to the phyto150 diet treated mice. All values are mean±SEM: \*  $p < 0.05$ .

Olfactory function is known to be associated with social behavior in rodents (Feierstein et al., 2010; Feierstein, 2012). Interestingly, mice on phyto0 diet showed impairment in the preference for the female pheromone even at a higher concentration (female pheromone dilution factor  $10^{-2}$ : contact index:  $-8.0 \pm 9.5$  in phyto0 vs.  $-2.0 \pm 17.9$  in phyto150,  $t(13)=0.4$ , n.s.; time index:  $4.0 \pm 18.1$  in phyto0 vs.  $-3.0 \pm 15.7$  in phyto150  $t(13)=0.7$ , n.s., dilution factor  $10^{-1}$ : contact index:  $-1.0 \pm 14.5$  in phyto0 vs.  $-8.0 \pm 12.1$  in phyto150  $t(13)=0.7$ , n.s.; time index:  $-1.0 \pm 31.4$  in phyto0 vs.  $-5.0 \pm 26.9$  in phyto150,  $t(13)=0.2$ , n.s. and dilution factor 1 contact index:  $23.0 \pm 19.1$  in phyto0 vs.  $30.0 \pm 16.2$  in phyto150,  $t(13)=0.6$ , n.s. ; time index:  $39.0 \pm 15.9$  in phyto0 vs.  $60.0 \pm 12.2$  in phyto150,  $t(13)=2.1$ ,  $p < 0.05$ ; Fig. 49.).

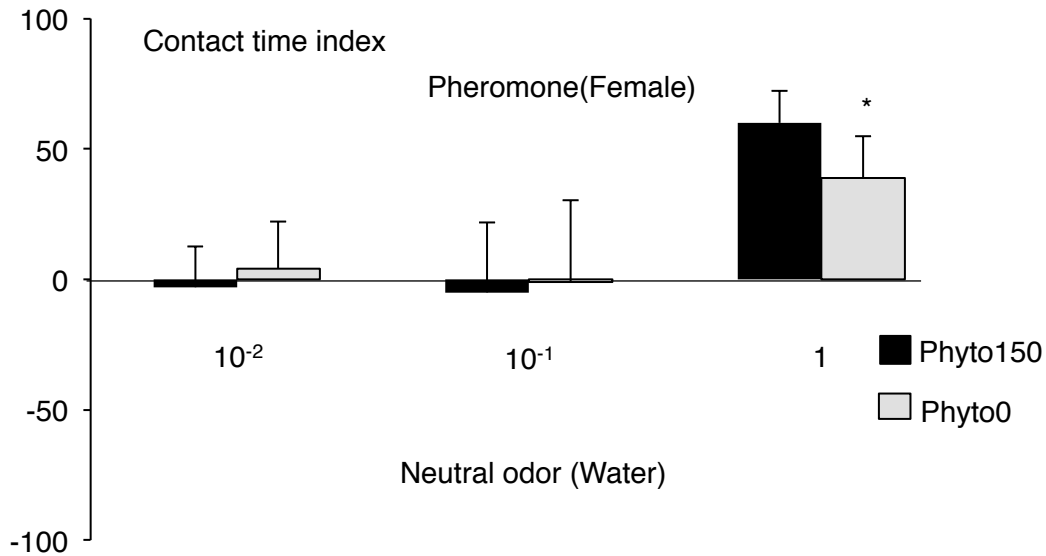

**Fig. 49.** The odor sensitivity test to social (female pheromone) odor in phyto150 and phyto0 treated mice. The phyto0 treated mice showed an overall reduction in the odor preference at lower pheromone dilutions compared to the phyto150 treated mice. All values are mean $\pm$ SEM: \*  $p < 0.05$ .

### 5.3.7. Testosterone and 17 $\beta$ -estradiol remained unchanged between the diets:

Study has shown estrogens receptors modulate socially motivated behavior in mice (Imwalle et al., 2002). Weber et al., (2001) showed phytoestrogens to alter testosterone blood levels in rats. Henceforth to account for a potential indirect phytoestrogen effect on social behavior via changes in circulating levels of testosterone and 17 $\beta$ -estradiol, I determined their concentration in blood serum on both dietary treatments. Statistical analysis showed no significant change in 17 $\beta$ -estradiol levels in blood serum effect (1.9 $\pm$ 1.1 pg/mL phyto0 vs. 4.3 $\pm$ 3.0 pg/mL phyto150;  $t(10)=1.5$ , n.s.; Fig. 50. A) or in testosterone levels (1.46 $\pm$ 0.1 ng/mL phyto0 vs. 1.48 $\pm$ 0.1 ng/mL phyto150;  $t(9)=0.2$ , n.s.; Fig.50. B).

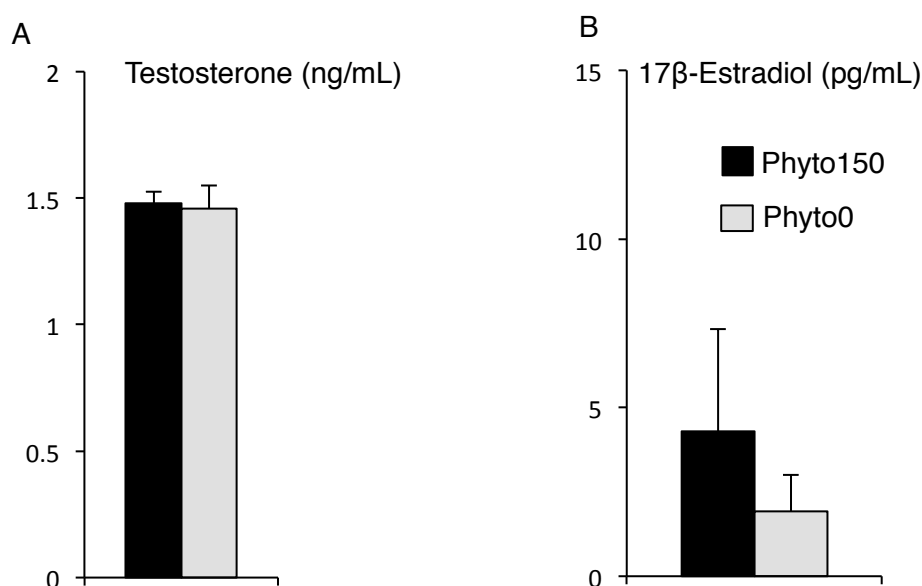

**Fig. 50.** Blood serum measurement of hormone levels with ELISA. No change was observed between the two diets in testosterone (A) and the 17 $\beta$ -estradiol (B) levels in the blood serum. All values are mean $\pm$ SEM.

#### **5.3.8. Normal vasopressin concentrations between the two diets:**

Social interaction in male is mediated through interaction between the estrogens receptors and vasopressin (Murakami et al., 2011). Male mice with deletion of vasopressin receptor show reduction in aggression and altered social behavior (Wersinger et al., 2002). Henceforth to validate the effect phytoestrogens on the vasopressin levels and to check the social and aggressive ablation is associated with altered vasopressin levels. No significant difference between the diets was observed in the blood serum vasopressin level (20.1 $\pm$ 15.9 pg/mL phyto0 vs. 16.8 $\pm$ 17.3 pg/mL phyto150;  $t(9)=0.2$ , n.s.; Fig. 51.).

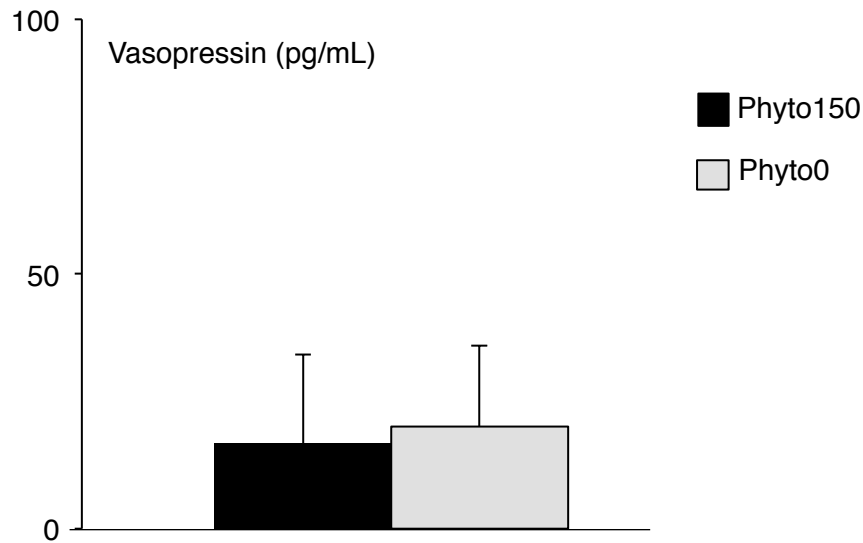

**Fig. 51.** Vasopressin ELISA blood serum measure. No change between the two diets was observed in the vasopressin levels in the blood serum. All values are mean $\pm$ SEM.

### **5.3.9. Change in c-Fos expression in subregions associated with social interaction with phyto0 diet:**

Estrogens are known to be associated with the regulation of social behavior at functional and molecular level (Choleris et al., 2003; Wu et al., 2009). Here I investigated whether the social and olfactory deficit I observed during various behavior test in mice on phyto0 diet are associated with a weak neuronal activation of different subregions. Therefore I quantified the c-Fos expression in different regions of the brain associated with social interaction. Similar to  $GAD67^{+/-}$  c-Fos quantification in the brains were fixed, one hour after social interaction paradigm exposure.

**Table 7.2.** The table shows c-Fos cell profile (cells/area mm<sup>2</sup>) in the different subregions of the brain associated with social behavior between the two diets:

| Region | Phyto0     | Phyto150   | P value    |
|--------|------------|------------|------------|
| AOB    | 220.9±33.8 | 189.3±90.8 | 0.6        |
| GC     | 357.4±30.7 | 276.1±97.5 | 0.2        |
| GL     | 89.4±14.3  | 77.5±16.4  | 0.3        |
| MeA    | 65.6±14.9  | 221.5±73.5 | 0.002; **  |
| CoA    | 129.1±43.6 | 292.5±70.2 | 0.004; **  |
| LSD    | 51.4±25.0  | 183.4±78.3 | 0.01; **   |
| BNsT   | 85.4±18.9  | 248.1±57.6 | 0.001; *** |
| MPOA   | 48.7±11.8  | 159.0±12.6 | 0.001; *** |

\*p<0.05; \*\* p<0.01; \*\*\*p<0.001

Different layers such as accessory olfactory bulb (AOB), granular cell layers (GC) and glomeruli (GL) were quantified to assess proper function of the initial olfactory input between the two groups (Table 7.2.; Fig. 53). No change was observed in the olfactory regions i.e., AOB, GC and GL between the c-Fos activated cells between the two diets (Table 7.2. ; Fig. 52, 53). The olfactory information is further transferred into the medial amygdala (MeA) and the direct input from the olfactory bulb goes to the cortical amygdala (CoA) Interestingly, a significant reduction in the cells labelled with c-Fos was observed in the phyto0 treated mice compared to the phyto150 mice (Table 7.2.; Fig. 53). The information from the medial amygdala is further passed and processed in the forebrain regions like the lateral septum (LSD), the bed nucleus of the stria terminalis (BNsT) and the medial preoptic area (MPOA). Quantification of c-Fos expression showed a significant weak activation of the regions (MeA, CoA, LSD, BNsT and MPOA) associated with social behavior in phyto0 treated mice (Table 7.2. ; Fig. 52.).

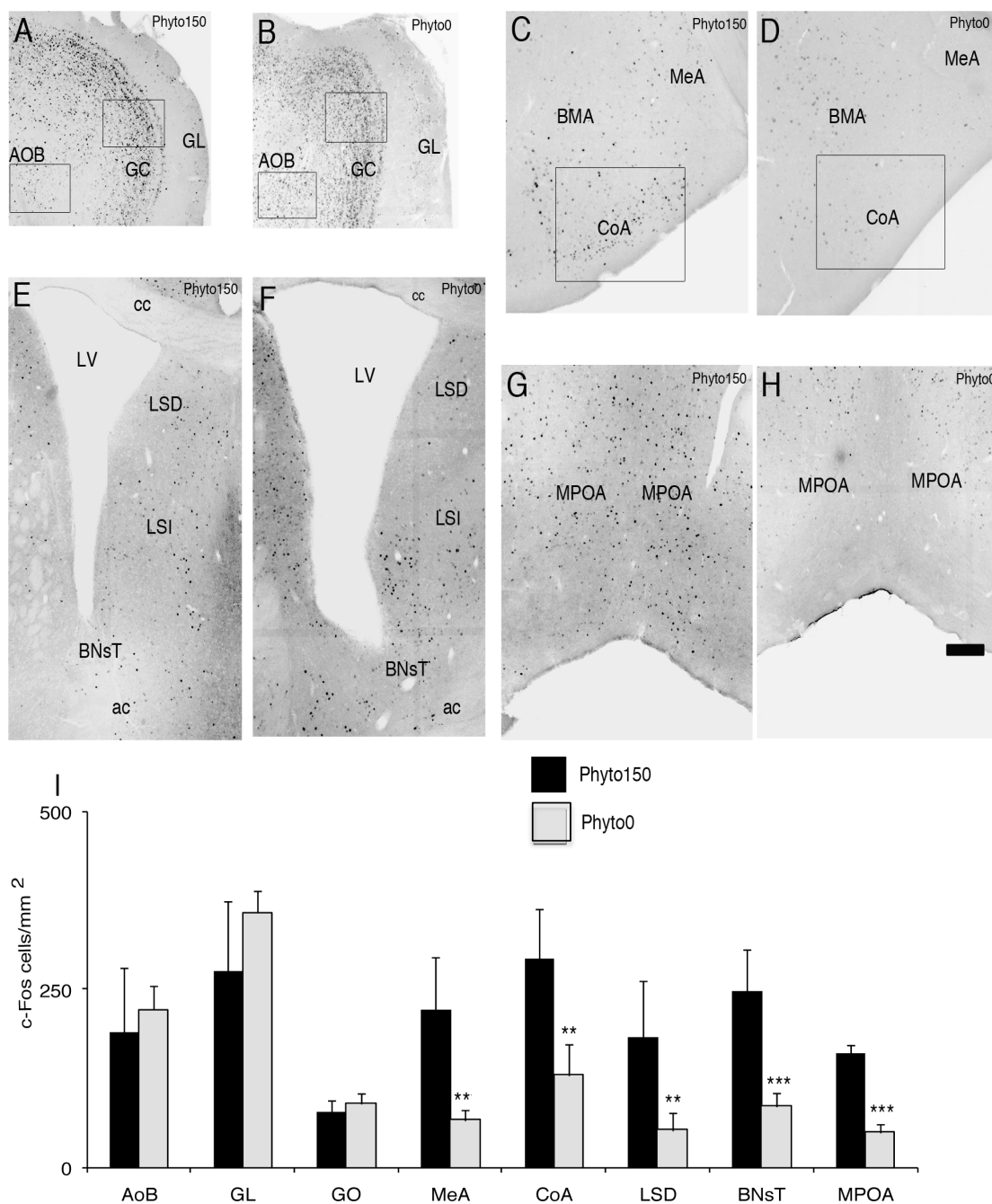

**Fig. 49.** Reduced c-Fos expression in phyto0 treated mice after social encounter. c-Fos labeling was evaluated in coronal sections from phyto150 (A,C,E,G) and phyto0 (B,D,F,H) mice, as an indicator of neural activity 1h after social stimulation. Comparable staining intensity between diets was observed in (A, B) the accessory olfactory bulb (AOB), and the granule cell layer of the olfactory bulb (GC), as well as the glomerular layer of the olfactory bulb (GL). However, reduced c-Fos immunoreactivity was found in phyto0 mice in various brain regions controlling social behavior, including (C, D) the medial (MeA) and cortical



amygdala (CoA). The lateral septum, dorsal (LSD) and as well as the bed nucleus of the stria terminalis (BNsT) also showed a strong diminished c-Fos induction in phyto0 treated mice. Significant deficit was observed in the medial preoptic area MPOA (G, H) with phyto0 diet.

BMA: basomedial amygdala, cc: corpus callosum, LV: lateral ventricle, ac: anterior commissure. Scale bar, 300 $\mu$ m. (I) Density of c-Fos positive profiles in different brain regions of phyto150 and phyto0 diet treated mice. Microscopic images were recorded in grayscale and inverted for better illustration of labeling. All values are mean $\pm$ SEM:

\*  $p < 0.05$ ; \*\*  $p < 0.01$ ; \*\*\*  $p < 0.001$  compared to phyto150 diet.

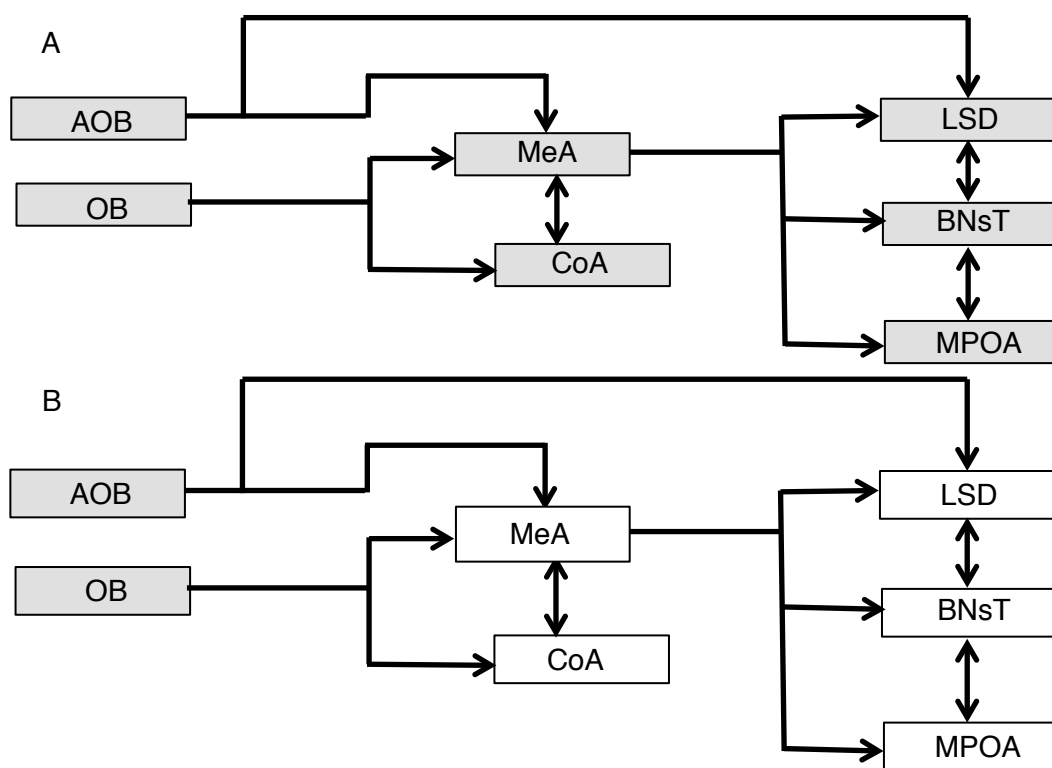

**Fig. 50.** Neuroanatomical areas analyzed for c-Fos expression after social encounter between the groups. This schematic diagram showing the circuit associated with the input and processing of various brain regions associated with social interaction. The diagram shows an overall activation of different brain regions in phyto150 (A) and phyto0 (B) diet. The grey boxes indicate the activation is similar to the control phyto150 mice. The white boxes indicate reduction in c-Fos activation in comparison to control mice.

#### **5.4. Discussion:**

In this chapter, I observed reduced sociability and disturbance of intermale aggression in C57Bl/6 male mice on phyto0 diet. These changes have been associated with reduction of sensitivity for odors association and weak activation of c-Fos induction in the brain circuit controlling social behavior on phyto0 diet. Thus suggesting phytoestrogens might be critical in the regulation of social interaction.

In my study design I treated adult male mice with two phytoestrogens diet conditions, one containing phytoestrogens (phyto150 with 150 mg of daidzein and genistein) and another deficient in phytoestrogens (phyto0). The data from the two diets revealed a profound disturbance in both social preference and intermale aggression during behavioral analysis. Although, I also observed altered urine mark patterns in male mice treated with phytoestrogens free diet. Thus suggesting a possible association of phytoestrogens with the modulation of social behavior.

I have limited my behavioral test to male mice though there exist an extensive research material in establishing the function of estrogens and females in social interaction (Choleris et al., 2006; Clipperton-Allen et al., 2012). In my study, I was interested to address the possible function of estrogens with social interaction in a system less likely to be effected by internal estrogens synthesis. Additional studies have shown differential involvement of the estrogen receptors with the male behavior (Krezel et al., 2001; Kudwa et al., 2005; Ogawa et al., 1998; Wersinger et al., 1997)

Most of the studies related to hormone modulation are designed with either vasectomy or oophorectomy (Sorwell et al., 2008). But studies have shown that there is an increase in the levels of corticosterone post vasectomy (Jacobsen et al., 2012). Therefore, my study was designed using a non-invasive approach of diet administration to study the role of phytoestrogens in social behavior. Additionally, most of the studies related to phytoestrogens require chronic administration through diet then an acute administration (Cornwell et al., 2004; Ososki and Kennelly, 2003; Ranich et al., 2001). Hence keeping in mind I administered phytoestrogens containing phyto150 diet to the test animals for 6 weeks after attaining adulthood.

Estrogens are known to modulate number of social behaviors related to social interaction, recognition, mating and aggression (Choleris et al., 2003; Cushing et al., 2008; Finkelstein et

al., 1997; Hall et al., 2005; Murakami et al., 2011). Studies have shown association of the social behavior being mediated by estrogens at molecular levels (Choleris et al., 2003; Tang et al., 2005). Phytoestrogens, a plant source of soy and analogous to estrogens have been widely used to replace estrogen intake (Gibaldi, 2000; Osoki and Kennelly, 2003). There is an increase in trend for phytoestrogens intake as a showing viable alternative to estrogens therapy (Gibaldi, 2000; Osoki and Kennelly, 2003). Hence phytoestrogens has been gaining great interest for research associated with estrogens function.

Earlier studies with estrogens have shown phytoestrogens to interfere with the normal sexual behavior in both male and female rodents (Decatanzaro et al., 2013, Kudwa et al., 2007). Additional studies have shown modulation of social interaction in male mice via the differential distribution of the estrogens receptor in different brain regions (Murakami et al., 2011). In my study I observed a similar effect with reduction in preference for social stimuli in phyto0 treated mice on comparison to the control mice. Additionally there was an overall aversion towards the female either when offered a choice between the non social vs. social odor, male vs. female odor or male vs. female interaction partner in mice on phyto0 compared to phyto150 diet treated male mice. Further emphasis the probability of phytoestrogen in the regulation of social behavioral outcome.

Phytoestrogens consumption has been associated with altered behavior and especially linked to elevated aggression both in hamster and red colobus monkey (Wasserman et al., 2012). Hence in my study I obtained a similar effect with aggressive behavior observed with the phytoestrogens diet and ablation on phytoestrogens deficit diet. In the resident-intruder aggression paradigm the phyto150 treated male mice displayed aggressive attack whereas a reduction in aggression behavior i.e., attacks were either reduced or delayed in the phyto0 treated male mice. Aggressive behavior has been associated with pheromone identification (Chamero et al., 2007). Studies have shown how alteration of genes associated with pheromone identification or pheromone recognition result in sex identification and aggression deficit (Leypold et al., 2002; Stowers et al., 2002; Tolokh et al., 2013). Interestingly, the increase in anogenital sniffing by the phyto0 mice further underlined a possible deficit in the odor assessment by the phyto0 treated mice. Estrogens have been also associated with the regulation of urine marking behavior in mice (Wu et al., 2009). As previously discussed mice on phyto0 diet failed to display dominant behavior or aggressive behavior towards the intruder mice in the aggression test paradigm. Study has shown an association of estrogens with regulation of aggression and urine marking in mice (Wu et al., 2009). Urine marking is a good measure to

evaluate social dominance in male mice (Dirckamer et al., 2001). The data from the urine marking showed mice on phytoestrogens display less urine markings in the dominant center area compared to the control mice. Therefore suggesting role of phytoestrogens in the modulation of dominance male behavior in male mice. Furthermore olfactory dysfunction has been associated with impairment in nest building (Zarrow et al., 1971), deficits in aggression and urine marking (Clancy et al., 1984; Maruniak et al., 1986). The data showed no change in the complexity of nest building behavior between the two diets. Whereas, a significant change was observed in aggression and urine marking on phyto0 diet, suggest a possible role of phytoestrogen with olfactory function.

To further validate deficit for odor assessment, altered urine marking pattern and the ablation of aggressive behavior maybe due to the deficit in the odor recognition by the mice. I carried out an odor sensitivity test with series of odor dilutions i.e., both with non social and social odor. The odor test showed that there was an overall reduction in the odor assessment in the non social odor preference and suggesting a deficits in odor perception lower odor concentration with phyto0 diet. Whereas, the phyto0 treated mice displayed an aversive behavior towards the female pheromone especially at the highest concentration. Therefore, supporting the role of phytoestrogens in the modulation of olfactory function associated with social behavior.

Estrogens receptors are known to be differentially distributed and regulate different aspects of social behaviors in rodents (Clipperton-Allen et al., 2012; Cushing et al., 2008; Cushing and Wynne-Edwards, 2006). Studies show role of estrogens receptors in modulation of different cognitive and sexual behavior in rodents (Cushing et al., 2008; Krezel et al., 2001; Kudwa et al., 2005; Ogawa et al., 1998; Wersinger et al., 1997). Human studies have shown a sensitive response to odorant compounds and its mediated activation of the intercellular estrogens cascade (Pick et al., 2009). Study has shown regulation of the mRNA expression of the estrogens receptor in the medial amygdala in response to-social interaction with male mice (Murakami et al., 2011). Hence to address the circuitry involved in the altered behavior of phyto0 treated mice, I studied c-Fos induction by social interaction stimulation in several brain regions involved with pheromone detection and mediation of social interaction (Ferguson et al., 2001; Richter et al., 2005). No change of c-Fos induction was observed in the main olfactory bulb or the accessory olfactory bulb in the phyto0 treated mice after the social choice test. In contrast, reduced c-Fos induction was evident in the medial amygdala, cortical amygdala and

extensively in the bed nucleus of the stria terminalis, medial preoptic and the lateral septum of the phyto0 treated diet male mice.

Medial amygdala is critical in male mice for the regulation of different social behaviors like aggression and social preference (Murakami et al., 2011; Wang et al., 2013). It is the key target for the estrogens mediated social interaction studies (Cushing et al., 2008; Newman, 1999). Both cortical amygdala and medial amygdala are the two input center for the olfactory information from the main and accessory olfactory bulb, associated with social interaction and social recognition (Cooke et al., 1998; Coolen and Wood, 1998; Ferguson et al., 2001; Richter et al., 2005). The c-Fos cell quantification showed a marked deficit in the activation of the cells in response to social interaction in mice on phyto0 compared to phyto150 treated male mice. This suggests the deficit in c-Fos activation of the neurons by output information from the olfactory input may be one of the possible causes of the social deficit.

The output from the medial amygdala is implicated to identify conspecific pheromones and processing of the information both during sexual and non-sexual social behavior (Meredith and Westberry, 2004; Pereno et al., 2011). Medial amygdala is known to be closely in communication with the bed nucleus of the stria terminalis, lateral septum and the medial preoptic area during social stimulation (Been and Petrusis, 2011; Coolen and Wood, 1998). Studies have shown a reduction of the estrogens receptor in the bed nucleus of the stria terminalis to mediate social behavior (Lei et al., 2010). The overall reduction in the c-Fos induction in the bed nucleus, lateral septum and the medial preoptic area suggest a weak stimulation from medial amygdala to the downstream regions associated with the processing of the social information. Hence suggesting an overall weak activation of the regions associated with the information processing in context to social interaction. Thus suggesting a probability of phytoestrogens in regulation of social behavior at neuronal network level.

Recent studies have shown estrogens to be associated with the regulation of the circadian activity (Nakamura et al., 2008, Rossetti et al., 2011). Additionally, the supra chiasmatic nuclei (SCN) associated with circadian orchestration are known to express both types of estrogen receptors (Kruijver and Swaab, 2002; Vida et al., 2008). Therefore I investigated for a possible role of phytoestrogens in circadian regulation in male mice. The data showed an hour delay during the shift between the dark-light phases. Thus underlining the functional role of phytoestrogen in the regulation of the phase shift in the C57Bl/6 male mice.

Phytoestrogens are known to bind to the estrogen receptor to mediate down stream cascade and they mediate this by exerting their effects through changes in endogenous  $17\beta$ -estradiol or testosterone levels. However, serum concentration of these steroids remained unaffected between the different phytoestrogens diets. Weber et al., (2001) reported an effect of dietary phytoestrogens on testosterone levels in Swiss male mice, however, the dose used in the previous study was about four times as high as here. Thus the effects of dietary phytoestrogens in my study may have been due to a direct action on the brain. Most (>95 %) of soy phytoestrogens in the rodent brain is metabolized to equol (Lephart et al., 2001), which at the plasma concentration achieved during soy-rich diets effectively stimulates  $\beta$ -estrogen receptors. Chronic nutrition with phytoestrogens leads to an equol accumulation in the amygdala and frontal cortex, but not the hippocampus (Lund et al., 2001), and thus may well alter the activation state of amygdala estrogen receptors. It has been shown in rats that continuous nutrition with a phyto600 diet leads to significant accumulation of phytoestrogens in the amygdala (73ng/g total phytoestrogens as compared to 25ng/g on a phyto-free diet (Lund et al., 2001)).

Data from social interaction and aggressive behavior showed deficits in mice treated with phyto0 diet compared to the phyto150 diet. Vasopressin and oxytocin had been shown to interact with estrogen in mediating social behavior (Murakami et al., 2011). Vasopressin has been associated with male territorial marking, aggressive behavior, anxiety and social recognition (Everts and Koolhaas, 1997; Honig et al., 1987; Le Moal et al., 1987; Winslow et al., 1993). Different vasopressin receptors had been associated in mediation of male social behavior (Keverne and Curley, 2004). Estradiol is known to mediate direct effect on the release of the vasopressin from the neurons (Sompanpun and Sladek, 2002). The low levels of phytoestrogen administered to the mice fail to induce any change in the vasopressin levels in the blood serum between the two diets. The possible explanation would be the low levels of phytoestrogens administered to the mice to mediate any change in vasopressin serum levels in the two conditions.

Therefore, it is highly plausible that phytoestrogens is one of the factors mediating social behavior in male mice. Social behavior impairment is one of the hallmarks of psychiatric disorders like schizophrenia, bipolar disorders and autism. Furthermore phyto0 treated mice showed odor deficits with reduced sensitivity and increased anogenital sniffing. Interestingly human studies have shown odor deficits to be associated with the early onset of psychosis

(Corcoran et al., 2005). There is evidence of a correlation of the negative symptoms of schizophrenia with rate of odor deficit in men (Ochoa et al., 2012) Most of these disorders are known to be dimorphic at sexual gender level (Gilles and McArthur, 2010; Mendrek and Stip, 2011). Study shows a high incidence of the psychiatric disorders in women during menopause (Colenda et al., 2010). Neuroprotective nature of the estrogens has been suggested as one of the reasons for high prevalence of the psychiatric disorder at an early time point compared to women (Fiocchetti et al., 2012). Thus suggesting phytoestrogens can be a possible cure for the treatment of different psychosis.

In this study I observed phytoestrogens deficient state to mimic social behavior deficits as observed in GAD67 haplodeficit male mice. GABA is one of the estrogens sensitive inhibitory neurotransmitter (Wagner et al., 2001). Estrogens are known to regulate ligand binding to the GABA(A) receptor. They differentially modulate the GABA(A) receptors in different brain regions, which are based on the ratio of estrogens receptors in that brain region (Majewska, 1992; Paul and Purdy, 1992) Both *in vivo* and *in vitro* studies have shown the localization of the estrogenic receptors in the GABAergic neurons (Blurton and Tuszynski, 2002; Hart et al., 2001; Wagner et al., 2001). Studies have shown a differential mediation of GABA function by estrogens (Canonaco et al., 1993; Maggie and Perez, 1986; O'Connor et al., 1988). Estrogens treatment was shown to significantly increase the GABA(A) receptor subunit mRNA by 30-60% both in the medial preoptic area and bed nucleus of stria terminalis (Herbison and Fenelon, 1995). Medial preoptic area is one of the important regions for the regulation of the male reproduction and identification of volatile female odors (Powers et al., 1987) and BNsT is associated with opposite sex odor identification (Been and Petrulis, 2011). Lesion of the medial preoptic area results in impaired mating and male sexual behavior (Powers et al., 1987). Phytoestrogens are known to regulate circulatory estrogens and neurosteroids. It is plausible that the reduction of estrogens with phytoestrogens may interfere with the normal function of estrogens receptors in the MPOA and BNsT and thus interferes with modulation of GABA. Lane et al., (2009) showed chronic administration of benzodiazepine (GABAergic stimulant) influenced social interaction in a dose dependent manner.

Study showed regulation of the GAD expression both at the transcriptional and translation level by estrogen (McCarthy et al., 2004). They are known to directly mediate GAD65 and 67 mRNA expressions in different subregions of the brain (Joh et al., 2006; McCarthy et al., 2004). In the next chapter I will try to understand the role of phytoestrogens with GAD expression.

Chapter 3

**Phytoestrogen mediated modulation of Glutamic acid decarboxylase (GAD) gene expression in the amygdala.**



### **6.1. Introduction**

$\gamma$ -aminobutyric acid (GABA), is the key inhibitory neurotransmitter critical for brain regulation. Clinical studies have shown that changes in the GABA levels might contribute to anxiety disorders in humans (Goddard et al., 2001; 2004). Nuclear imaging techniques have shown reduction in central GABA receptor levels in patients suffering from anxiety disorders like post-traumatic stress disorder, generalized anxiety disorder and panic disorder (Goddard et al., 2004; Roy-Byrne et al., 1996). Earlier work have shown individual with low GABA plasma levels during the time of trauma are more vulnerable to develop acute post-traumatic stress disorder than other victims (Valva et al., 2004). The link between the changed GABAergic transmission and anxiety disorders is also supported by the fact that patients suffering from anxiety disorders are commonly treated with benzodiazepine (Heldt et al., 2012).

Amygdala is critical for it contributes to different behavior symptoms associated with anxiety disorders and fear response. In mammals, the amygdala is rich in GABA(A) receptors, which is critical for fear and anxiety behavior (McDonald et al., 2004; Mueller et al., 2007). Pharmacological alteration of GABA in the amygdala in animal models are being used to study anxiety related phenotype (Green et al., 1992; Pesold et al., 1995). Therefore both behavioral and physiological lines of evidence suggest that GABAergic transmission in the amygdala is critical for the regulation of anxiety and fear. One such example is reduction in the GABA levels in the amygdala to tone fear conditioning. Similarly the reduction of the GABA synthesizing enzyme GAD65 is known to be reduced in the amygdala 24 h after fear conditioning (Stork et al., 2002). GAD67 also has been associated with the anxiety related behavior and fear memory (Heldt et al., 2012). Thus suggesting both the GAD isozymes are critical for the regulation of a normal response to fear and anxiety.

Most of the emotional behaviors are regulated by amygdala through the gonadal hormone estrogens. The different emotional behaviors: mood fluctuation, depression, irritation and anxiety have often been linked with low levels of estradiol (Genazzani et al., 1999). The estrogen receptors are known

densely distributed in the amygdala (Shughrue et al., 1999). Estrogens like amygdala and GABA are also involved with fear and anxiety regulation via the basolateral amygdala. They are known to behave differently because estrogens in the basolateral amygdala reduced the neuronal excitability (Edwards et al., 1999) to fear response. Though there is limited information about the function of the estrogen in amygdala to fear response but it is plausible that GABA is involved in the mechanism. Estrogens are known to directly regulate GAD65 and GAD67 mRNA expression in different subregions of the brain including the amygdala (Murphy et al, 1998; Noriega et al, 2010; Weiland, 1992). Thus ample evidence suggests that GAD may be a key target of these steroid analogs. Henceforth suggesting estrogens to be critical for the modulation of the GABAergic function. GABAergic tone in the amygdala can be affected by serotonergic signaling, which can be down-regulated by the interaction of the estradiol with the serotonin receptors (Gross et al., 2000). These receptors are known to be associated with pathological state like depression and anxiety disorders (Krezel et al., 2000). Thus further emphasizing the role of estrogens in amygdala and related behavior modulation. As mentioned earlier amygdala is the point of convergence for both GABA and estrogens mediated behaviors and function. Therefore I quantified the GAD67 activity in the GAD67-GFP mice treated with two different phytoestrogen diet conditions (phyto0 and 150). Furthermore, I quantified the GAD isozymes expressions in the different subregions of the amygdala. Amygdala is the key center for the regulation of the different emotional behaviors. Therefore I even assess the role of phytoestrogens in the modulation of different emotional states.

## 6.2. Experimental design

**Table 5.1:** Here I tabulated the different test I used to address the role of phytoestrogens in GAD expression in different subregions of the amygdala. The detailed description of the methods for reference has been mentioned in the method section (page 24-59).

| <b>Test</b>                                   | <b>Test type</b>  |
|---|---|
| <b>GFP quantification</b>                     | Subregion level GFP quantification (N=6 Phyto150; 6 Phyto0 treated mice).   |
|   | Cell level GFP quantification (N=6 Phyto150; 6 Phyto0 treated mice).  |
| <b>RNA quantification in the brain tissue</b> | GAD65, GAD67, NPY and SST quantification in different subregions of the amygdala (N=6 Phyto150; 6 Phyto0 treated mice). |
| <b>Anxiety measurements</b>                   | Open field test (N=38 Phyto150; 22 Phyto0 treated mice).  |
|   | Light and dark avoidance test (N=9 Phyto150; 9 Phyto0 treated mice).  |
| <b>Fear memory measurement</b>                | Neutral context (N=6 Phyto150; 6 Phyto0 treated mice).  |
|   | Shock context (N=6 Phyto150; 6 Phyto0 treated mice).  |

Animals used during the test were naïve.

### Statistical analysis:

Statistical analysis was done with Students's t test for pairwise comparison of the groups and one sample t test was carried out for the quantitative PCR gene expression. MANOVA and Chi ( $\chi^2$ ) square test was done as appropriate.

### 6.3. Results

#### 6.3.1. Increased GFP expression in different subregions of amygdala in GAD67-GFP mice on phyto150 diet compared to phyto0 diet.

To investigate the regulation of GAD67 activity in different subregions of the amygdala by phytoestrogen, GAD67-GFP mice a knock-in mutation with a GFP insert downstream of the GAD67 promoter, was used for GABAergic functional assessment by the phytoestrogen (Tamamaki et al., 2003). The GFP emission was used as a tool to quantify the functional activity of the GAD67 promoter upstream of the GFP gene and its response to different phytoestrogen diet (Fig. 51.).

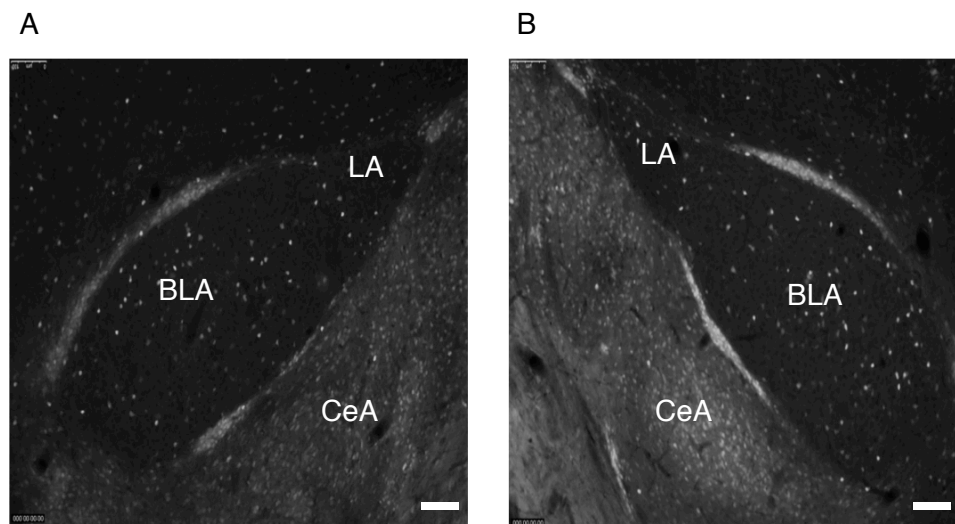

**Fig. 51.** GAD67-GFP emission quantification: GFP fluorescence in the amygdala of phyto0 (A) and phyto150 (B) treated mice reveal the expected interneuron-like expression pattern. The comparison showed reduction in the GFP emission in different subregions with phyto0 versus phyto150 treatment. Scale bar, 100  $\mu$ m. (LA: Lateral amygdala, BLA: Basolateral amygdala, CeA: Central nuclei amygdala).

Initially the total GFP emission per area of the different subregions of the amygdala: lateral, basolateral and central amygdala on the two diets was measured. The data analysis showed a significant increase in the GFP emission per total area on the phyto150 diet compared to the phyto0 diet both in lateral (GAD67-GFP:

phyto0=720.7±27.9 GFP emission density; phyto150 =879.1±114.0 GFP emission density;  $t(9)=2.3$ ,  $p<0.05$ ) (mean±SEM) and basolateral amygdala (GAD67-GFP: phyto0= 737.4±38.1 GFP emission density; phyto150 = 916.3±136.3 GFP emission density ; Student's t test:  $t(9)=2.3$ ,  $p<0.05$ ; Fig. 52). Whereas no change in the GFP expression was observed in the central nuclei of the amygdala between the two diets (GAD67-GFP: phyto0= 1561.9±33.8 GFP emission; phyto150 = 1589.7±132.9 GFP emission;  $t(9)=0.3$ , n.s.; Fig. 52).

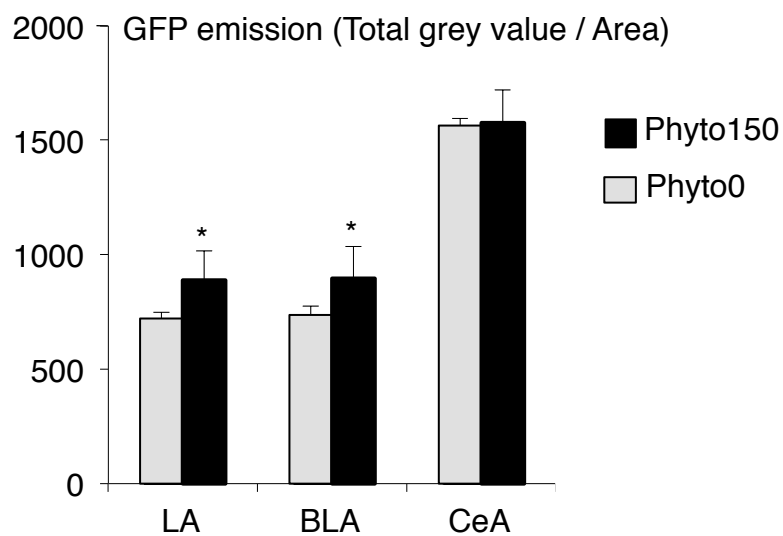

**Fig. 52.** Quantification of signal intensity in different amygdala subregions shows increase of GFP in the LA and BLA upon phyto150 diet. CeA showed high levels in both groups. All values are mean±SEM: \*  $p < 0.05$ .

To further validate if the change observed in the total area with GFP emission on diet is being constant even at the individual cell level. GFP intensity was measured in random individuals cells ( $n=30$ ) per amygdala subregions. The cell GFP quantification measurements were limited only to lateral and basolateral amygdala regions. Central amygdala quantification was omitted because cells in that region are densely packed, making it difficult to quantify. Additionally no significant change was observed in GFP emission within this region on the two diets. Analysis of the GFP emission at the individual cell per area showed an overall increase in the GFP

emission per cell per area both in the lateral ( $\chi^2$ ;  $p < 0.001$ ) and basolateral amygdala ( $\chi^2$ ;  $p < 0.01$ ) (Fig 53. A, B).

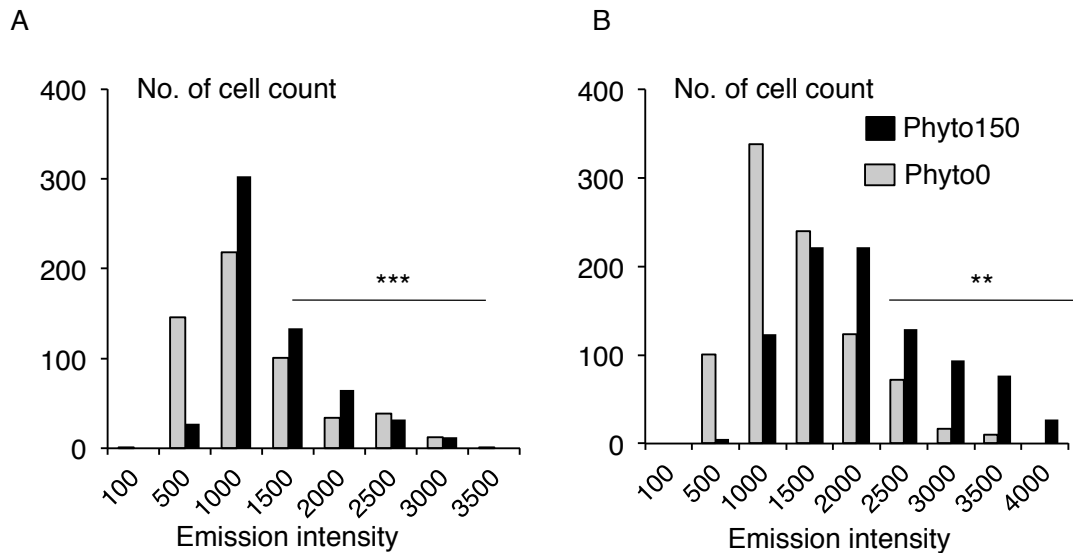

**Fig. 53.** GFP single cell quantification in the lateral (A) and basolateral (B) quantification revealed an increase in the proportion of intensity and a reduction of weakly GFP labeled cells, indicating activation of the GAD67 gene in a large proportion of interneurons in both regions. LA, lateral amygdala, BLA, basolateral amygdala. All values showed are in are mean $\pm$ SEM: \*\*\* $p < 0.001$ , \*\* $p < 0.01$ .

### 6.3.2. Altered mRNA expression in different subregions of the amygdala with the two diets.

To determine the molecular association of phytoestrogens treatment with GAD, I used high-resolution microdissection technique to determine the overall mRNA expression of GAD isoforms in different subregions of the amygdala. The total mRNA expression values were normalized to housekeeping gene PGK (Phosphoglycerate kinase). GAD67 mRNA expression profile from different subregions of the amygdala on phyto150 diet showed a significant increase both in basolateral amygdala (BLA) (phyto0= 0.2 $\pm$ 0.1 RQ (relative quantity) vs. phyto150= 1.23 $\pm$ 1.6 RQ; Student's one sample t-test;  $t(10)=1.8$ ,  $p < 0.05$ ) and lateral amygdala (LA) compared to phyto0 diet (phyto0= 0.3 $\pm$ 0.1 RQ vs. phyto150= 2.7 $\pm$ 2.6 RQ;

$t(10)=1.3$ , n.s.; Fig 54 B). To further validate if the effect is limited only to GAD67 or other genes expression was also effected with phytoestrogen diet treatment.

Interestingly, similar trend was observed for GAD65 expression with an overall increase in different subregions of the amygdala. GAD65 showed a significant increase in expression especially in the basolateral amygdala with the phyto150 diet (BLA: phyto0=  $0.2\pm 0.2$  RQ vs. phyto150= $0.9\pm 0.8$  RQ;  $t(10)=1.9$ ,  $p<0.01$ ; LA: phyto0 =  $1.3\pm 1.5$  RQ vs. phyto150= $2.5\pm 2.2$  RQ,  $t(10)=1.0$ , n.s.; Fig. 54 A).

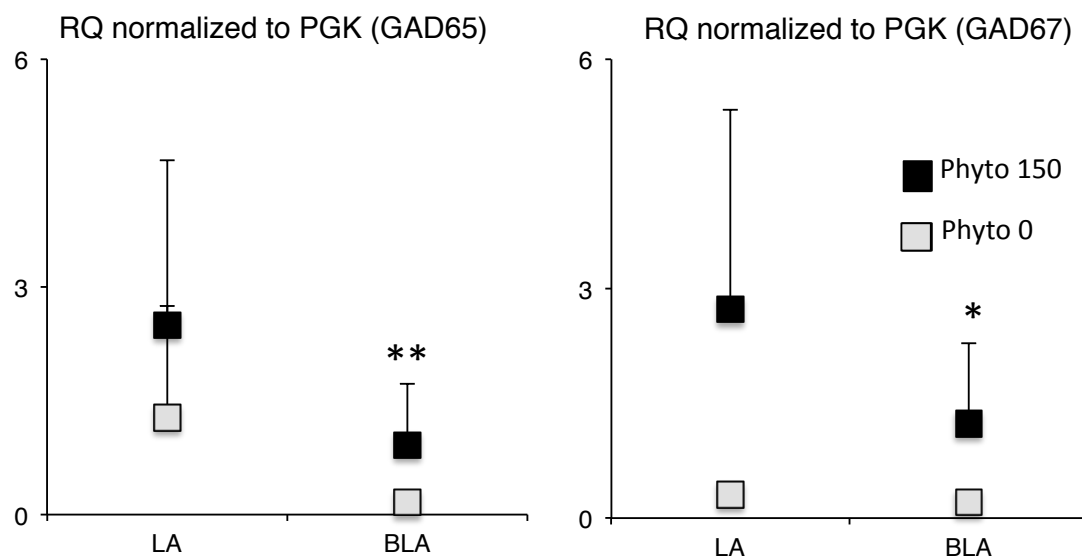
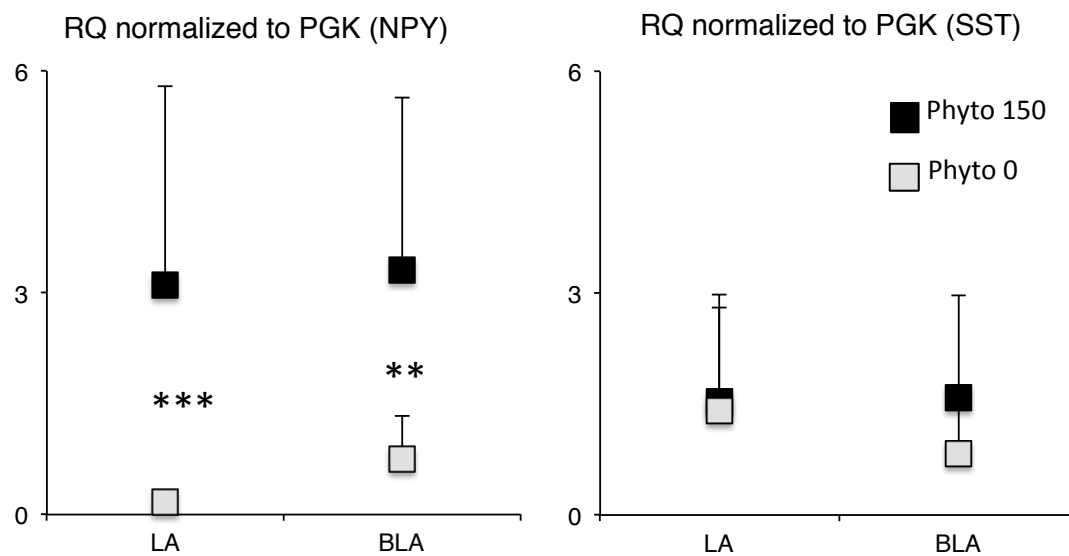

**Fig. 54.** Relative mRNA expression of GAD67 and GAD65 levels in different subregions of the amygdala. GAD65 expression showed an overall increase with phyto150 diet especially in BLA and LA (A) and a similar increase in overall expression was observed with GAD67 in BLA and LA (B). All values are mean $\pm$ SEM: \*\* $p < 0.01$ , \*  $p < 0.05$ .

Estrogen has been associated with the regulation of neuropeptides (Sar et al., 1990; Zengin et al., 2013). Studies have shown interaction of GABAergic interneurons in the amygdala and NPY (Mueller et al., 2007; Parker et al., 1998).

Hence to investigate does phytoestrogens diet mediates effect on the expression of the neuropeptides like neuropeptide Y (NPY) or somatostatin (SST). Interestingly,

the mRNA expression in the different subregions of the amygdala showed a significant increase in NPY expression on phyto150 diet compared to phyto0 diet both in lateral (phyto0=0.2±0.1 RQ vs. phyto150=3.1±2.7 RQ;  $t(10)=2.5$ ,  $p<0.001$ ; Fig. 55 A) and basolateral amygdala (phyto0=0.8±0.6 RQ vs. phyto150=3.8±3.0 RQ;  $t(10)=2.04$ ,  $p<0.01$ ; Fig. 55, A). Whereas, no significant change was observed with the two diet treatment on SST mRNA expression in different subregions of the amygdala (lateral amygdala: phyto0=1.4±1.6 RQ vs. phyto150=1.5±1.3 RQ;  $t(10)=0.1$ , n.s.; basolateral amygdala: phyto0=0.8±0.7 RQ vs. phyto150=1.6±0.8 RQ;  $t(10)=1.4$ , n.s.; Fig. 55 B).



**Fig. 55.** Relative mRNA expression of NPY and SST levels observed in different subregions of the amygdala. NPY expression showed an overall increase in expression with phyto150 diet especially in BLA and LA (A). No significant increase in SST expression was observed with phyto diet treatment. All values are mean±SEM: \*\*\* $p < 0.001$ , \*\* $p < 0.01$ .

#### 6.3.4 Anxiolytic effect mediated by the phytoestrogens on male mice

Earlier studies have shown phytoestrogens induce anxiolytic effect in rats at higher dosage (Weber et al., 2001). To quantify the anxiolytic effect of the phytoestrogens I measured anxiety with two diet groups both in open field and light-dark avoidance test.



In open field test no change in total distance was observed between the phytoestrogen diet, Student's unpaired t test (phyto0=82.2±9.1 m, phyto150=83.5±8.1 m,  $t(56)=0.5$ , n.s.; Fig. 56 A). Animal showed an increase in time spend in the center arena (phyto0=12.5±4.1 %, phyto150=15.6±13.0 %,  $t(56)=2.1$ ,  $p<0.05$ ; Fig. 56. C) of the open field and a significant increase in entries in the center field. (phyto0=16.2±2.9 %, phyto150=18.6±2.7 %,  $t(56)=2.4$ ,  $p<0.05$ ; Fig. 56. B)

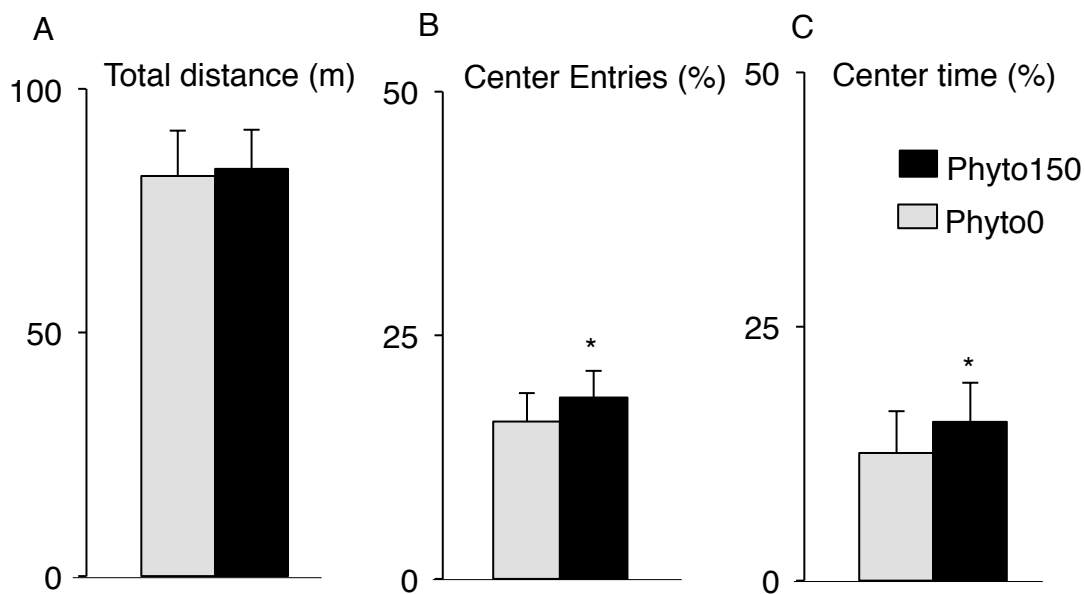

**Fig. 56.** Open field test: Total distance covered by the test mice during the open field test remained unchanged between the two diets (A). There was a significant increase in the center entries % (B) and center time (%) with phyto150 compared to phyto0 diet. All values are mean±SEM: \*  $p < 0.05$ .

Although in the light-dark avoidance test no change was observed in the total distance covered (phyto0=6940.6±448.3 cm vs. phyto150=6157.1±1174.9 cm  $t(15)=1.5$ , n.s.; Fig. 57 A) or the total activity measured (phyto0=82.2±2.5 % vs. phyto150=80.5±4.3 %;  $t(15)=0.8$ , n.s.; Fig. 57 B). The mice on phyto0 treated diet spend more time in the light compartment compared to the phyto150 treated mice (Phyto0=99.8±10.8 s vs. Phyto150=85.1±10.7 s;  $t(15)=2.3$ ,  $p<0.05$ ).

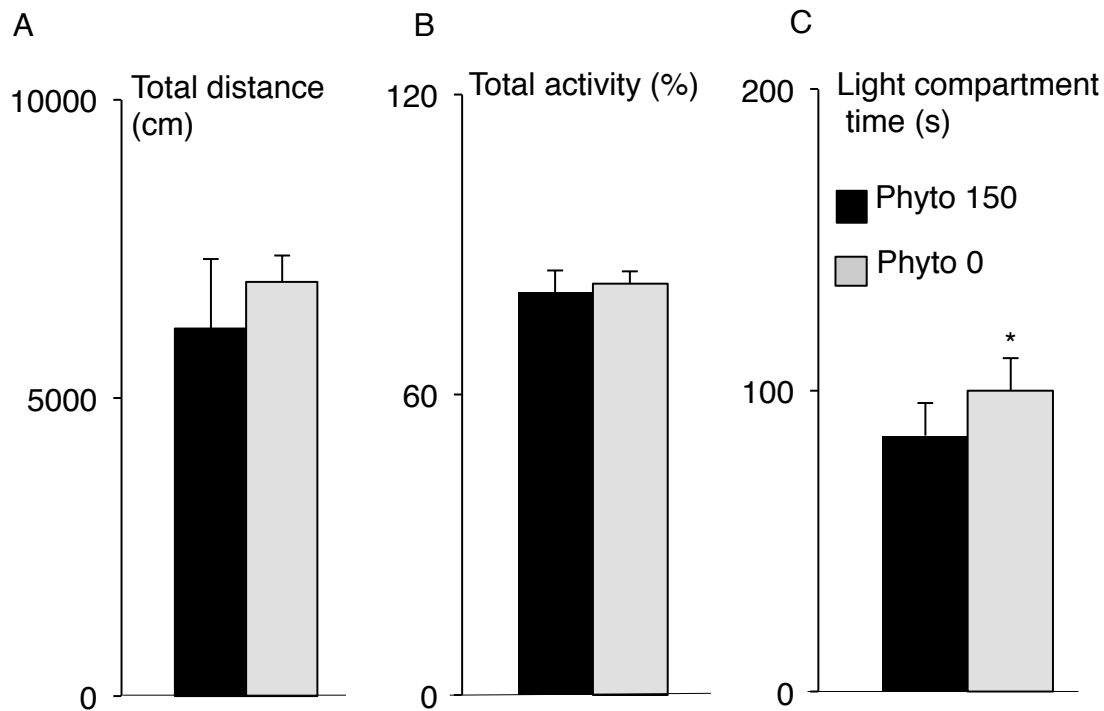

**Fig. 57.** Anxiety measure in the light-dark avoidance test: Anxiety values measured between the two dietary treatment with total distance (A), total activity (B) and time spend in the light compartment (C). All values are mean±SEM: \*\*\* $p < 0.001$ , \*\* $p < 0.01$ , \*  $p < 0.05$ .

### 6.3.3. Reduction in overall freezing and increase in hyperactive response was observed in shock context of Pavlovian fear memory paradigm with phyto0 diet.

Most of the studies to address the function of GAD and GABA have been with the Pavlovian fear paradigm. Previous observed molecular data from GFP quantification and GAD mRNA expression analysis in the amygdala showed an overall regulation of the GAD67 and 65 in the basolateral amygdala on the phyto150 diet. Thus to determine if there is any correlation between the changed molecular expression observed in the amygdala and its preceding behavior profiling.

Here I investigate do phytoestrogens mediate any change in the fear memory paradigm. The hyperactivity measurements showed an overall difference in response between the two context offered with phyto0 diet: shock context (SC) ANOVA (Ctxt:  $F(1,16)=27.9$ ,  $p<0.0001$ ; US:  $F(1,16)=12.3$ ,  $p<0.01$ ; CS:  $F(1,16)=3.2$ ,

$p=0.095$ ; Fig. 58 A, a). Hyperactive response was displayed only by phyto0 mice in the shock context (SC) compared to phyto150 mice (Student's unpaired t test, Fig 58. A; SC: Ctxt phyto0= $1.8\pm 0.8$  %, phyto150= $0.9\pm 0.3$  %,  $t(15)=2.1$ ,  $p=0.55$ ; US: phyto0= $11.3\pm 7.3$  %, phyto150= $2.6\pm 1.7$  %,  $t(15)=2.8$ ,  $p<0.05$ ; CS: phyto0= $11.3\pm 6.1$  %, phyto150= $2.1\pm 1.3$  %,  $t(15)=3.6$ ,  $p<0.01$ ).

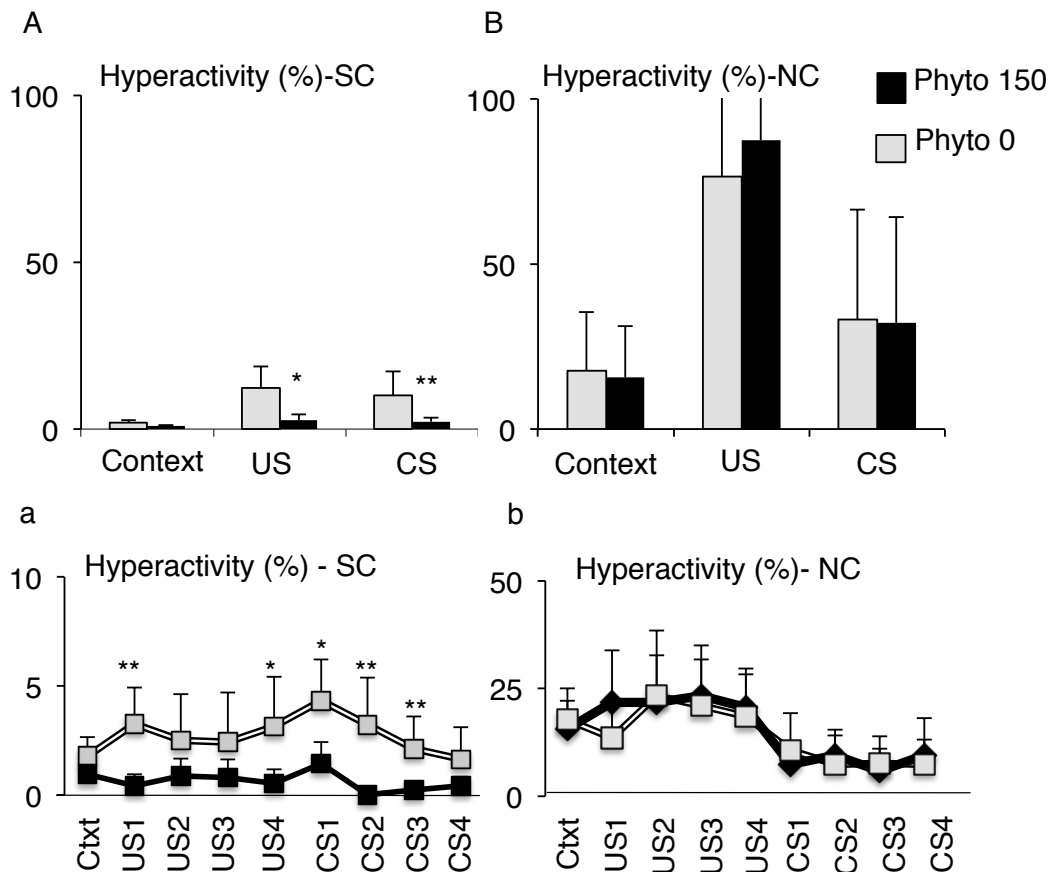
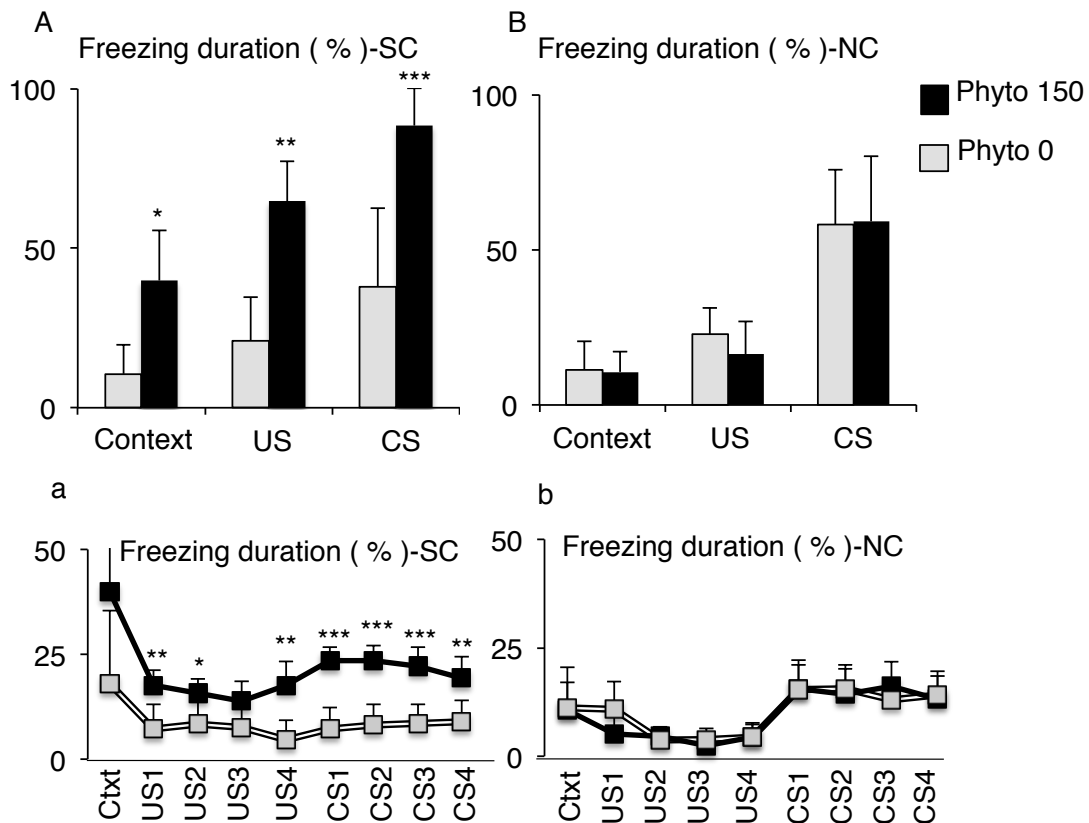

**Fig. 58.** Increased hyperactivity with phyto0 diet treated mice and its attenuation with phyto150 diet. Phyto0 treated mice showed an increased hyperactive response during the retrieval session in shock context (SC) compared to phyto150 diet treated mice (A, a). No effect of either diet was observed in hyperactivity measure during retrieval session in the neutral context (NC) (B, b). All values are mean $\pm$ SEM: \*\* $p < 0.01$ , \*  $p < 0.05$ .

To further validate do phytoestrogen diet mediate any effect on the hyperactive behavior in the neutral context also. Hyperactive measure in the neutral context (NC) (Fig 58 B; NC: Ctxt phyto0= $17.8\pm 7.3$  %, phyto150= $15.5\pm 6.7$  %,  $t(15)=0.5$ , n.s.; US phyto0= $76.3\pm 41.1$  %, phyto150= $87.3\pm 39.1$  %,  $t(15)=0.1$ , n.s.; CS phyto0= $33.2\pm 24.6$

%, phyto150=32.1±24.4 %, t(15)=0.5, n.s.). No change in the hyperactive measure was observed in the neutral context.

Earlier studies show an increase in flight and escape response in GAD deficit mice and reduction in the freezing response (Stork et al., 2003). Hence for further validation if the increase in the hyperactivity (flight-fight response) may result in generalization of fear in phyto0 treated mice. Male C57Bl/6 mice on phyto0 diet showed a significant reduction in the response to the conditioned stimuli between the shock (SC) and neutral context (NC) ANOVA (NC vs. SC: Ctxt: F(1,15)=0.55, p=0.47; US: F(1,15)=0.23, n.s.; CS: F(1,15)=5.57, p<0.05;). Interestingly, there was a significant increase in the freezing response with phyto150 diet treatment compared to the phyto0 diet treatment in the shock context (SC) Student's unpaired t test (Fig. 59 A; SC: Ctxt: phyto0=16.8±16.3 %, phyto150=39.8±15.6 %, t(16)=2.4, p<0.05; US: phyto0=27.4±19.9 %, phyto150=64.8±12.4 %, t(16)=3.6, p<0.01; CS: phyto0=39.0±22.7 %, phyto150=88.4±11.8 %, t(16)=4.7, p<0.0001). Whereas no change in the freezing levels were observed between the diet treatment in the neutral context (NC) (Fig. 59 B; NC: Ctxt: phyto0=11.3±9.3 %, phyto150=10.7±6.4 %, t(15)=0.2, n.s.; US: phyto0=22.8±8.5 %, phyto150=16.4%±10.6, t(15)=0.9, n.s. ; CS: phyto0=58.1±17.6 %, phyto150=59.2±20.9 %, t(15)=0.1, n.s.).



**Fig. 59.** Overall reduction in the freezing response by the phyto0 mice was observed in the shock context (SC). Phyto0 mice showed attenuation in freezing response in the shock context during retrieval session compared to the phyto150 mice (A, a). The freezing levels were normal between the two diets in the neutral context (NC) (B, b). All values are mean±SEM: \*\*\* $p < 0.01$ , \*\* $p < 0.01$ , \*  $p < 0.05$ .

A dissected version of the overall freezing response over the different stimuli in the shock context showed a significant reduction in the freezing response is limited to the shock context compared to the neutral context and the rescue of this freezing deficit by the phyto150 diet treatment (Fig. 59 a, b).

To further validate if there is any additive effect with GAD67 and 65 in the freezing response with the two dietary treatments in the shock context. GAD67<sup>+/-</sup> male mice on both diet treatment showed no change in either of the retrieval stimuli: shock context (SC: Ctxt: phyto0=31.2±18.6 %, phyto150=29.6±12.3 %,  $t(17)=2.0$ ,  $p=0.06$ ;

US phyto0=37.1±14.3 %, phyto150=58.6±22.7 %, t(17)=0.2, p<0.01; CS phyto0=72.3±22.2 %, phyto150=77.3±15.7 %, t(17)=0.4, n.s.). Similarly, no change in the freezing response was observed with GAD65<sup>+/-</sup> mice with the two diets: shock context (SC: Ctxt: phyto0=43±15.7 %, phyto150=45.3±28.1 %, t(24)=0.4, n.s.; US phyto0=38.3±12.9 %, phyto150=35.3±19.8 %, t(24)=0.3, n.s.; CS: phyto0=42.9±13.1 %, phyto150=53.9±20.6 %, t(24)=1.2, n.s.).

Thus suggesting that phytoestrogen diet induce a context mediated effect in the fear memory paradigm.

#### **6.4.0 Discussion**

In the previous chapter I have shown modulation of the social behavior by phytoestrogen chronic administration to male mice. However the social behavior displayed by the phytoestrogen mimicked social and aggressive behavior observed in GAD67 phenotype. It is plausible that phytoestrogen may play a role in GAD expression or function.

GABA and GAD have been associated with various functions such as: anxiety and memory response (Heldt et al., 2010; Lydiard, 2003; Makkar et al., 2012; Stork et al., 2003). In this study I have shown deficits in GAD67 and 65 expression in the basolateral amygdala with phytoestrogen deficit in diet and resulting in an altered response in the fear memory paradigm with an increase in anxiety levels. Thus suggesting phytoestrogen as a means to ameliorate the deficit. Moreover I further strengthen my finding of the plausible role of phytoestrogen with GAD activity especially in the amygdala. These observations further identify GAD as a target for the regulation of environment mediated gene interaction and its function in controlling emotional memory. Therefore, my study further underlined the therapeutic aspect of phytoestrogens as a treatment to relief behavioral deficit related to altered GAD67 expression.

Amygdala is very critical in context to fear memory consolidation and anxiety (Agren et al., 2012; Nader et al., 2000; Shin and Lierzon, 2010). Both the afferent and efferent projections in the amygdala are important for the expression and acquisition of fear (Davis, 2000; LeDoux, 2000). Studies have shown changes in the levels of the circulating estrogens to be linked to alter emotional response and result in the onset of mental illness especially in females (Arpels, 1996; Sherwin, 1998; Sichel et al., 1995). It is well established that both estrogen receptors genes are widely expressed throughout the amygdala in both rodents and humans (Jasnow et al., 2005; Merchenthaler et al., 2004; Osterlund et al., 1998, 2000). Human subject study with bilaterally damaged amygdala showed impaired fear recognition (Adolps et al., 2005). Numerous studies have shown altered levels of GABAergic transmission or GAD to contribute to behavioral symptoms associated with anxiety or fear memory consolidation (Klausberger et al., 2005; McDonald and Mascagni, 2004; Mueller et al., 2007). Therefore, for the initial screening I used GAD67-GFP

mice as a model to analysis the effect of phytoestrogen on GAD67 gene activity. Increase in GFP labelling was observed both in LA and BLA, thus suggesting GAD67 gene activation by phyto150 diet. In contrast GFP labelling was generally higher in CeA compared to the LA and BLA, potentially due to high saturation effect of close-nit cells in this region. For a more detailed quantification I carried out single cell GFP quantification in both the LA and BLA subregions of the amygdala. The GFP data showed an overall shift towards an enhanced intensity in the BLA and an overall increase in the LA. Hence suggesting the role of phytoestrogen in the GAD67 activity. To further validate whether phytoestrogen mediated gene regulation is also evident at the transcriptional level and also to determine whether the regulation is limited only to GAD67 expression. Therefore, I carried out micro-dissection with a laser capture of tissues from different subregions of the amygdala. Then carried out a quantitative PCR to quantify the GAD65 and 67 mRNA expression in the different subregions of the amygdala. I found that dietary phytoestrogens increase GAD67 and 65 mRNA expression across the amygdala subnuclei of C57Bl/6 mice, supporting the view that phytoestrogens are potent activators of GAD gene in amygdala. The diet showed a significant effect in a region specific manner especially in the BLA with both GAD67 and 65 gene expression. Estrogens are known to be closely linked with the regulation of the neuropeptides (Sar et al., 1990). It has been shown that the NPY and SST are co-localization to the GABAergic interneurons in the amygdala (Parker, 1998; Muller et al., 2007). Consequently I investigated the function of phytoestrogen with neuropeptide expression in the different subregions of the amygdala. The output data from the mRNA expression from different subregions showed an overall increase in the NPY expression both in the lateral and basolateral amygdala with phytoestrogen administration. Whereas, no change was observed in SST expression between the subregions with the two diets. Thus suggesting phytoestrogen directly or indirectly through GAD function may have a role to play in the NPY expression in lateral and basolateral amygdala.

As previously discussed amygdala is associated with the regulation of anxiety. Previously I have shown how phytoestrogens regulate GAD65 and 67 expression in the basolateral amygdala. Additionally, clinical evidence suggests change in the GABA and GAD levels to contribute in mediation of anxiety related disorders (Heldt et al., 2012). Studies have shown patients suffering from anxiety disorders are often



treated with benzodiazepine (Roy-Byrne et al., 1996, 1999; Vaiva et al., 2004). Studies suggest, NPY to be anxiolytic in function both in humans and animals (Heiling et al., 1998). On the other hand studies have shown phytoestrogens to be anxiolytic in function (Weber et al., 2001). Recent work by Heldt et al., show the mediation of anxiolytic behavior in mice by the GAD67 expression in the amygdala (Heldt et al., 2012). The GFP and the mRNA quantification showed basolateral amygdala to be sensitive to both phytoestrogen mediated changes and study showing GABAergic interneurons in the basolateral amygdala to modulate anxiety related behavior (Truitt et al., 2009). Thus suggesting the regulation of the GAD67 and NPY expression by the phytoestrogen in the amygdala and mediating anxiolytic behavior. Therefore to further address the anxiolytic function of phytoestrogen I measured anxiety both in open field and light and dark compartment. The output data showed an increase in the center entries and time spent by the mice with phytoestrogen treated diet compared to the phytoestrogen free diet. Thus supporting the anxiolytic function of the phytoestrogens. Whereas mice on the phytoestrogen free diet showed more activity in the light compartment than phytoestrogen treated mice during light-dark test measure. Thus contradicting the anxiolytic activity observed with the phytoestrogen diet in the open field. The contrasting output for the two anxiety parameters could be due to low levels of phytoestrogen failing to attain a strong anxiolytic effect in different anxiety measure paradigm. Heredia et al., (2014) showed C57Bl/6 strain are less responsive to various anxiolytic drugs in various anxiety measure and this may answer the contrasting anxiety behavior, I measured in open field and light-dark compartment.

Human studies have shown patients with anxiety disorders to be highly sensitive to fear response (Cuthbert et al., 2003). It has been shown both anxiety and fear memory are known to close linked (Maldonado et al., 2014). Henceforth I measured the behavioral response in phytoestrogen treated male mice in the fear conditioning paradigm. GABAergic inhibition is critical for the differentiation of the fear memory phases in the amygdala (Makkar et al., 2010). Reduction of both GAD67 and 65 expression upon fear conditioning and an increase of GAD67 following fear memory extinction have been reported (Heldt and Ressler, 2007; Rodriguez et al., 2005; Stork et al., 2002). Earlier studies carried out by our group have shown exaggerated conditioned fear response, generalization of fear memory and failure of extinction in

the GAD65 deficit mice (Bergado-Acosta et al., 2008; Sangha et al., 2009; Stork et al., 2003). Interestingly, I observed similar deficit with the generalization and exaggeration of the fear response with increase in hyperactivity in the shock context with phytoestrogen free diet. Similar response was also observed with increase hyperactive behavior during training with normal freezing. Thus supporting the function of the phytoestrogen in the fear memory response in relations to the context. Secondly, the effect with phytoestrogens was only limited to the C57Bl/6 mice and not in other transgenic mice. Underlying the sensitivity of the effect and also it again resurfaces the question of a possible protective effect during reduced GAD 67 or 65 levels. Additionally, the cell GFP quantification data and the mRNA expression data showed a significant effect in a region specific manner especially in the BLA with both GAD67 and 65 gene expression. Thus suggesting that the recovery of fear memory deficit observed in phyto0 diet through phyto150 diet treatment that results in an increase in GAD67/65 expression. Considering the suppression of the GAD67 and 65 expression during the formation and extinction of fear memory, it appears genetically or experience-dependent reduction of GAD67 or 65 mRNA in the amygdala effectively intervene with normal aversive conditioning (Bergado-Acosta et al., 2008; Heldt et al., 2012; Ressler et al., 2007). Functional consequences of enhanced GAD mRNA expression, in contrast, may only become evident under specific training conditions. For example, considering the homeostatic regulation of GAD protein levels (Spitzer et al., 2005), enhanced expression during extinction training (Ressler et al., 2007) may sub-serve as a buffering function towards acute fluctuations and thereby prevent memory reconsolidation. GABA functions in the amygdala may be subject to a multi-level regulation of GAD on the transcriptional, translational and post-translational level (Martin and Rimval, 1993; Wei and Wu, 2008).

Thus the data suggest that major differences exist between different subregions of amygdala and that deficit in the BLA particularly influence the aversive memory responses. Phytoestrogen are known to bind to the estrogen receptor to mediate down stream cascade and they mediate this by exerting their effects through changes in endogenous 17 $\beta$ -estradiol or testosterone levels.

However, alternative explanations should be considered: equol also binds to 5- $\alpha$  dihydrotestosterone, and thereby interferes with the function of androgen receptors

(Lund et al, 2004), which are prominently expressed in the amygdala (Cooke et al, 2003). Effects of phytoestrogens may further have been mediated by principle cell activity in the LA and BLA affecting GAD65/67 expression in interneurons via neural activity changes (Fritsch et al, 2009; Polepalli et al, 2010). Phytoestrogen-dependent increase in the 5 $\alpha$ -reductase in the amygdala (Lephart, 2001) could drive GAD expression via GABA $\alpha$ 1 receptors expressed on local interneurons. And finally, phytoestrogen effects on other regions, such as the anteroventral periventricular nucleus (Lepart et al, 2005), could modulate interneuron activity and activity-dependent gene expression in the LA and BLA.

The effect in the fear memory paradigm I observed were mostly contextual and ample data suggest towards the role of hippocampus to mediate contextual fear memory (Maren and Holt, 2000; Wiltgen, 2006). Numerous studies support the role of estrogen in the mediation of synaptic plasticity and function of the hippocampus (Fester et al., 2011; Foy et al., 2010). Studies show how the lesion of the hippocampus to invariably abolish contextual memory (Wiltgen, 2006). Lund et al., (2001) showed a significant accumulation of the phytoestrogens in the amygdala on phyto-600 diet compared to phyto-free diet, whereas no change was observed in context to the hippocampus. Studies have shown a significant increase in the dendritic spines in the hippocampus (CA1) with estrogen treatment (Woolley and McEwen, 1993). Thus suggesting estrogen to play a critical role in the regulation and function of hippocampus but nothing is known about the pathway mediating the phytoestrogen effecting hippocampal function. One suggestive pathway could be its interaction with neurosteroids, ample amount of literature support the role of neurosteroids to induce circuit modification of the hippocampus (Fester and Rune, 2014). Additionally, estradiol has been known to maintain LTP in females and not in males (Vierk et al., 2014). Henceforth, suggesting one needs to address and better understand the role of phytoestrogens in male in context to hippocampus.

## **7. Conclusion**

In the first chapter of my study GAD67-GFP mice were used to validate the phenotypic function of GAD67 in the modulation of social behavior. Social behavior dysfunction is one of the core symptoms associated with a number of psychiatric disorders with altered GABA and GAD67 expression (Coghlan et al., 2012; Gonzalez-Burgos et al., 2011; Guidotti et al., 2005). GAD67 haplodeficit mice showed a reduction in preference for the social stimuli in animal (male) vs. empty or male vs. female social interaction paradigm. Thus underlying the function role of GAD67 in the modulation of social behavior. Impaired social behavior has often been linked to olfactory function. In accordance to it, I validated the role of GAD67 in the olfactory assessment. Olfactory test data showed a reduction in the overall preference for social odor when offered (non social odor vs. male bedding or non social odor vs. female bedding). Thus suggesting a general deficit in social odor association. . This raised point was further validated when the GAD67 haplodeficit mice showed poor preference for female to male odor. Thus suggesting a deficit in the olfactory system in the GAD67 deficit mice impairing social deficit and olfactory assessment. This was further formalized when the GAD67 haplodeficit mice failed to identify the odor (social (female pheromone) and non social odor) offered at lower dilutions compared to the control mice. The olfactory dysfunction was also well supported when the GAD67 haplodeficit mice failed to display any aggressive behavior towards the intruder in the resident intruder paradigm. Thus concluding the mediation of GAD67 in the regulation of social and aggressive behavior. Interestingly c-Fos, an immediate early gene, used to observe the activation of the brain regions associated with social interaction (animal (male) vs. empty) showed similar deficit in neuron activation in MeA, CoA, BNsT, LSD and MPOA. Substantiating, a deficit in the input from the olfactory system resulting in the total inactivation of the processing regions required for the social interaction function. Apart from addressing the role of GAD67 in the social behavior, I also found its association in the regulation of biological activity. GABA has been associated with a number of psychiatric disorders with disturbance in the circadian pattern (Han et al., 2012). These disorders have often been reported with altered

GAD67 levels. Here too I validated that GAD67 haplodeficit mice showed a two hour delay in the activity compared to the wildtype mice. This delay is more evident during the shift between the dark and light phases. Another reason could be deficit of GAD67 in the medial preoptic area of GAD67 haplodeficit mice. Thus concluding functional role of GAD67 in social behavior and homeostasis of the biological activity.

Secondly, after the validation of the GAD67 mediated phenotypic behavior I addressed the function of the phytoestrogens on the C57Bl/6 mice. I compared the data I collected from the GAD67 phenotypic assessment, to the phytoestrogen-free diet condition to validate if both conditions display a similar trend. Social interaction test showed a similar impairment in the social preference on phytoestrogen-free diet in the social paradigm with animal (male) vs. empty and female vs. male. It is likely phytoestrogens could have some role in the regulation of GAD67 or could modulate the social interaction network that might involve GAD67. I further showed mice treated with phytoestrogen-free diet induce similar deficit in the olfactory assessment between non social male and non social female odor. Interestingly, the deficit in the odor preference was observed to be more significant and stronger when the female odor was offered compared to the male odor. Similar deficit was also observed when male and female bedding was offered to the phytoestrogen-free mice. These phytoestrogen-free treated mice showed reduced preference for the female compared to the phytoestrogens mice. Thus underlying role of phytoestrogens in mediation of social behavior and olfactory assessment. Earlier during the GAD67 haplodeficit mice phenotype evaluation, I observed ablation in aggression in the resident intruder paradigm. In my study with effects of phytoestrogens I tried to address if it is possible to mimic the same. Interestingly, I managed to mimic it. Phytoestrogen-free animals showed latency and some failed to attack the intruder mice. Additionally, these mice showed an increase in anogenital sniffing compared to the phytoestrogens treated mice. Thus suggesting an impaired olfactory system induced by the phytoestrogen-deficit condition. The above findings cumulated together suggest a possible link between the GAD67 function and regulation of phytoestrogens on GAD67 expression. GAD67 as shown earlier was linked to homeostasis of the biological activity. A

delay of 2 hours was observed in mice with GAD67 deficiency, similar inclination with delay of 1 hour was observed during the phase shift between the two active phases on the phytoestrogen-free diet. Thus further emphasising the point phytoestrogens has an effect on the GAD67 function.

GABA has been associated with fear memory consolidation. Therefore, in the third chapter I further underlined the role of phytoestrogens in the mediation of GAD67/65 expression in fear memory consolidation. Amygdala as discussed earlier in the introduction and also known to be critically associated with GABA mediated fear memory formation. Estrogens receptors are expressed in the different subregions of amygdala (Cao and Patisaul, 2013; Krezel et al., 2001). Therefore, I quantified the GFP in the GAD67-GFP mice to validate GAD67-GFP activity on the different dietary treatment. Both the regional and high resolution cell GFP quantification showed an overall regulation of the GFP with the diet i.e., increase in GFP expression in LA and BLA region on phytoestrogens diet and similar trend in the increase in cell number with high GFP emission on phytoestrogens diet and vice versa. Thus supporting my early finding, that phytoestrogens do play a role in the regulation of GAD67 activity. The GFP quantification only gave us the reading of the GAD67 promoter activity. Then the question was what happens at the molecular level. For a molecular quantification I carried out micro-dissection of different subregions of the amygdala to further validate if the effect is true even at mRNA level. The real time quantification showed an overall increase with phytoestrogens treatment in the GAD67 and 65 expressions in different subregions of the amygdala. Strikingly, there was a significant increase in expression of both the GAD isoforms in the basolateral amygdala with phytoestrogens compared to phytoestrogen-free diet. Additionally the estrogens are known to modulate the expression of neuropeptides (McDonald and Pearson, 1989). Studies have shown neuropeptide Y (NPY) to be co-localized in the GABAergic neurons in the amygdala (Difourny and Warembourg, 1999). The real time data showed a marked increase in the NPY expression in the different subregions of the amygdala on the phytoestrogens diet. Interestingly, the change of expression by phytoestrogens on the neuropeptides expression was limited to NPY, whereas no change was observed in the somatostatin expression.

Basolateral amygdala is known to be one of the critical points with fear memory because of high expression of the GABA(A) receptor expression (Makkar et al., 2012). In accordance to that the next question I addressed was the role of phytoestrogens in fear memory conditioning. Interestingly, the mice showed reduction in the overall freezing in the shock context during the retrieval, correlating to the hyperactive behavior displayed by phytoestrogen-free diet treated mice. Secondly, most critical finding was the effect that was limited to the shock-context as the effect was not observed in the neutral-context. Thus suggesting the role of the phytoestrogens in the regulation of the GAD67 and 65 mediated fear memory consolidation through the amygdala function. The overall reduction in freezing response is limited to the shock context, does suggest role of hippocampus as its critical for the regulation of the contextual memory. Many studies support a link between estrogens and hippocampus both in neuroplasticity and memory formation (Bean et al., 2014; Foy et al., 2008). It is plausible the altered response to the fear stimuli in shock context is due to the role of phytoestrogen on the hippocampus but this needs to be addressed further in near future.

Therefore, culminating together my study validated the point quite strongly that phytoestrogens do modulate GAD, both GAD67 and 65. The effect is not just limited to the molecular expression but low and chronic dosage of phytoestrogen can induce strong phenotypic profile effect in C57Bl/6 male mice.

## **8. Future direction**

Phytoestrogens have been long associated with estrogen therapy, cancer research and stroke rehabilitation (Castello-Ruiz et al., 2011; Lin et al., 2005; Patisaul and Jefferson, 2010; Rice and Whitehead, 2006). Despite of that limited information existed about its function and mechanism.

In my study I addressed the role of phytoestrogens in GAD67 mediated behavior, but still one can investigate the interaction at molecular level. The data would be interesting to address the effect of phytoestrogens as direct or indirect and possible interacting partners. My study addressed the short-term effect with 6 week of phytoestrogens depletion. It would be apt to address the long-term effects of phytoestrogens in association with aging and gender. I administrated the mice lower dosage of phytoestrogens i.e., 150 mg, resulting in no significant change in the blood serum estradiol level. It would be interesting to study the effects of higher dosage of phytoestrogens as used in earlier studies by Lepart et al., (2006). My findings have been limited only to C57Bl/6 strains but there are other strains such as FVB/N widely being used for estrogen related studies (Geisler et al., 2002; Raafat et al., 2012; Zhang et al., 2004). Therefore, one may try to investigate the differential anxiolytic effect of phytoestrogens between different strains.

Limited information is known about the mechanism underlying social interaction, a core symptoms associated with various psychiatric conditions. Nevertheless, I addressed the plausible role of GAD67 and phytoestrogens in the modulation of social behavior. With the application of drugs like imidazole or application of GAD67 expressing vector virus injection in the social behavior brain regions such as medial amygdala. One can aim to restore the normal social interaction state and further dissect the core area associated with the social deficit. Here in my study I limited my work to male mice because I was interested in the function of gene and diet-gene interaction correlated with social behavior. However one may also look into role of phytoestrogen with GAD in female mice because estrogen is one



of the critical gonadal hormones regulating social behavior in females (Choleris et al., 2006; Clipperton-Allen et al., 2012).

Studies have shown that most of the neurons in the olfactory bulb are GABAergic in origin (Kohwi et al., 2007; Vergaño-Vera et al., 2006). However no change was observed in activation of the accessory or the main olfactory region by c-Fos with the social stimuli between the genotype or diet condition. Nonetheless the weak activation of the medial amygdala could be due to the weak input from the olfactory system. Therefore one may use mutant mice with selective Cre driver expression in the granular layer or olfactory bulb (such as; CRE-driver in the mitral/tufted layer of the olfactory bulb (Nagai et al., 2005)) and mate them with Flox-GAD67 mice. The generated transgenic mice can be used to investigate the effect of olfactory function in social and olfactory behavior. My study is among the initial studies suggesting role of phytoestrogen and glutamic acid decarboxylase and also their corresponding part on social behavior modulation. I believe a lot new data and information in this direction will be of great value for better cure and alternative treatment for the psychiatric pathology.

## 9. Bibliography:

Addington A.M., Gornick M., Duckworth J., Sporn A., Gogtay N., Bobb A., Greenstein D., Lenane M.N., Gochman P. and Baker N. (2005) GAD1 (2q31.1), which encodes glutamic acid decarboxylase (GAD67), is associated with childhood-onset schizophrenia and cortical gray matter volume loss. *Mol Psychiatry*. 10: 581-588.

Adlercreutz H. (1995) Phytoestrogens: epidemiology and a possible role in cancer protection. *Environ Health Perspect*. 103: 103-112.

Adlercreutz H., Fotsis T., Kurzer M.S., Wähälä K., Mäkelä T. and Hase T. (1995) Isotope dilution gas chromatographic-mass spectrometric method for the determination of unconjugated lignans and isoflavonoids in human feces, with preliminary results in omnivorous and vegetarian women. *Anal Biochem*. 225:101-108.

Adolphs R., Gosselin F., Buchanan T.W., Tranel D., Schyns P. and Damasio A.R. (2005) A mechanism for impaired fear recognition after amygdala damage. *Nature*. 433: 68-72.

Agren T., Engman J., Frick A., Björkstrand J., Larsson E.M., Furmark T. and Fredrikson M. (2012) Disruption of reconsolidation erases a fear memory trace in the human amygdala. *Science*. 337: 1550-1552.

Akbarian S., Kim J.J., Potkin S.G., Hagman J.O., Tafazzoli A., Bunney W.E. Jr and Jones E.G. (1995) Gene expression for glutamic acid decarboxylase is reduced without loss of neurons in prefrontal cortex of schizophrenics. *Arch Gen Psychiatry*. 52: 258 – 266.

Albrecht A. and Stork O. (2012) Are NCAM deficient mice an animal model for schizophrenia? *Front. Behav Neurosci*. 6: 43.

Almeida O.P., Lautenschlager N., Vasikaram S., Leedman P. and Flicker L. (2005) Association between physiological serum concentration of estrogen and the mental health of community-dwelling postmenopausal women age 70 years and over. *Am J Geriatr Psychiatry*. 13: 142-149.

- Amin Z., Canli T. and Epperson C.N. (2005) Effect of estrogen-serotonin interactions on mood and cognition. *Behav Cogn Neurosci Rev.* 4: 43-58.
- Ammassari-Teule M., Pavone F., Castellano C. and McGaugh J.L. (1991) Amygdala and dorsal hippocampus lesions block the effects of GABAergic drugs on memory storage. *Brain Res.* 551: 104-109.
- Arpels J.C. (1996) The female brain hypoestrogenic continuum from the premenstrual syndrome to menopause. A hypothesis and review of supporting data. *J Reprod Med.* 41:633-9.
- Arrati P.G., Carmona C., Dominguez G., Beyer C. and Rosenblatt J.S. (2006) GABA receptor agonists in the medial preoptic area and maternal behavior in lactating rats. *Physiol Behav.* 87: 51-65.
- Asada H., Kawamura Y., Maruyama K., Kume H., Ding R., Ju F.Y., Kanbara N., Kuzume H., Sanbo M., Yagi T. and Obata K. (1996) Mice Lacking the 65 kDa Isoform of Glutamic Acid Decarboxylase (GAD65) Maintain Normal Levels of GAD67 and GABA in Their Brains but Are Susceptible to Seizures. *Biochem Biophys Res Comm.* 229: 891-895.
- Asada H., Kawamura Y., Maruyama K., Kume H., Ding R.G., Kanbara N., Kuzume H., Sanbo M., Yagi T. and Obata K. (1997) Cleft palate and decreased brain gamma-aminobutyric acid in mice lacking the 67-kDa isoform of glutamic acid decarboxylase. *Proc Natl Acad Sci. USA* 94: 6496-6499
- Asimiadou S., Bittigau P., Felderhoff-Mueser U., Manthey D., Sifringer M., Pesditschek S., Dzierko M., Kaindl A.M., Pytel M., Studniarczyk D., Mozrzymas J.W. and Ikonomidou C. (2005) Protection with estradiol in developmental models of apoptotic neurodegeneration. *Ann Neurol.* 58: 266-276.
- Atkinson C., Frankenfeld C.L. and Lampe J.W. (2005). Gut bacterial metabolism of the soy isoflavone daidzein: exploring the relevance to human health. *Exp Biol Med.* 230: 155–170.
- Azcoitia I., Sierra A., Veiga S., Honda S., Harada N. and Garcia-Segura L.M. (2001) Brain aromatase is neuroprotective. *J Neurobiol.* 47: 318-329.
- Baddeley A. (2010) Working memory. *Curr Biol.* 20: R136-R40.

- Baez S., Herrera E., Villarin L., Theil D., Gonzalez-Gadea M.L., Gomez P., Mosquera M., Huepe D., Strejilevich S., Viglicca N.S., Matthäus F., Decety J., Manes F. and Ibañez A.M. (2013) Contextual social cognition impairments in schizophrenia and bipolar disorder. *PLoS One*. 8: e57664.
- Banecka-Majkutewicz Z., Sawuła W., Kadziński L., Węgrzyn A. and Banecki B. (2012) Homocysteine, heat shock proteins, genistein and vitamins in ischemic stroke--pathogenic and therapeutic implications. *Acta Biochim Pol*. 59:495-499.
- Bang S.J. and Commons K.G. (2012) Forebrain GABAergic projections from the dorsal raphe nucleus identified by using GAD67-GFP knock-in mice. *J Comp Neurol*. 520: 4157-4167.
- Barkhem T., Carlsson B., Nilsson Y., Enmark E., Gustafsson J. and Nilsson S. (1998) Differential response of estrogen receptor alpha and estrogen receptor beta to partial estrogen agonists/antagonists. *Mol Pharmacol*. 54: 105-112.
- Barkley M.S. and Goldman B.D. (1997) A quantitative study of serum testosterone, sex accessory organ growth, and the development of intermale aggression in the mouse. *Horm. Behav*. 8: 208.
- Barnard E.A., Skolnick P., Olsen R.W., Mohler H., Sieghart W., Biggio G., Braestrup C., Bateson A.N. and Langer S.Z. (1998) International Union of Pharmacology. XV. Subtypes of gamma-aminobutyric acidA receptors: classification on the basis of subunit structure and receptor function. *Pharmacol Rev*. 50: 291–313.
- Barnett R., Maruff P., Purcell R., Wainwright K., Kyrios M., Brewer W. and Pantelis C. (1999) Impairment of olfactory identification in obsessive-compulsive disorder. *Psychol Med*. 29:1227-1233.
- Bean L.A., Ianov L. and Foster T.C. (2014) Estrogen receptors, the hippocampus, and memory. *Neuroscientist*. 20: 534-545.
- Beaumont M. and Maccaferri G. (2011) Is connexin36 critical for GABAergic hyper-synchronization in the hippocampus? *J Physiol*. 589: 1663-1680 .
- Behl C. (2002) Oestrogen as a neuroprotective hormone. *Nature neurosc. Review*. 3: 433-442

Benes F.M., Lim B., Matzilevich D., Walsh J.P., Subburaju S. and Minns M. (2007) Regulation of the GABA cell phenotype in hippocampus of schizophrenics and bipolars. *Proc Natl Acad Sci U S A.* 104: 10164-10169.

Bergado-Acosta J.R., Müller I., Richter-Levin G. and Stork O. (2014) The GABA-synthetic enzyme GAD65 controls circadian activation of conditioned fear pathways. *Behav Brain Res.* 1: 92-100.

Bergado-Acosta J.R., Sangha S., Narayana R.T., Obata K., Pape H.C. and Stork O. (2008). Critical role of the 65-kDa isoform of glutamic acid decarboxylase in consolidation and generalization of Pavlovian fear memory. *Learn Mem.* 15: 163-171.

Bergemann N., Mundt C., Parzer P., Pakrasi M., Eckstein-Mannsperger U., Haisch S., Salbach B., Klinga K., Runnebaum B. and Resch F. (2005) Estrogen as an adjuvant therapy to antipsychotics does not prevent relapse in women suffering from schizophrenia: results of a placebo-controlled double-blind study. *Schizophr Res.* 74: 125-134.

Berrettini W.H., Nurnberger Jr J.I., Hare T.A., Simmons-Alling S., Gershon E.S. and Post R.M. (1983) Reduced plasma and CSF gamma-aminobutyric acid in affective illness: effect of lithium carbonate. *Biol Psychiatry.* 18: 185–194.

Bettler B., Kaupmann K., Mosbacher J. and Gassmann M. (2004) Molecular structure and physiological functions of GABA(B) receptors. *Physiol Rev.* 84: 835-867.

Bishop J. and Simpkins J.W. (1994) Estradiol treatment increases viability of glioma and neuroblastoma cells in vitro. *Mol Cell Neurosci.* 5: 303-308.

Blatt G.J., Fitzgerald C.M., Guptill J.T., Booker A.B., Kemper T.L. and Bauman M.L. (2001) Density and distribution of hippocampal neurotransmitter receptors in autism: an autoradiographic study. *J Autism Dev Disord.* 31: 537-543.

Blurton-Jones M. and Tuszynski M.H. (2002) Estrogen receptor-beta colocalizes extensively with parvalbumin-labeled inhibitory neurons in the cortex, amygdala, basal forebrain, and hippocampal formation of intact and ovariectomized adult rats. *J Comp Neurol.* 452: 276-87.

Bonin R.P. and Orser B.A. (2008) GABA(A) receptor subtypes underlying general anesthesia. *Pharmacol Biochem Behav.* 90: 105-112.

- Bos N.P. and Mirmiran M. (1993) Effects of excitatory and inhibitory amino acids on neuronal discharges in the cultured suprachiasmatic nucleus. *Brain Res Bull.* 31: 67-72.
- Bourin M. and Hascoët M. (2003) The mouse light/dark box test. *Eur J Pharmacol.* 2463: 55-65.
- Bowery N.G., Bettler B., Froestl W., Gallagher J.P., Marshall F., Raiteri M. et al. (2002). International Union of PharmacologyXXXIII. Mammalian  $\gamma$ -aminobutyric acid B receptors: structure and function. *Pharmacol Rev* 54: 247–264.
- Brambilla P., Perez J., Barale F., Schettini G, and Soares J.C. (2003) GABAergic dysfunction in mood disorders. *Mol Psychiatry.* 8: 721-737.
- Brennan P.A. and Keverne E.B. (2004) Something in the air? New insights into mammalian pheromones. *Curr Biol.* 14: R81-89.
- Brewer W.J., Edwards J., Anderson V., Robinson T. and Pantelis C. (1996) Neuropsychological, olfactory, and hygiene deficits in men with negative symptom schizophrenia. *Biol Psychiatry.* 40: 1021-1031.
- Brewer W.J., Wood S.J., Pantelis C., Berger G.E., Copolov D.L. and McGorry P.D. (2007) Olfactory sensitivity through the course of psychosis: Relationships to olfactory identification, symptomatology and schizophrenia odor. *Psychiat Res.* 149: 97-104.
- Brielmaier J., McDonald C.G. and Smith R.F., 2012. Autism-relevant social abnormalities and cognitive deficits in engrailed-2 knockout mice. *PLoS One.* 7: e40914.
- Brinton R. (2001). Cellular and Molecular Mechanisms of estrogen regulation of memory function and neuroprotection against Alzheimer's disease: Recent insights and remaining challenges. *Learn Mem.* 8: 121-133.
- Brockington I.F., Kelly A., Hall P. and Deakin W. (1988) Premenstrual relapse of puerperal psychosis. *J.Affective Disord* 14: 287-92.
- Byers S.L., Wiles M.V., Dunn S.L. and Taft R.A. (2012) Mouse estrous cycle identification tool and images. *PLoS One.* 7: e35538.
- Campo C.G., Sinagra M., Verrier D., Manzoni O.J. and Chavis P. (2009) Reelin secreted by GABAergic neurons regulates glutamate receptor homeostasis. *PLoS One.* 4: e5505.

- Cannon T.D. (2005) The inheritance of intermediate phenotypes for schizophrenia. *Curr Opin Psychiatry*.18: 135–140.
- Canonaco M., Tavolaro R. and Maggi A. (1993) Steroid hormones and receptors of the GABAA supramolecular complex. II. Progesterone and estrogen inhibitory effects on the chloride ion channel receptor in different forebrain areas of the female rat. *Neuroendocrinology*. 57: 974-984.
- Canonaco M., Tavolaro R. and Maggi A. (1993) Steroid hormones and receptors of the GABA, molecular complex. *Neuroendocrinology* 57: 974-984.
- Cao J. and Patisaul H.B. (2013) Sex-specific expression of estrogen receptors  $\alpha$  and  $\beta$  and Kiss1 in the postnatal rat amygdala. *J Comp Neurol*. 521: 465-478.
- Castellano C. and McGaugh J.L. (1989) Retention enhancement with post-training picrotoxin: lack of state dependency. *Behav Neural Biol*. 51: 165-170.
- Castelló-Ruiz M., Torregrosa G., Burguete M.C., Salom J.B., Gil J.V., Miranda F.J., Jover-Mengual T., Marrachelli V.G. and Alborch E. (2011) Soy-derived phytoestrogens as preventive and acute neuroprotectors in experimental ischemic stroke: influence of rat strain. *Phytomedicine*. 18: 513-515.
- Chambers M.S., Atack J.R., Carling R.W., Collinson N., Cook S.M., Dawson G.R., Ferris P., Hobbs S.C., O'Connor D. and Marshall G. (2004) An orally bioavailable, functionally selective inverse agonist at the benzodiazepine site of GABA<sub>A</sub>  $\alpha_5$  receptors with cognition enhancing properties. *J. Med. Chem*. 47: 5829–5832.
- Chamero P., Marton T.F., Logan D.W., Flanagan K., Cruz J.R., Saghatelian A., Cravatt B.F. and Stowers L. (2007) Identification of protein pheromones that promote aggressive behaviour. *Nature*. 450: 899–902.
- Chan F.K., To K.F., Wu J.C., Yung M.Y., Leung W.K., Kwok T., Hui Y., Chan H.L., Chan C.S., Hui E., Woo J. and Sung J.J. (2002) Eradication of Helicobacter pylori and risk of peptic ulcers in patients starting long-term treatment with non-steroidal anti-inflammatory drugs: a randomised trial. *Lancet*. 359: 9-13.
- Chhatwal J.P., Myers K.M., Ressler K.J. and Davis M. (2005) Regulation of gephyrin and GABAA receptor binding within the amygdala after fear acquisition and extinction. *J Neurosci*. 25: 502-506.

Chhatwal J.P. and Ressler K.J. (2007) Modulation of fear and anxiety by the endogenous cannabinoid system. *CNS Spectr.* 12: 211-220.

Chavez C., Hollaus M., Scarr E., Pavey G., Gogos A. and van den Buuse M. (2010) The effect of estrogen on dopamine and serotonin receptor and transporter levels in the brain: an autoradiography study. *Brain Res.* 19: 51-59.

Choi JS., Chon M.W., Kang D.H., Jung M.H. and Kwon J.S. (2009) Gender difference in the prodromal symptoms of first-episode schizophrenia. *J Korean Med Sci.* 24:1083-1088.

Choleris E., Ogawa S., Kavaliers M., Gustafsson J.A., Korach K.S., Muglia L.J. and Pfaff D.W. (2006) Involvement of estrogen receptor alpha, beta and oxytocin in social discrimination: A detailed behavioral analysis with knockout female mice. *Genes Brain Behav.* 5: 528-539.

Christgau S., Aanstoot H.J., Schierbeck H., Begley K., Tullin S., Hejnaes K. and Baekkeskov S. (1992) Membrane anchoring of the autoantigen GAD65 to microvesicles in pancreatic beta-cells by palmitoylation in the NH<sub>2</sub>-terminal domain. *J Cell Biol.* 118: 309-320.

Christofolini D.M., Meloni V.A., Ramos M.A., Oliveira M.M., de Mello C.B., Pellegrino R., Takeno S.S. and Melaragno MI. (2012) Autistic disorder phenotype associated to a complex 15q intrachromosomal rearrangement. *Am J Med Genet B Neuropsychiatr Genet.* 159B: 823-828.

Clancy A.N., Coquelin A., Macrides F., Gorski R.A. and Noble E.P. (1984) Sexual behavior and aggression in male mice: involvement of the vomeronasal system. *J Neurosci.* 4: 2222-2229.

Clipperton-Allen A.E., Lee A.W., Reyes A., Devidze N., Phan D.W. and Chloeris E. (2012) Oxytocin, vasopressin and estrogen receptor gene expression in relation to social recognition in female mice. *Physiol Behav* 4: 915-924.

Coghlan S., Horder J., Inkster B., Mendez M.A., Murphy D.G. and Nutt D.J. (2012) GABA system dysfunction in autism and related disorders: from synapse to symptoms. *Neurosci Biobehav Rev.* 36: 2044-2055.



Collinson N., Kuenzi F.M., Jarolimek W., Maubach K.A., Cothliff R., Sur C., Smith A., Out, F.M., Howell, O., Atack, J.R. et al. (2002) Enhanced learning and memory and altered GABAergic synaptic transmission in mice lacking the  $\alpha_5$  subunit of the GABA<sub>A</sub> receptor. *J. Neurosci.* 22: 5572–5580.

Colenda C.C., Legault C., Rapp S.R., DeBon M.W., Hogan P., Wallace R., Hershey L., Ockene J., Whitmer R., Phillips L.S. and Sarto G.E. (2010) Psychiatric disorders and cognitive dysfunction among older, postmenopausal women: results from the Women's Health Initiative Memory Study. *Am J Geriatr Psychiatry.* 18: 177-186.

Connell B.J. and Saleh T.M. (2011) Differential Neuroprotection of Selective Estrogen Receptor Agonists against Autonomic Dysfunction and Ischemic Cell Death in Permanent versus Reperfusion Injury. *Adv Pharmacol Sci.*: 976951.

Cooke B., Hegstrom C.D., Villeneuve L.S. and Breedlove S.S. (1998) Sexual differentiation of the vertebrate brain: Principles and mechanisms. *Front Neuroendocrinol.* 19: 323-362.

Coolen L.M. and Wood R.I. (1998) Bidirectional connections of the medial amygdaloid nucleus in the Syrian hamster brain: simultaneous anterograde and retrograde tract tracing. *J Comp Neurol.* 399: 189-209.

Corcoran C., Whitaker A., Coleman E., Fried J., Feldman J., Goudsmit N. and Malaspina D. (2005) Olfactory deficits, cognition and negative symptoms in early onset psychosis. *Schizophr Res.* 80: 283-293.

Cornwell T., Cohick W. and Raskin I. (2004) Dietary phytoestrogens and health. *Phytochemistry.* 65: 995-1016.

Couture S.M., Penn D.L. and Roberts D.L. (2006) The functional significance of social cognition in schizophrenia: A review. *Schizophr. Bull.* 32: 44-63.

Craig M.C. and Murphy D.G. (2007) Estrogen: effects on normal brain function and neuropsychiatric disorders. *Climacteric.* 10: 97-104.

Crawley J.N., Chen T., Puri A., Washburn R., Sullivan T.L., Hill J.M., Young N.B., Nadler J.J., Moy S.S., Young L.J., Caldwell H.K. and Young W.S. (2007) Social approach behaviors in oxytocin knockout mice: comparison of two independent lines tested in different laboratory environments. *Neuropeptides.* 41: 145.

Crestani F., Keist R., Fritschy J.M., Benke D., Vogt K., Prut L., Bluethmann H., Mahler H. and Rudolph U. (2002) Trace fear conditioning involves hippocampal  $\alpha_5$  GABA<sub>A</sub> receptors. *Proc. Natl. Acad. Sci. U.S.A.* 99: 8980–8985.

Cryan J.F. and Slattery D.A. (2010) GABA(B) receptors and depression. Current status. *Adv Pharmacol.* 58: 427-451.

Curley A.A., Arion D., Volk D.W., Asafu-Adjei J.K., Sampson A.R., Fish K.N. and Lewis D.A. (2011) Cortical deficits of glutamic acid decarboxylase 67 expression in schizophrenia: clinical, protein, and cell type-specific features. *Am J Psychiatry.* 168: 921-929.

Cushing B.S. and Wynne-Edwards K.E. (2006) Estrogen receptor alpha distribution in male rodents is associated with social organization. *J Comp Neurol* 494: 595– 605.

Cuthbert B.N., Lang P.J., Strauss C., Drobos D., Patrick C.J. and Bradley M.M. (2003) The psychophysiology of anxiety disorder: fear memory imagery. *Psychophysiology* 40: 407-422.

Cutter W.J., Craig M., Norbury R., Robertson D.M., Whitehead M. and Murphy D.G. (2003) In vivo effects of estrogen on human brain. *Ann NY Acad Sci.* 1007: 79-88.

Cutter W.J., Norbury R. and Murphy D.G. (2003) Oestrogen, brain function, and neuropsychiatric disorders. *J Neurol Neurosurg Psychiatry.* 74: 837-840.

Cyr M., Calon F., Morissette M., and Di Paolo T. (2002) Estrogenic modulation of brain activity: implications for schizophrenia and Parkinson's disease. *J Psychiatry Neurosci.* 27: 12-27.

Danzer R., Bluthé R.M., Koob G.F. and Le-Moal M. (1988) Septal vasopressin modulates social memory in male rats. *Brain Res.* 457: 143-147.

Davis A.M., Grattan D.R., Selmanoff M. and McCarthy M.M. (1996) Sex differences in glutamic acid decarboxylase mRNA in neonatal rat brain: implications for sexual differentiation. *Horm Behav.* 30: 538-552.

Davis M. and Shi C. (2000) The amygdala. *Curr Biol.* 10: R131.

Day S. J., Holmes E.A. and Hackmann A. (2004) Occurrence of imagery and its link with early memories in agoraphobia. *Memory* 12: 416-427.

- Deacon R.M. 2006. Assessing nest building in mice. *Nat Protoc.* 1: 1117-1119.
- De Jeu M. and Pennartz C. (2002) Circadian modulation of GABA function in the rat suprachiasmatic nucleus: excitatory effects during the night phase. *J Neurophysiol.* 87: 834-844.
- DeLorey T.M., Sahbaie P., Hashemi E., Homanics G.E. and Clark J.D. (2008) Gabrb3 gene deficient mice exhibit impaired social and exploratory behaviors, deficits in non-selective attention and hypoplasia of cerebellar vermal lobules: a potential model of autism spectrum disorder,” *Behav Brain Res.*, 187: 207-220.
- Del Punta K., Leinders-Zufall T., Rodriguez I., Jukam D., Wysocki C.J., Ogawa S., Zufall F. and Mombaerts P. (2002) Deficient pheromone responses in mice lacking a cluster of vomeronasal receptor genes. *Nature* 419: 70-74.
- Dennerstein L., Judd F. and Davies B. (1983) Psychosis and the menstrual cycle. *Med J Aust* 1: 524-526.
- De Marco García N.V., Karayannis T. and Fishell G. (2011) Neuronal activity is required for the development of specific cortical interneuron subtypes. *Nature.* 472: 351-355.
- Dirkx R. Jr., Thomas A., Li L., Lernmark A., Sherwin R.S., De Camilli P. and Solimena M. (1995) Targeting of the 67-kDa isoform of glutamic acid decarboxylase to intracellular organelles is mediated by its interaction with the NH<sub>2</sub>-terminal region of the 65-kDa isoform of glutamic acid decarboxylase. *J Biol Chem.* 270: 2241-2246.
- Dong E., Agis-Balboa R.C., Simonini M.V., Grayson D.R., Costa E., Guidotti A. (2005) Reelin and glutamic acid decarboxylase67 promoter remodeling in an epigenetic methionine-induced mouse model of schizophrenia. *Proc. Natl. Acad. Sci. USA.* 102: 12578-12583.
- Drickamer L.C. (2001) Urine marking and social dominance in male house mice (*Mus musculus domesticus*). *Behav Processes.* 53: 113-120.
- Dufourny L. and Warembourg M. (1999) Estrogen modulation of neuropeptides: somatostatin, neurotensin and substance P, in the ventrolateral and arcuate nuclei of the female guinea pig. *Neurosci Res.* 33: 223-228.

- Dufourny L. and Warembourg M. (1999) Estrogen modulation of neuropeptides: somatostatin, neurotensin and substance P, in the ventrolateral and arcuate nuclei of the female guinea pig. *Neurosci Res.* 33: 223-228.
- Edwards H.E., Burnham W.M., Mendonca. A., Bowlby D.A., MacLusky N.J. (1999) Steroid hormones affect limbic afterdischarge thresholds and kindling rates in adult female rats. *Brain Res.* 838: 136-50.
- Ehlers A., and Clark D.M. (2000) A cognitive model of posttraumatic stress disorder. *Behav Res and Ther.* 38: 319-345.
- Erlander M.G., Tillakaratne N.J., Feldblum S., Patel N. and Tobin A.J. (1991) Two genes encode distinct glutamate decarboxylases. *Neuron.* 7: 91-100.
- Esclapez M., Tillakaratne N.J., Tobin A.J., Houser C.R. (1993) Comparative localization of mRNAs encoding two forms of glutamic acid decarboxylase with nonradioactive in situ hybridization methods. *J. Comp. Neurol.* 331: 339-62.
- Esclapez M, Tillakaratne N.J., Kaufman D.L., Tobin A.J. and Houser C.R. (1994) Comparative localization of two forms of glutamic acid decarboxylase and their mRNAs in rat brain supports the concept of functional differences between forms. *J Neurosci.* 14: 1834–1855.
- Everts H.G. and Koolhaas J.M. (1997) Lateral septal vasopressin in rats: role in social and object recognition? *Brain Res.* 760: 1-7.
- Falls W.A., Miserendino M.J.D. and Davis M. (1992) Extinction of fear- potentiated startle: blockade by infusion of an NMDA antagonist into the amygdala. *J Neurosci* 12: 854–863.
- Falkenstein E., Tillmann H.C., Christ M., Feuring M. and Wehling M. (2000) Multiple actions of steroid hormones--a focus on rapid, nongenomic effects. *Pharmacol Rev.* 52: 513-556.
- Fatemi S.H., Halt A.R., Realmuto G., Earle J., Kist D.A., Thuras P. and Merz A. (2002) Purkinje cell size is reduced in cerebellum of patients with autism. *Cell Mol Neurobio.* 22: 171-175.

- Fatemi S.H., Folsom T.D., Rooney R.J. and Thuras P.D. (2013) mRNA and protein expression for novel GABA<sub>A</sub> receptors  $\theta$  and  $\rho 2$  are altered in schizophrenia and mood disorders; relevance to FMRP-mGluR5 signaling pathway. *Transl Psychiatry*. 3: e271.
- Ferguson J.N., Aldag J.M., Insel T.R. and Young L.J. (2001) Oxytocin in the medial amygdala is essential for social recognition in the mouse. *J. Neurosci*. 21: 8278-8285.
- Fester L., Prange-Kiel J., Jarry H. and Rune G.M. (2011) Estrogen synthesis in the hippocampus. *Cell Tissue Res*. 345: 285-294.
- Fester L. and Rune G.M. (2014) Sexual neurosteroids and synaptic plasticity in the hippocampus *Brain Res*. S0006-8993: 01435-0138.
- Fink G. and Sumner B.E. (1996) Oestrogen and mental state. *Nature*. 383: 306.
- Finkelstein J.W., Susman E.J., Chinchilli V.M., Kunselman S.J., D'Arcangelo M.R., Schwab J., Demers L.M., Liben L.S., Lookingbill G. and Kulin H.E. (1997) Estrogen or testosterone increases self-reported aggressive behaviors in hypogonadal adolescents. *J Clin Endocrinol Metab*. 82: 2433-2438.
- Fiocchetti M., Ascenzi P. and Marino M. (2012) Neuroprotective effects of 17 $\beta$ -estradiol rely on estrogen receptor membrane initiated signals. *Front Physiol*. 3: 73
- Floyer-Lea A., Wylezinska M., Kincses T. and Matthews P.M. (2006) Rapid modulation of GABA concentration in human sensorimotor cortex during motor learning. *J. Neurophysiol*. 95: 1639-1644.
- Foy M.R., Baudry M., Akopian G.K. and Thompson R.F. (2010) Regulation of hippocampal synaptic plasticity by estrogen and progesterone. *Vitam Horm*. 82: 219-39.
- Foy M.R., Baudry M., Brinton, R.D., and Thompson R.F. (2008) Estrogen and Hippocampal Plasticity in Rodent Models. *J Alzheimers Dis*. 15: 589-603.
- Franklin, K.B.J. and Paxinos, G. (2008) *The mouse brain in stereotaxic coordinates 3rd Edition*. Elsevier Ltd, Amsterdam.
- Gafford G.M., Parsons R.G. and Helmstetter F.J. (2005) Effects of post-training hippocampal injections of midazolam on fear conditioning. *Learn Mem*. 12: 573-578.

- Gao N., Nester R.A. and Sarkar M.A. (2004) 4-Hydroxy estradiol but not 2-hydroxy estradiol induces expression of hypoxia-inducible factor 1alpha and vascular endothelial growth factor A through phosphatidylinositol 3-kinase/Akt/FRAP pathway in OVCAR-3 and A2780-CP70 human ovarian carcinoma cells. *Toxicol Appl Pharmacol.* 196: 124-135.
- Gasnier B. (2004) The SLC32 transporter, a key protein for the synaptic release of inhibitory amino acids. *Pflugers Arch.* 447: 756-759.
- Geddes J., Huws R. and Pratt P. (1991) . Olfactory acuity in the positive and negative syndromes of schizorenia. *Biol. Psychiatry.* 29: 774 – 778.
- Geisler J.G., Zawalich W., Zawalich K., Lakey J.R., Stukenbrok H., Milici A.J. and Soeller W.C. (2002) Estrogen can prevent or reverse obesity and diabetes in mice expressing human islet amyloid polypeptide. *Diabetes.* 51: 2158-2169.
- Genazzani A.R., Spinetti A., Gallo R. and Bernardi F. (1999) Menopause and the central nervous system: intervention options. *Maturitas.* 31: 103-110.
- Gentet L.J. (2012) Functional diversity of supragranular GABAergic neurons in the barrel cortex. *Front Neural Circuits.* 6: 52.
- Gibaldi M. (2000) Are phytoestrogens a "natural alternative" to estrogen replacement therapy? *West J Med.* 173: 273.
- Gillies G.E., McArthur S. (2010) Estrogen actions in the brain and the basis for differential action in men and women: a case for sex-specific medicines. *Pharmacol Rev.* 62: 155-98.
- Glick I.D. and Stewart D. (1980) A new drug treatment for premenstrual exacerbation of schizophrenia. *Compr Psychiatry.* 21: 281-287.
- Goddard A.W., Mason G.F., Almai A., Rothman D.L., Behar K.L., Petroff O.A. et al. (2001). Reductions in occipital cortex GABA levels in panic disorder detected with 1 h-magnetic resonance spectroscopy. *Arch Gen Psychiatry.* 58: 556–561.
- Goddard A.W., Mason G.F., Appel M., Rothman D.L., Gueorguieva R., Behar K.L. et al. (2004) Impaired GABA neuronal response to acute benzodiazepine administration in panic disorder. *Am J Psychiatry* 161: 2186–2193.

- Golden S.A., Covington H.E. 3rd., Bertin O., Russo S.J. (2011) A standardized protocol for repeated social defeat stress in mice. *Nat. Protoc.* 6, 1183.
- Gonzalez-Burgos G., Fish K.N. and Lewis D.A. (2011) GABA neuron alterations, cortical circuit dysfunction and cognitive deficits in schizophrenia. *Neural Plast.*:723184.
- Goodson J.L. and Bas A.H. (2001) Social behavior functions and related anatomical characteristics of vasotocin/vasopressin systems in vertebrates, *Brain Research* 35: 245–265.
- Goulding E.H., Schenk A.K., Juneja P., MacKay A.W., Wade J.M., Tecott L.H. (2008) A robust automated system elucidates mouse home cage behavioral structure. *Proc Natl Acad Sci USA.* 105: 20575-20582.
- Green S. and Vale A.L. (1992) Role of amygdaloid nuclei in the anxiolytic effects of benzodiazepines in rats. *Behav Pharmacol* 3: 261–264
- Green P.S., Perez E.J., Calloway T. and Simpkins J.W. (2000) Estradiol attenuation of beta-amyloid-induced toxicity: a comparison. *J Neurocytol.* 29: 419-423.
- Greif K.F., Erlander M.G., Tillakaratne N.J.K. and Tobin A.J. (1991) Postnatal expression of glutamate decarboxylases in developing rat cerebellum. *Neurochem . Res.* 16: 235-242.
- Gribkoff V.K., Pieschl R.L., Wisialowski T.A., Park W.K., Strecker G.J., DeJeu M.T.G., Pennartz C.M.A. and Dudek F.E. (1999) A re-examination of the role of GABA in the mammalian suprachiasmatic nucleus. *J Biol Rhythms* 14: 126–130.
- Grigoriadis S. and Kennedy S.H. (2002) Role of estrogen in the treatment of depression. *Am J Ther.* 9: 503-509.
- Gross C., Santarelli L., Brunner D., Zhuang X., Hen R., Edwards, H. E. and Burnham, W. (2000) Altered fear circuits in 5-HT(1A) receptor KO mice. *Biol Psychiatry* 48: 1157-63.
- Gudiño-Cabrera G. and Nieto-Sampedro M. (1999) Estrogen receptor immunoreactivity in Schwann-like brain macroglia. *J Neurobiol.* 40: 458-470.

- Guidotti A., Auta J., Davis J.M., Di-Giorgi-Gerevini V., Dwivedi Y., Grayson D.R., Impagnatiello F., Pandey G., Pesold C., Sharma R., Uzunov D. and Costa E. (2000) Decrease in reelin and glutamic acid decarboxylase67 (GAD67) expression in schizophrenia and bipolar disorder: a postmortem brain study. *Arch Gen Psychiatry*. 57: 1061-1069.
- Guidotti A., Auta J., Davis J.M., Dong E., Grayson D.R., Veldic M., Zhang X. and Costa E. (2005) GABAergic dysfunction in schizophrenia: new treatment strategies on the horizon. *Psychopharmacology (Berl)*. 180: 191-205.
- Gupta R., Assalman I. and Bottlender R. (2012) Menopause and schizophrenia. *Menopause Int*. 18: 10-14.
- Hackmann A. and Holmes E.A. (2004) Reflecting an imagery: A clinical perspective and overview of the special issue of memory on mental imagery and memory in psychopathology. *Memory*. 12: 389-402.
- Hagihara K.M. and Ohki K. (2013) Long-term down-regulation of GABA decreases orientation selectivity without affecting direction selectivity in mouse primary visual cortex. *Front Neural Circuits*. 10: 3389.
- Han S., Tai C., Westenbroek R.E., Yu F.H., Cheah C.S., Potter G.B., Rubenstein J.L., Scheuer T., de la Iglesia H.O. and Catterall W.A. (2012) Autistic-like behaviour in *Scn1a*<sup>+/-</sup> mice and rescue by enhanced GABA-mediated neurotransmission. *Nature*. 489: 385-390.
- Hardy S.L., Anderson G.M., Valent M., Connors J.M. and Goodman R.L. (2003) Evidence that estrogen receptor alpha, but not beta, mediates seasonal changes in the response of the ovine retrochiasmatic area to estradiol. *Biol Reprod*. 68: 846-852.
- Hartman A.L. , Gasior M., Vining E.P. and Rogawski M.A. (2007) The neuropharmacology of the ketogenic diet. *Pediatr Neurol*. 36: 281-92.
- Hashimoto T., Volk D.W., Eggan S.M., Mirnics K., Pierri J.N., Sun Z., Sampson A.R., Lewis D.A. (2003) Gene expression deficits in a subclass of GABA neurons in the prefrontal cortex of subjects with schizophrenia. *J. Neurosci*. 23: 6315-6326.



Hatfield T., Spanis C. and McGaugh J.L. (1999) Response of amygdalar norepinephrine to footshock and GABAergic drugs using in vivo microdialysis and HPLC. *Brain Res.* 835: 340-345.

Heckers S., Stome D., Walsh J., Shick J., Koul P., Benes F.M., (2002) Differential hippocampal expression of glutamic acid decarboxylase 65 and 67 messenger RNA in bipolar disorder and schizophrenia. *Arch. Gen. Psychiat.* 59: 521-529.

Heilig M., McLeod S., Brot M., Heinrichs S.C., Menzaghi F., Koob G.F. and Britton K.T. (1993) Anxiolytic-like action of neuropeptide Y: mediation by Y1 receptors in amygdala, and dissociation from food intake effects. *Neuropsychopharmacology.* 8: 357-363.

Heldt S.A., Green A. and Ressler K.J. (2004) Prepulse inhibition deficits in GAD65 knockout mice and the effect of antipsychotic treatment. *Neuropsychopharmacology* 29: 1610–1619.

Heldt S.A., Mou L. and Ressler K.J. (2012). In vivo knockdown of GAD67 in the amygdala disrupts fear extinction and the anxiolytic –like effect of diazepam in mice. *Transl Psychiatry.* 2: e181.

Heldt S.A. and Ressler K.J. (2007). Training-induced changes in the expression of GABAA-associated genes in the amygdala after the acquisition and extinction of Pavlovian fear. *Eur J Neurosci.* 26: 3631-3644.

Hemat R.A.S. (2004). *Principles Of Orthomolecularism.* Urotext. p. 426. ISBN 1-903737-05-2.

Herbison A.E. and Fénelon V.S. (1995) Estrogen regulation of GABAA receptor subunit mRNA expression in preoptic area and bed nucleus of the stria terminalis of female rat brain. *J Neurosci.* 15: 2328-2337.

Herbison A.E. (1997) Estrogen regulation of GABA transmission in rat preoptic area. *Brain Res Bull.* 44: 321-326.

Herd M.B., Belelli D. and Lambert J.J. (2007) Neurosteroid modulation of synaptic and extrasynaptic GABA(A) receptors. *Pharmacol Ther.* 116: 20-34.

Heredia L., Torrente M., Colomina M.T. and Domingo J.L (2014) Assessing anxiety in C57BL/6J mice: A pharmacological characterization of the open-field and light/dark tests. *J Pharmacol Toxicol Methods*. 69: 108-14.

Herzog C.D., Stackman R.W. and Walsh T.J. (1996) Intraseptal flumazenil enhances, while diazepam binding inhibitor impairs, performance in a working memory task. *Neurobiol Learn Mem*. 66: 341-352.

Hettema J.M., An S.S., Neale M.C., Bukszar J., van den Oord E.J., Kendler K.S. and Chen X. (2006) Association between glutamic acid decarboxylase genes and anxiety disorders, major depression, and neuroticism. *Mol Psychiatry*. 11: 752-762.

Hirano Y., Oguni H., Shiota M., Nishikawa A. and Osawa M. (2014) Ketogenic diet therapy can improve ACTH-resistant West syndrome in Japan. *Brain Dev*. S0387: 37-40.

Hirose K. and Chan P.H. (1993) Blockade of glutamate excitotoxicity and its clinical applications. *Neurochem Res*. 18: 479-483.

Hobin J.A, Goosens K.A. and Maren S. (2003) Context-dependent neuronal activity in the lateral amygdala represents fear memories after extinction. *J Neurosci*. 23: 8410-8416.

Honig A., Landgraf R., Ledderhos C. and Quies W. (1987) Plasma vasopressin levels in healthy young men in response to stimulation of the peripheral arterial chemoreceptors by almitrine bismesylate. *Biomed Biochim Acta*. 46: 1043-1049.

Homanics G.E., DeLorey T.M., Firestone L.L., Quinlan J.J., Handforth A., Harrison N.L., Krasowski M.D., Rick C.E., Korpi E.R., Mäkelä R., Brilliant M.H., Hagiwara N., Ferguson C., Snyder K. and Olsen R.W. (1997) Mice devoid of gamma-aminobutyrate type A receptor beta3 subunit have epilepsy, cleft palate, and hypersensitive behavior, *Proc Natl Acad Sci USA* 94: 4143–4148.

Houser C.R. and Esclapez M. (2003) Downregulation of the alpha5 subunit of the GABA(A) receptor in the pilocarpine model of temporal lobe epilepsy. *Hippocampus*. 13: 633-645.

Huang H.S. and Akbarian S. (2007) GAD1 mRNA expression and DNA methylation in prefrontal cortex of subjects with schizophrenia. *PloS One*. 2, e809.

Hudgens E.D., Ji L., Carpenter C.D. and Petersen S.L. (2009) The gad2 promoter is a

transcriptional target of estrogen receptor (ER) alpha and ER beta: a unifying hypothesis to explain diverse effects to estradiol. *J Neurosci.* 29: 8790-8797.

Hu G.X., Zhao B.H., Chu Y.H., Zhou H.Y., Akingbemi B.T., Zheng Z.Q. and Ge R.S. (2010) Effects of genistein and equol on human and rat testicular 3beta-hydroxysteroid dehydrogenase and 17beta-hydroxysteroid dehydrogenase 3 activities. *Asian J Androl.* 12: 519-526.

Impagnatiello F., Guidotti A.R., Pesold C., Dwivedi Y., Caruncho H., Pisu M.G., Uzunov D.P., Smalheiser N.R., Davis J.M., Pandey G.N., Pappas G.D., Tueting P., Sharma R.P., Costa E. (1998) A decrease of reelin expression as a putative vulnerability factor in schizophrenia. *Proc Natl Acad Sci U S A.* 95: 15718-15723.

Imwalle D.B., Scordalakes E.M. and Rissman E.F. (2002) Estrogen receptor alpha influences socially motivated behaviors. *Horm Behav.* 42: 484-491

Jacob T.C., Moss S.J. and Jurd R. (2008) GABA(A) receptor trafficking and its role in the dynamic modulation of neuronal inhibition. *Nat Rev Neurosci* 9: 331-343.

Jacobsen K.R., Kalliokoski O., Teilmann A.C., Hau J. and Abelson K.S. (2012) The effect of isoflurane anaesthesia and vasectomy on circulating corticosterone and ACTH in BALB/c mice. *Gen Comp Endocrinol.* 179: 406-13.

Jasnow A.M and Huhman K.L. (2001) Activation of GABA(A) receptors in the amygdala blocks the acquisition and expression of conditioned defeat in Syrian hamsters. *Brain Res.* 920: 142-150.

Jasnow A.M., Schulkin J. and Pfaff D.W. (2006) Estrogen facilitates fear conditioning and increases corticotropin-releasing hormone mRNA expression in the central amygdala in female mice. *Horm Behav.* 49:197-205.

Javitt D.C. (2004) Glutamate as a therapeutic target in psychiatric disorders. *Mol Psychiatry.* 9: 984-997.

Ji F. and Obata K. (1999) Development of the GABA system in organotypic culture of hippocampal and cerebellar slices from a 67-kDa isoform of glutamic acid decarboxylase (GAD67)-deficient mice. *Neurosci Res.* 33: 233-237.

Joh H.D., Searles R.V., Selmanoff M., Alkayed N.J., Koehler R.C., Hurn P.D. and Murphy S.J. (2006) Estradiol alters only GAD67 mRNA levels in ischemic rat brain with no consequent effects on GABA. *J Cereb Blood Flow Metab.* 26: 518-526.

Jussofie A., Korner I., Schell C. and Hienke C. (1995) Time course of the effects of steroid hormone deprivation elicited by ovariectomy or ovariectomy plus adrenalectomy on the affinity and density of GABA binding sites in distinct rat brain areas. *Exp Clin Endocrinol Diabetes* 103: 196–204.

Jüptner M., Jussofie A. and Hiemke C. (1991) Effects of ovariectomy and steroid replacement on GABAA receptor binding in female rat brain. *J Steroid Biochem Mol Biol.* 38: 141-147.

Kaidanovich-Beilin O., Lipina T., Vukobradovic I., Roder J. and Woodgett J.R. (2011) Assessment of social interaction behaviors. *J Vis Exp.* 48: 2473.

Kaila K. (1994) Ionic basis of GABA<sub>A</sub> receptor channel function in the nervous system. *Prog Neurobiol* 42: 489–537

Krnjevic K. (1976) GABA in Nervous System Function. (Raven, New York)

Kalueff A.V. and Nutt D.J. (2007) Role of GABA in anxiety and depression. *Depress Anxiety.* 24: 495-517.

Kanaani J., Kolibachuk J., Martinez H. and Baekkeskov S. (2010). Two distinct mechanisms target GAD67 to vesicular pathways and presynaptic clusters. *J.Cell Biol.* 190: 911-925.

Kane M.J., Angoa-Peréz M., Briggs D.I., Sykes C.E., Francescutti D.M., Rosenberg D.R. and Kuhn D.M. (2012) Mice genetically depleted of brain serotonin display social impairments, communication deficits and repetitive behaviors: possible relevance to autism. *PLoS One.* 7: e48975.

Karlsen A.E., Hagopian W.A., Grubin C.E., Dube S., Disteché C.M., Adler D.A., Bärmeier H., Mathewes S., Grant F.J., Foster D., et al. (1991) Cloning and primary structure of a human islet isoform of glutamic acid decarboxylase from chromosome 10. *Proc Natl Acad Sci U S A.* 88: 8337-8341.

Kash S.F., Johnson R.S., Tecott L.H., Noebels J.L., Mayfield R.D., Hanahan D. and Baekkeskov S. (1997) Epilepsy in mice deficient in the 65-kDa isoform of glutamic acid decarboxylase. *Proc Natl Acad Sci U S A.* 94: 14060-14065.

Kash S.F., Tecott L.H., Hodges C. and Beekkeskov (1999) Increased anxiety and altered responses to anxiolytics in mice deficient in the 65-kDa isoform of glutamic acid decarboxylase. *Proc. Natl. Acad. Sci. USA* 96: 1698–1703.

- Kaufman D.L., Houser C.R. and Tobin A.J. (1991) Two forms of the gamma-aminobutyric acid synthetic enzyme glutamate decarboxylase have distinct intraneuronal distributions and cofactor interactions. *J Neurochem.* 56: 720-723.
- Kavaliers M., Agmo A., Choleris E., Gustafsson J.A., Korach K.S., Muglia L.J., Pfaff D.W. and Ogawa S. (2004) Oxytocin and estrogen receptor alpha and beta knockout mice provide discriminably different odor cues in behavioral assays. *Genes Brain Behav.* 3: 189-195.
- Keverne E.B. (2004) Importance of olfactory and vomeronasal systems for male sexual function. *Physiol Behav.* 83:177-187.
- Kitaoka M., Kadokawa H., Sugano M., Ichikawa K., Taki M., Takaishi S., Iijima Y., Tsutsumi S., Boriboon M. and Akiyama T. Prenylflavonoids: a new class of non-steroidal phytoestrogen (Part 1). Isolation of 8-isopentenylnaringenin and an initial study on its structure-activity relationship. *Planta Med.* 64: 511-515.
- Klinge C.M. (2001) Estrogen receptor interaction with estrogen response elements. *Nucleic Acids Res.* 29: 2905-2919.
- Kobori N. and Dash P.K. (2006) Reversal of brain injury-induced prefrontal glutamic acid decarboxylase expression and working memory deficits by D1 receptor antagonism. *J Neurosci.* 26: 4236-4246.
- Kohwi M., Petryniak M.A., Long J.E., Ekker M., Obata K., Yanagawa Y., Rubenstein J.L. and Alvarez-Buylla A. (2007) A subpopulation of olfactory bulb GABAergic interneurons is derived from Emx1- and Dlx5/6-expressing progenitors. *J Neurosci.* 27: 6878-6891.
- Koolhaas J.M., Coppens C.M., de Boer S.F., Buwalda B., Meerlo P. and Timmermans P.J. *J Vis Exp.* 77: e4367.
- Korpi E.R. and Sinkkonen S.T. (2006) GABA(A) receptor subtypes as targets for neuropsychiatric drug development. *Pharmacol Ther.* 109:12-32.
- Kostelac D., Rechkemmer G. and Briviba K. (2003) Phytoestrogens modulate binding response of estrogen receptors alpha and beta to the estrogen response element. *J Agri Food Chem.* 51: 7632-7635.

- Kralic J.E., Korpi E.R., O'Buckley T.K., Homanics G.E. and Morrow A.L. (2002) Molecular and pharmacological characterization of GABA(A) receptor alpha1 subunit knockout mice. *J Pharmacol Exp Ther.* 302: 1037-45.
- Krezel W., Dupont S., Krust A., Chambon P. and Chapman P.F. (2001) Increased anxiety and synaptic plasticity in estrogen receptor beta -deficient mice. *Proc Natl Acad Sci U S A.* 98: 12278-12282.
- Kronenberg F. and Fugh-Berman A. (2002) Complementary and alternative medicine for menopausal symptoms: a review of randomized, controlled trials. *Ann Intern Med* 137: 805– 813.
- Kruijver FP and Swaab DF. (2002) Sex hormone receptors are present in the human suprachiasmatic nucleus. *Neuroendocrinology.* 75: 296-305.
- Kruijver F.P., Balesar R., Espila A.M., Unmehopa U.A. and Swaab D.F. (2002) Estrogen receptor-alpha distribution in the human hypothalamus in relation to sex and endocrine status. *J Comp Neurol.* 454: 115-139.
- Kudwa A.E., Bodo C., Gustafsson J.A. and Rissman E.F. (2005) A previously uncharacterized role for estrogen receptor beta: defeminization of male brain and behavior. *Proc Natl Acad Sci U S A* 102: 4608 – 4612.
- Kulkarni J., Riedel A., de Castella A.R., Fitzgerald P.B., Rolfe T.J., Taffe J. and Burger H. (2001) Estrogen - a potential treatment for schizophrenia *Schizophr Res.* 48: 137-44.
- Kushner P.J., Agard D.A., Greene G.L., Scanlan T.S., Shiau A.K., Uht R.M. and Webb P. (2000) Estrogen receptor pathways to AP-1. *J Steroid Biochem Mol Biol.* 74: 311-317.
- Kutiyanawalla A., Promsote W., Terry A. and Pillai A. (2012) Cysteamine treatment ameliorates alterations in GAD67 expression and spatial memory in heterozygous reeler mice. *Int J Neuropsychopharmacol.* 15: 1073-1086.
- Lane S.D. and Gowin J.L. (2009) GABAergic modulation of human social interaction in a prisoner's dilemma model by acute administration of alprazolam. *Behav. Pharmacol.* 20: 657-661.
- Laxmi T.R., Stork O. and Pape H.C. (2003). Generalization of conditioned fear and its behavioral expression in mice. *Beh. Brain Res.* 145: 89-98.

- Le Bail J.C., Champavier Y., Chulia A.J. and Habrioux G. (2000) Effects of phytoestrogens on aromatase, 3beta and 17beta-hydroxysteroid dehydrogenase activities and human breast cancer cells. *Life Sci.* 66: 1281-1291.
- LeDoux J.E. (2000) Emotion circuits in the brain. *Annu Rev Neurosci.* 23: 155-184.
- Lehman M.N. and Winans S.S. (1982) Vomeronasal and olfactory pathways to the amygdala controlling male hamster sexual behavior: autoradiographic and behavioral analyses. *Brain Res.* 240: 27-41.
- Lephart E.D. (2001) Visual spatial memory is enhanced in female rats (but inhibited in males) by dietary soy phytoestrogens. *BMC Neurosci.* 2: 20
- Lephart E.D., Adlercreutz H. and Lund T.D. (2001) Dietary soy phytoestrogen effects on brain structure and aromatase in Long-Evans rats. *Neuroreport.* 12: 3451-3455.
- Lephart E.D., Setchell K.D. and Lund T.D. (2005). Phyestrogens: hormonal action and brain plasticity. *Brain Res Bull.* 65: 193-198
- Lepart E.D., West T.W., Weber K.S., Rhees R.W., Setchell K.D., Adlercreutz H. and Lund T.D. (2002). Neurobehavioral effects of dietary soy phytoestrogens. *Neurotoxicol Teratol.* 24: 5-16.
- Levin E.R. (2009) Plasma membrane estrogen receptors. *Trends Endocrinol Metab.* 20: 477-482.
- Levitt P. (2005) Disruption of interneuron development. *Epilepsia.* 46: 22-28.
- Li D., Collier D.A. and He L. (2006) Meta-analysis shows strong positive association of the neuregulin 1 (NRG1) gene with schizophrenia. *Hum Mol Genet.* 15: 1995-2002.
- Lieb K., Reisert I. and Pilgrim C. (1994) Differentiation of hypothalamic GABAergic neurons in vitro: absence of effects of sex and gonadal steroids. *Exp Brain Res.* 99: 435-440.
- Liedtke W.B. and Heller S. (2007) TRP Ion Channel Function in Sensory Transduction and Cellular Signaling Cascades. *Front Neurosci.* 102: 915-20.
- Lieving L.M., Cherek D.R., Lane S.D., Tcheremissine O.V. and Nouvion S.O. (2008) Effects of acute tiagabine administration on aggressive responses of adult male parolees. *J Psychopharmacol.* 22: 144-152.

Lin C.Y., Tsai C.Y. and Lin S.H. (2005) Effects of soy components on blood and liver lipids in rats fed high-cholesterol diets. *World J Gastroenterol.* 11: 5549-5552.

Lindamer L.A., Lohr J.B., Harris M.J. and Jeste D.V. (1997) Gender, estrogen, and schizophrenia. *Psychopharmacol Bull.* 33: 221-228.

Liou S.Y. and Albers H.E. (1990) Single unit response of neurons within the hamster suprachiasmatic nucleus to GABA and low chloride perfusate during day and night. *Brain Res Bull* 25: 93–98.

Liou S.Y., Shibata S., Albers H.E. and Ueki S. (1990) Effects of GABA and anxiolytics on the single unit discharge of suprachiasmatic neurons in rat hypothalamic slices. *Brain Res Bull* 25: 103–104.

Litwack G. (2010) Pheromones. Preface. *Vitam Horm.* 83:21-22

Liu D., Zhang Z. and Teng C.T. (2005) Estrogen-related receptor-gamma and peroxisome proliferator-activated receptor-gamma coactivator-1alpha regulate estrogen-related receptor-alpha gene expression via a conserved multi-hormone response element. *J Mol Endocrinol.* 34: 473-487.

Liu C. and Reppert S.M. (2000) GABA synchronizes clock cells within the suprachiasmatic circadian clock. *Neuron* 25: 123–128

Livak K.J. and Schmittgen T.D. (2001) Analysis of relative gene expression data using real-time quantitative PCR and the 2(-Delta Delta C(T)) Method. *Methods.* 25: 402-408

Luft T., Pereira G.S., Cammarota M. and Izquierdo I. (2004) Different time course for the memory facilitating effect of bicuculline in hippocampus, entorhinal cortex, and posterior parietal cortex of rats. *Neurobiol Learn Mem.* 82: 52-56.

Lumley L.A., Sipos M.L., Charles R.C., Charles R.F., Meyerhoff J.L. (1999) Social stress effects on territorial marking and ultrasonic vocalizations in mice. *Physiol Behav.* 67: 769-775.

Lund T.D., Munson D.J., Haldy M.E., Setchell K.D., Lepart E.D. and Handa R.J. (2004). Equol is a novel anti-androgen that inhibits prostate growth and hormone feedback. *Biol Reprod.* 70: 1188-1195.

Lund T.D., Rovis T., Chung W.C. and Handa R.J. (2005) Novel actions of estrogen receptor-beta on anxiety-related behaviors. *Endocrinology* 146: 797– 807.



- Luscher B., Shen Q. and Sahir N. (2011) The GABAergic deficit hypothesis of major depressive disorder. *Mol Psychiatry*. 16: 383-406.
- Lund T.D., West T.W., Tian L.Y., Bu L.H., Simmons D.L., Setchell K.D.R., Adelercreutz H. and Lepart E.D. (2001) Visual spatial memory is enhanced in female rats (but inhibited in males) by dietary soy phytoestrogens. *BMC Neurosci* 2: 20.
- Lydiard R.B. (2003) The role of GABA in anxiety disorders. *J Clin Psychiatry*. 64: 21-27.
- Madsen K.K., Clausen R.P., Larsson O.M., Krogsgaard-Larsen P., Schousboe A. and White H.S. (2009) Synaptic and extrasynaptic GABA transporters as targets for anti-epileptic drugs. *J Neurochem*. 109: 139-44.
- Maggi A., Perez J. (1986) Estrogen-induced up-regulation of  $\gamma$ -aminobutyric acid receptors in the CNS of rodents. *J Neurochem*. 47: 1793-1797.
- Majewska M.D. (1992) Neurosteroids: endogenous bimodal modulators of the GABA(A) receptor. Mechanism of action and physiological significance. *Prog Neurobiol* 38: 379-395.
- Makkar S.R., Zhang S.Q. and Cranney J. (2010) Behavioral and neural analysis of GABA in the acquisition, consolidation, reconsolidation, and extinction of fear memory. *Neuropsychopharm*. 35: 1625-1652.
- Makkar S.R., Zhang S.Q. and Cranney J. (2012) Behavioral and Neural Analysis of GABA in the Acquisition, Consolidation, Reconsolidation, and Extinction of Fear Memory. *Neuropsychopharmacology*. 35: 1625-1652.
- Maldonado N.M., Espejo P.J., Martijena I.D. and Molina V.A. (2014) Activation of ERK2 in basolateral amygdala underlies the promoting influence of stress on fear memory and anxiety: influence of midazolam pretreatment. *Eur Neuropsychopharmacol*. 24: 262-270.
- Malaspina D. and Coleman E. (2003) Olfaction and social drive in schizophrenia. *Arch. Gen. Psychiat*. 60: 578-584.
- Malaspina D., Goetz R., Keller A., Messinger J.W., Bruder G., Goetz D., Opler M, Harlap S., Harkavy-Friedman J. and Antonius D. (2012) Olfactory processing, sex effects and heterogeneity in schizophrenia. *Schizophr. Res*. 135: 144.

- Manor D., Rothman D.L., Mason G.F., Hyder F., Petroff O.A., Behar K.L. (1996) The rate of turnover of cortical GABA from [1-<sup>13</sup>C]glucose is reduced in rats treated with the GABA-transaminase inhibitor vigabatrin (gamma-vinyl GABA). *Neurochem Res.* 21: 1031-41.
- Marino M., Galluzzo P. and Ascenzi P. (2006) Estrogen signalling multiple pathways to impact gene transcription *Curr Genomics.* 7: 497-508.
- Maren S. (2001) Neurobiology of Pavlovian fear conditioning. *Annu Rev Neurosci.* 24: 897-931.
- Maren S.(2008) Pavlovian fear conditioning as a behavioral assay for hippocampus and amygdala function: cautions and caveats. *Eur J Neurosci.* 28:1661-1666.
- Maren S. and Holt W. (2000) The hippocampus and contextual memory retrieval in Pavlovian conditioning. *Behav Brain Res.* 110: 97-108.
- Maren S. and Quirk G.J. (2004) Neuronal signalling of fear memory. *Nat Rev Neurosci.* 5: 844-852.
- Markham J.A. and Koenig J.I. (2011) Prenatal stress: role in psychotic and depressive diseases. *Psychopharmacology (Berl)* 214: 89-106.
- Mark L.P., Prost R.W., Ulmer J.L., Smith M.M., Daniels D.L., Strottmann J.M., Brown W.D. and Hance-Bey L. (2001) Pictorial review of glutamate excitotoxicity: fundamental concepts for neuroimaging. *AJNR Am J Neuroradiol.* 22: 1813-1824.
- Martin D.L., Martin S.B., Wu S.J. and Espina N. (1991) Regulatory properties of brain glutamate decarboxylase (GAD): the apoenzyme of GAD is present principally as the smaller of two molecular forms of GAD in brain. *J Neurosci.* 11: 2725-2731.
- Martin D.L. and Rimvall K. (1993). Regulation of gamma-aminobutyric acid synthesis in the brain. *J Neurochem.* 60: 395-407.
- Matthies A, Loh G, Blaut M, Braune A. (2012) Daidzein and genistein are converted to equol and 5-hydroxy-equol by human intestinal *Slackia isoflavoniconvertens* in gnotobiotic rats. *J Nutr.* 142: 40-46.
- Maruniak J.A., Wysocki C.J., Taylor J.A. (1986) Mediation of male mouse urine marking and aggression by the vomeronasal organ. *Physiol Behav.* 37: 655-657.

- Matsuda H., Shimoda H., Morikawa T. and Yoshikawa M. (2001) Phytoestrogens from the roots of *Polygonum cuspidatum* (Polygonaceae): structure-requirement of hydroxyanthraquinones for estrogenic activity. *Bioorg Med Chem Lett.* 11: 1839-1842.
- Matsuda J., Vanier M.T., Saito Y., Suzuki K. and Suzuki K. (2001) Dramatic phenotypic improvement during pregnancy in a genetic leukodystrophy: estrogen appears to be a critical factor. *Hum Mol Genet.* 10: 2709-2715.
- Matthies A., Loh G., Blaut M. and Braune A. (2012) Daidzein and genistein are converted to equol and 5-hydroxy-equol by human intestinal *Slackia isoflavoniconvertens* in gnotobiotic rats. *J Nutr.* 142: 40-46.
- McCarthy M.M., Kaufman L.C., Brooks P.J., Pfaff D.W. and Schwartz-Giblin S. (1995). Estrogen modulation of mRNA levels for the two forms of glutamic acid decarboxylase (GAD) in female rat brain. *J Comp Neurol.* 360: 685-697.
- McCullough L.D., Alkayed N.J., Traystman R.J., Williams M.J. and Hurn P.D. (2001) Postischemic estrogen reduces hypoperfusion and secondary ischemia after experimental stroke. *Stroke.* 32: 796-802.
- McDonald A.J. and Pearson J.C. (1989) Coexistence of GABA and peptide immunoreactivity in non-pyramidal neurons of the basolateral amygdala. *Neurosci Lett.* 100: 53-58.
- McDonald A.J., Mascagni F. and Muller J.F. (2004) Immunocytochemical localization of GABABR1 receptor subunits in the basolateral amygdala. *Brain Res.* 1018:147-58.
- McDonald A.J. and Mascagni F. (2004) Parvalbumin-containing interneurons in the basolateral amygdala express high levels of the alpha1 subunit of the GABAA receptor. *J Comp Neurol* 473: 137–146
- McKernan R.M., Rosahl T.W., Reynolds D.S., Sur .C, Wafford K.A., Atack J.R., Farrar S., Myers J., Cook G., Ferris P., Garrett L., Bristow L., Marshall G., Macaulay A., Brown N., Howell O., Moore K.W., Carling R.W., Street L.J., Castro J.L., Ragan C.I., Dawson G.R. and Whiting P.J. (2000). Sedative but not anxiolytic properties of benzodiazepines are mediated by the GABA(A) receptor alpha1 subtype. *Nat Neurosci.* 3: 587-592.

Mendrek A. and Stip E. (2011) Sexual dimorphism in schizophrenia: is there a need for gender-based protocols? *Expert Rev Neurother.* 11: 951-959.

Meerlo P., Van-den Hoofdakker R.H., Koolhass J.M., Daan S., 1997. Stress-induced changes in circadian rhythms of body temperature and activity in rats are not caused by pacemaker changes. *J. Biol. Rhyth.* 12: 80-92.

Meinhard N., Kessing L.V. and Vinberg M. (2014) The role of estrogen in bipolar disorder, a review. *Nord J Psychiatry.* 68: 81-7.

Menold M.M., Shao Y., Wolpert C.M., Donnelly S.L., Raiford K.L., Martin E.R., Ravan S.A., Abramson R.K., Wright H.H., Delong G.R., Cuccaro M.L., Pericak-Vance M.A. and Gilbert J.R. (2001) Association analysis of chromosome 15 gabaa receptor subunit genes in autistic disorder. *J Neurogenet.* 15: 245-259

Merchenthaler I., Lane M.V., Numan S., Dellovade T.L. (2004) Distribution of estrogen receptor alpha and beta in the mouse central nervous system: in vivo autoradiographic and immunocytochemical analyses. *J Comp Neurol.* 473:270-91.

Meredith M. (1991) Sensory processing in the main and accessory olfactory systems: comparisons and contrasts. *J Steroid Biochem Mol Biol.* 39: 601-614.

Miczek K.A., Fish E.W. and De-Bold J.F. (2003) Neurosteroids, GABAA receptors, and escalated aggressive behavior. *Horm. Behav.* 44: 242-257.

Mikulecka A., Subrt M., Stuchlik A., and Kubova H. (2014) Consequences of early postnatal benzodiazepines exposure in rats.I. Cognitive-like behavior. *Front. Behav. Neurosci.* 8:101.

Milligan S.R., Kalita J.C., Heyerick A., Rong H., De Cooman L. and De Keukeleire D. (1999) Identification of a potent phytoestrogen in hops (*Humulus lupulus* L.) and beer. *J Clin Endocrinol Metab.* 84: 2249-2252.

Mody I., De Koninck Y., Otis T.S. and Soltesz I. (1994) Bridging the cleft at GABA synapses in the brain. *Trends Neurosci* 17: 517–525.

Montani G., Tonelli S., Sanghez V., Ferrari P.F., Palanza P., Zimmer A. and Tirindelli R. (2013) Aggressive behaviour and physiological responses to pheromones are strongly impaired in mice deficient for the olfactory G-protein  $\gamma$ -subunit, *G $\gamma$ 8*. *J Physiol.*

591: 3949-3962.

Moore T.O., Karom M. and O'Farrell L. (2004) The neurobehavioral effects of phytoestrogens in male Syrian hamsters. *Brain Res.* 1016: 102-110.

Mucignat-Caretta C., Cavaggioni A. and Caretta A. (2004) Male urine chemosignals differentially affects aggressive behavior in male mice. *J. Chem. Ecol.* 30: 777-791.

Muller J.F., Mascagni F. and McDonald A.J. (2007) Postsynaptic targets of somatostatin-containing interneurons in the rat basolateral amygdala. *J Comp Neurol* 500: 513–529.:

Mueller S.O., Simon S., Chae K., Metzler M. and Korach K.S. (2004). Phytoestrogens and their human metabolites show distinct agonistic and antagonistic properties on estrogen receptor alpha (ERalpha) and ERbeta in human cells. *Toxicol Sci.* 80: 14-25.

Mula M. (2011) GABAergic drugs in the treatment of epilepsy: modern or outmoded? *Future Med Chem.* 3:177-182.

Murray B. Herd, Delia Belelli, Jeremy J. Lambert (2007) Neurosteroid modulation of synaptic and extrasynaptic GABA(A) receptors. *Pharmacology and therapeutic.* 116: 20-34.

Murakami G., Hunter R.G., Fontaine C., Ribeiro A. and Pfaff D. (2011) Relationships among estrogen receptor, oxytocin and vasopressin gene expression and social interaction in male mice. *Eur J Neurosci.* 34: 469-477.

Murphy D.D., Cole N.B., Greenberger V. and Segal M. (1998). Estradiol Increases Dendritic Spine Density by Reducing GABA Neurotransmission in Hippocampal Neurons. *J Neurosci.* 18: 2550–2559.

Murphy D.D., Cole N.B. and Segal M. (1998) Brain-derived neurotrophic factor mediates estradiol-induced dendritic spine formation in hippocampal neurons. *Proc Natl Acad Sci U S A.* 95: 11412-11417.

Nader K., Schafe G.E. and Le Doux J.E. (2000) Fear memories require protein synthesis in the amygdala for reconsolidation after retrieval. *Nature.* 406: 722-726.

- Nakamura T.J., Sellix M.T., Menaker M. and Block G.D. (2008). Estrogen directly modulates circadian rhythms of PER2 expression in the uterus. *Am J Physiol Endocrinol Metab.* 295: E1025-E1031.
- Nakamura N.H., Rosell D.R., Akama K.T. and McEwen B.S. (2004) Estrogen and ovariectomy regulate mRNA and protein of glutamic acid decarboxylases and cation-chloride cotransporters in the adult rat hippocampus. *Neuroendocrinology.* 80: 308-23.
- Namchuk M., Lindsay L., Turck C.W., Kanaani J. and Baekkeskov S. (1997) Phosphorylation of serine residues 3, 6, 10, and 13 distinguishes membrane anchored from soluble glutamic acid decarboxylase 65 and is restricted to glutamic acid decarboxylase 65alpha. *J Biol Chem.* 272: 1548-1557.
- Nelson R.J. and Trainor BC. (2007) Neural mechanisms of aggression. *Nat Rev Neurosci.* 8: 536-546.
- Newman S.W. (1999) The medial extended amygdala in male reproductive behavior. A node in the mammalian social behavior network. *Ann N Y Acad Sci.* 877: 242-257.
- Nicolas L.B. and Prinszen E.P. (2006) Social approach-avoidance behavior of a high anxiety strain of rats: effects of benzodiazepine receptors ligands. *Psychopharmacology* 184: 65-74.
- Nicot A., Otto T., Brabet P. and Dicicco-Bloom E.M. (2004). Altered social behavior in pituitary adenylate cyclase-activating polypeptide type I receptor-deficient mice. *J. Neurosci.* 24: 8786-8795.
- Niehoff D.L. and Kuhar M.J. (1983) Benzodiazepine receptors: localization in rat amygdala. *J Neurosci.* 3: 2091-2097.
- Nilsson S., Mäkelä S., Treuter E., Tujague M., Thomsen J., Andersson G., Enmark E., Pettersson K., Warner M. and Gustafsson J.A. (2001) Mechanisms of estrogen action. *Physiol Rev.* 81: 1535-1565.
- Noriega N.C., Eghlidi D.H., Garyfallou V.T., Kohama S.G., Kryer S.G. and Urbanski H. (2010). Influence of 17beta-estradiol and progesterone on GABAergic gene expression in the arcuate nucleus, amygdala and hippocampus of the rhesus macaque. *Brain Res.* 1307: 28-42.

Novotny M., Harvey S., Jemiolo B. and Alberts J. (1985) Synthetic pheromones that promote inter-male aggression in mice. *Proc. Natl. Acad. Sci. USA.* 82: 2059-2061.

Nutt D.J., Besson M., Wilson S.J. Dawson G.R. and Lingford-Hughes R. (2007) Blockade of alcohol's amnestic activity in humans by an  $\alpha_5$  subtype benzodiazepine receptor inverse agonist. *Neuropharmacology* 53: 810–820.

O'Connor L.H., Neck B., McEwen B.S. (1988) Regional specificity of gamma-aminobutyric acid receptor regulation by estradiol. *Neuroendocrinology* 47: 473-481

Ochoa S., Usall J., Cobo J., Labad X. and Kulkarni J. (2012) Gender differences in schizophrenia and first-episode psychosis: a comprehensive literature review. *Schizophr Res Treatment*: 916198.

Okamura H, Béroud A, Julien JF, Geffard M, Kitahama K, Mallet J, Bobillier P (1989). Demonstration of GABAergic cell bodies in the suprachiasmatic nucleus: in situ hybridization of glutamic acid decarboxylase (GAD) mRNA and immunocytochemistry of GAD and GABA. *Neurosci Lett* 102: 131–136.

Oliver B. and Young L.J. (2002) Animal models of aggression. *Neuropsychopharmacology: The Fifth Generation of progress*

Olivera-Lopez J.I., Molina-Hernández M., Tellez-Alcántara N.P. and Jaramillo M.T. (2008) Estradiol and neuropeptide Y (intra-lateral septal) reduce anxiety-like behavior in two animal models of anxiety. *Peptides.* 29: 1396-1403.

Olmos-Serrano J.L., Paluszkiewicz S.M., Martin B.S., Kaufmann W.E., Corbin J.G. and Huntsman M.M. (2010) Defective GABAergic neurotransmission and pharmacological rescue of neuronal hyperexcitability in the amygdala in a mouse model of fragile X syndrome. *J. Neurosci.* 30: 9929–9938.

Olsen R.W. and Sieghart W. (2008) International Union of Pharmacology. LXX. Subtypes of  $\gamma$ -aminobutyric acid<sub>A</sub> receptors: classification on the basis of subunit composition, pharmacology, and function. *Pharmacol Rev* 60: 243–260.

Osako Y., Otsuka T., Taniguchi M., Oka T., Kaba H., 2000. Oxytocin depresses spontaneous gamma-aminobutyric acid-ergic inhibitory postsynaptic currents in cultured mitral cells of the rat olfactory bulb by a presynaptic mechanism. *Neurosci. Lett.* 289: 25-28.

- Ososki A.L. and Kennelly E.J. (2003) Phytoestrogens: a review of the present state of research. *Phytother Res.* 17: 845-869.
- Osterlund M., Kuiper G.G., Gustafsson J.A., Hurd Y.L. (1998) Differential distribution and regulation of estrogen receptor-alpha and -beta mRNA within the female rat brain. *Brain Res Mol Brain Res.* 54:175-80.
- Oukari U.M. and Korpi E.R. (2010) Regulation of GABA<sub>A</sub> Receptor Subunit Expression by Pharmacological Agents. *Pharmacological reviews* 62: 97-135.
- Owens D.F. and Kriegstein A.R. (2002) Is there more to gaba than synaptic inhibition? *Nat Rev Neurosci.* 3: 715-727.
- Palmen S.J., van Engeland H., Hof P.R. and Schmitz C. (2004) Neuropathological findings in autism. *Brain.* 127: 2572-2583.
- Parker D., Söderberg C., Zotova E., Shupliakov O., Langel U., Bartfai T., Larhammar D., Brodin L. and Grillner S. (1998) Co-localized neuropeptide Y and GABA have complementary presynaptic effects on sensory synaptic transmission. *Eur J Neurosci.* 10: 2856-2870.
- Pallotto M., Nissant A., Fritschy J.M., Rudolph U., Sassoè-Pognetto M., Panzanelli P. and Lledo P.M. (2012) Early formation of GABAergic synapses governs the development of adult-born neurons in the olfactory bulb. *J Neurosci.* 32: 9103-9115.
- Partridge L. (2012) Diet and healthy aging. *N Engl J Med.* 367: 2550-2551.
- Patel A.B., de Graaf R.A., Mason G.F., Rothman D.L., Shulman R.G. and Behar K.L. (2005) The contribution of GABA to glutamate/glutamine cycling and energy metabolism in the rat cortex in vivo. *Proc Natl Acad Sci U S A* 102: 5588-5593.
- Patel AB, de Graaf RA, Martin DL, Battaglioli G, Behar KL. (2006) Evidence that GAD65 mediates increased GABA synthesis during intense neuronal activity in vivo. *J Neurochem.* 97: 385–96.
- Patisaul H.B. and Jefferson W. (2010) The pros and cons of phytoestrogens. *Front Neuroendocrinol.* 31: 400-419.



- Paul S.M. and Purdy R.H. (1992) Neuroactive steroids. *FASEB J.* 6: 2311-2322.
- Pavese J.M., Farmer R.L. and Bergan R.C. (2010) Inhibition of cancer cell invasion and metastasis by genistein. *Cancer Metastasis Rev.* 29: 465-482.
- Penatti C.A., Davis M.C., Porter D.M. and Henderson L.P. (2010) Altered GABAA receptor-mediated synaptic transmission disrupts the firing of gonadotropin-releasing hormone neurons in male mice under conditions that mimic steroid abuse. *J Neurosci.* 30: 6497-506.
- Peng L., Hertz L., Huang R., Sonnewald U., Petersen S.B. and Westerngaard N. (1993) Utilization of glutamine and of TCA cycle constituents as precursors for transmitter glutamate and GABA. *Dev Neurosci.* 15: 367-377.
- Pesold C. and Treit D. (1995) The central and basolateral amygdala differentially mediate the anxiolytic effects of benzodiazepines. *Brain Res* 671: 213-221.
- Pereno G.L., Balaszczuk V. and Beltramino C.A. (2011) Detection of conspecific pheromones elicits fos expression in GABA and calcium-binding cells of the rat vomeronasal system-medial extended amygdala. *J. Physiol. Biochem.* 67: 71.
- Petty F. (1995) GABA and mood disorders: a brief review and hypothesis. *J Affect Disord.* 34: 275-281.
- Petty F., Kramer G.L., Dunnam D. and Rush A.J. (1990) Plasma GABA in mood disorders. *Psychopharmacol Bull.* 26: 157-161.
- Petty F. and Sherman A.D. (1984) Plasma GABA levels in psychiatric illness. *J Affect Disord.* 6:131-138.
- Pierson R.C., Lyons A.M. and Greenfield L.J. Jr. (2005) Gonadal steroids regulate GABAA receptor subunit mRNA expression in NT2-N neurons. *Brain Res Mol Brain Res.* 138: 105-115.
- Pick H., Etter S., Baud O., Schmauder R., Bordoli L., Schwede T. and Vogel H. (2009) Dual activities of odorants on olfactory and nuclear hormone receptors. *J Biol Chem.* 284: 30547-30555.
- Pinna G., Agis-Balboa R.C., Pibiri F., Nelson M., Guidotti A. and Costa E. (2008) Neurosteroid biosynthesis regulates sexually dimorphic fear and aggressive behavior in mice. *Neurochem Res.* 33: 1990-2007.
- Pinal C.S., Cortessis V. and Tobin A.J. (1997) Multiple elements regulate GAD65 transcription. *Dev Neurosci.* 19: 465-475.

- Pinel J.P., and Treit D. (1978) Burying as a defensive response in rats. *J Comp Physiol. Psychol.* 92: 708-712.
- Pirker S., Schwarzer C., Wieselthaler A., Sieghart W. and Sperk G. (2000) GABA(A) receptors: immunocytochemical distribution of 13 subunits in the adult rat brain. *Neuroscience.* 101: 815-850.
- Plante D.T. and Winkelman J.W. Sleep disturbance in bipolar disorder: therapeutic implications. *Am J Psychiatry.* 165: 830-843.
- Pizzarelli R. and Cherubini E. (2011) Alterations of GABAergic Signaling in Autism Spectrum Disorders. *Neural Plasticity:* 297153.
- Polepalli JS, Sullivan RK, Yanagawa Y, Sah P (2010). A specific class of interneuron mediates inhibitory plasticity in the lateral amygdala. *J Neurosci.* 30: 14619-14629.
- Powers J.B., Newman S.W. and Bergondy M.L. (1987) MPOA and BNST lesions in male Syrian hamsters: differential effects on copulatory and chemoinvestigatory behaviors. *Behav Brain Res.* 23: 181-195.
- Pritchett D., Wulff K., Oliver P.L., Bannerman D.M., Davies K.E., Harrison P.J., Peirson S.N. and Foster R.G. (2012) Evaluating the links between schizophrenia and sleep and circadian rhythm disruption. *J Neural Transm.* 119:1061-1075.
- Prut L, Prenosil G, Willadt S, Vogt K, Fritschy JM and Crestani F (2010) A reduction in hippocampal GABAA receptor alpha5 subunits disrupts the memory for location of objects in mice. *Genes Brain Behav:* 9: 478-88.
- Pugazhendhi D., Watson K.A., Mills S., Botting N., Pope G.S. and Darbre P.D. (2008) Effect of sulphation on the oestrogen agonist activity of the phytoestrogens genistein and daidzein in MCF-7 human breast cancer cells. *J Endocrinol.* 197: 503-515.
- Pytel M., Wo'jtowicz T., Mercik K. and Sarto I. (2007) 17 b-estradiol modulates GABAergic synaptic transmission and tonic currents during development in vitro. *Neuropharmacology* 52:1342e1353.
- Pytel M., Wójtowicz T., Mercik K., Sarto-Jackson I., Sieghart W., Ikonomidou C., and Mozrzymas J.W. (2007) 17beta-estradiol modulates GABAergic synaptic transmission and tonic currents during development in vitro. *Neuropharmacology.* 52: 1342-1353.

- Qin H.Y., Elliott J.F., Lakey J.R., Rajotte R.V. and Singh B.. (1998) Endogenous immune response to glutamic acid decarboxylase (GAD67) in NOD mice is modulated by adjuvant immunotherapy. *J Autoimmun.* 11: 591-601.
- Quaglino E., Giustetto M., Panzanelli P., Cantino D., Fasolo A. and Sassoè-Pognetto M. (1999) Immunocytochemical localization of glutamate and gamma-aminobutyric acid in the accessory olfactory bulb of the rat. *J Comp Neurol.* 408: 61-72.
- Raafat A., Strizzi L., Lashin K., Ginsburg E., McCurdy D., Salomon D., Smith G.H., Medina D. and Callahan R. (2012) Effects of age and parity on mammary gland lesions and progenitor cells in the FVB/N-RC mice. *PLoS One.* 7: e43624.
- Rabinak CA and Maren S (2008). Associative structure of fear memory after basolateral amygdala lesions in rats. *Behav Neurosci.* 122: 1284-1294.
- Rafi M.M., Rosen R.T., Vassil A., Ho C.T., Zhang H., Ghai G., Lambert G. and DiPaola R.S. (2000) Modulation of bcl-2 and cytotoxicity by licochalcone-A, a novel estrogenic flavonoid. *Anticancer Res.* 20: 2653-2658.
- Rakesh G., Rao N.P., Venkatasubramanian G., Behere R.V., Varambally S., and Gangadhar B.N. (2011) Treatment with phytoestrogens for depressive symptoms in late-onset schizophrenia: a case report. *Prim Care Companion CNS Disord.* 13: PCC.10101123
- Ranich T., Bhathena S.J., and Velasquez M.T. (2001) Protective effects of dietary phytoestrogens in chronic renal disease. *J Ren Nutr.* 11: 183-193.
- Rapin I. (1991) Autistic children: diagnosis and clinical features. *Pediatrics.* 87:751-760.
- Rapin I. and Katzman R. (1998) Neurobiology of autism. *Ann Neurol.* 43:7-14.
- Rau V., Iyer S.V., Oh I., Chandra D., Harrison N., Eger E.I. 2nd, Fanselow M.S., Homanics G.E. and Sonner J.M. (2009) Gamma-aminobutyric acid type A receptor alpha 4 subunit knockout mice are resistant to the amnestic effect of isoflurane. *Anesth Analg.* 109: 1816-1822.
- Restrepo D., Arellano J., Oliva A.M., Schaefer M.L. and Lin W. (2004) Emerging views on the distinct but related roles of the main and accessory olfactory systems in responsiveness to chemosensory signals in mice. *Horm Behav.* 46: 247-256.

- Rice S. and Whitehead S.A. (2006) Phytoestrogens and breast cancer--promoters or protectors? *Endocr Relat Cancer*. 13: 995-1015.
- Richter K., Wolf G. and Engelmann M. (2005) Social recognition memory requires two stages of protein synthesis in mice. *Learn Mem*. 12: 407-413.
- Riecher-Roessler A. and de Geyter C. (2007) The forthcoming role of treatment with oestrogens in mental health. *Swiss Med Wkly*.137: 565–572.
- Rimvall K. and Martin D.L. (1994) The level of GAD67 protein is highly sensitive to small increases in intraneuronal gamma-aminobutyric acid levels. *J Neurochem*. 62: 1375-1381.
- Roberts D., Veeramachaneni D.N., Schlaff W.D. and Awoniyi C.A. (2000) Effects of chronic dietary exposure to genistein, a phytoestrogen, during various stages of stages of development on reproductive hormones and spermatogenesis in rats. *Endocrine*. 13: 281-286.
- Rodrigues S.M., Schafe G.E. and LeDoux J.E. (2004) Molecular mechanisms underlying emotional learning and memory in the lateral amygdala. *Neuron*. 44: 75-91.
- Rodriguez Manzanares P.A., Isoardi N.A., Carrer H.F. and Molina V.A. (2005). Previous stress facilitates fear memory, attenuates GABAergic inhibition, and increases synaptic plasticity in the rat basolateral amygdala. *J Neurosci*. 25: 8725-8734.
- Rossetti S., Corlazzoli F., Gregorski A., Azmi N.H. and Sacchi N. (2012) Identification of an estrogen-regulated circadian mechanism necessary for breast acinar morphogenesis. *Cell Cycle*. 11: 3691-3700.
- Roth F.C. and Draguhn A. (2012) GABA metabolism, and transport: effects on synaptic efficacy. *Neural Plast*. :805830.
- Roy-Byrne P.P., Cowley D.S., Greenblatt D.J., Shader R.I. and Hommer D. (1990) Reduced benzodiazepine sensitivity in panic disorder. *Arch Gen Psychiatry*. 47: 534-538.
- Roy-Byrne P., Wingerson D.K., Radant A., Greenblatt D.J. and Cowley D.S. (1996) Reduced benzodiazepine sensitivity in patients with panic disorder: comparison with patients with obsessive-compulsive disorder and normal subjects. *Am J Psychiatry* 153: 1444–1449

- Roy-Byrne P., Wingerson D.K., Radant A., Greenblatt D.J. and Cowley D.S. (1996) Reduced benzodiazepine sensitivity in patients with panic disorder: comparison with patients with obsessive-compulsive disorder and normal subjects. *Am J Psychiatry*. 153: 1444-1449.
- Rudick C.N., Gibbs R.B. and Woolley C.S. (2003) A role for the basal forebrain cholinergic system in estrogen-induced disinhibition of hippocampal pyramidal cells. *J Neurosci*. 23: 4479-4490.
- Rudick C.N., Woolley C.S. (2001) Estrogen regulates functional inhibition of hippocampal CA1 pyramidal cells in the adult female rat. *J Neurosci*. 21: 6532-6543.
- Rudick C.N. and Woolley C.S. (2003) Selective estrogen receptor modulators regulate phasic activation of hippocampal CA1 pyramidal cells by estrogen. *Endocrinology*. 144: 179-187.
- Rudolph U. and Möhler H. (2004) Analysis of GABAA receptor function and dissection of the pharmacology of benzodiazepines and general anesthetics through mouse genetics. *Annu Rev Pharmacol Toxicol*. 44: 475-498.
- Ryan B.C., Young N.B., Moy S.S. and Crawley J.N. (2008) Olfactory cues are sufficient to elicit social approach behaviors but not social transmission of food preference in C57BL/6J mice. *Behav Brain Res*. 193: 235-422.
- Saito K., Kakizaki T., Hayashi R., Nishimaru H., Furukawa T., Nakazato Y., Takamori S., Ebihara S., Uematsu M., Mishina M., Miyazaki J., Yokoyama M., Konishi S., Inoue K., Fukuda A., Fukumoto M., Nakamura K., Obata K. and Yanagawa Y. (2010) The physiological roles of vesicular GABA transporter during embryonic development: a study using knockout mice. *Mol Brain*. 3: 40.
- Sandnabba N.K., Lagerspetz K.M. and Jensen E. (1994) Effects of testosterone exposure and fighting experience on the aggressive behavior of female and male mice selectively bred for intermale aggression. *Horm Behav*. 28: 219-231
- Santagati S., Melcangi R.C., Celotti F., Martini L. and Maggi A. (1994) Estrogen receptor is expressed in different types of glial cells in culture. *J Neurochem*. 63: 2058-2064.
- Sangha S., Narayanan R.T., Bergado-Acosta J.R., Stork O., Seidenbecher T. and Pape H.C. (2009). Deficiency of the 65 kDa isoform of glutamic acid decarboxylase impairs extinction of cued but not contextual fear memory. *J Neurosci*. 29: 15713-15720.

- Santini E., Muller R.U. and Quirk G.J. (2001) Consolidation of extinction learning involves transfer from NMDA-independent to NMDA-dependent memory. *J Neurosci* 21: 9009–9017.
- Sar M., Sahu A., Crowley W.R. and Kalra S.P. (1990) Localization of neuropeptide-Y immunoreactivity in estradiol-concentrating cells in the hypothalamus. *Endocrinology*. 127: 2752-2756.
- Sarajari S, and Oblinger MM.(2010) Estrogen effects on pain sensitivity and neuropeptide expression in rat sensory neurons. *Exp Neurol*. 224(1):163-
- Saridaki E., Carter D.A. and Lightman S.L. (1989) gamma-Aminobutyric acid regulation of neurohypophysial hormone secretion in male and female rats. *J Endocrinol*. 121: 343-349.
- Schafe G.E., Doyère V. and LeDoux J.E. (2005) Tracking the fear engram: the lateral amygdala is an essential locus of fear memory storage. *J Neurosci*. 25: 10010-10014.
- Scheel-Krüger J. and Petersen E.N. (1982) Anticonflict effect of the benzodiazepines mediated by a GABAergic mechanism in the amygdala. *Eur J Pharmacol*. 82: 115-116.
- Schnorbusch K., Lembrechts R., Pintelon I., Timmermans J.P., Brouns I. and Adriaensen D. (2013) GABAergic signaling in the pulmonary neuroepithelial body microenvironment: functional imaging in GAD67-GFP mice. *Histochem Cell Biol*. 140: 549-566.
- Schousboe A., Westergaard N., Sonnewald U., Petersen S.B., Huang R. and Peng L. (1993) Glutamate and glutamine metabolism and compartmentation in astrocytes. *Dev Neurosci* 15: 359–366.
- Schultz R.T. (2005) Developmental deficits in social perception in autism: the role of the amygdala and fusiform face areas. *Int. J. Devl Neuroscience*. 23: 125–141.
- Seeman M.V. and Lang M. (1990) The role of estrogens in schizophrenia gender differences. *Schizophr Bull*. 16: 185-194.
- Setchell K.D. and Cole S.J. (2006). Method of defining equol-producer status and its frequency among vegetarians. *J. Nutri*. 136: 2188–2193.
- Setchell K.D. (1998) Phytoestrogens: the biochemistry, physiology, and implications for human health of soy isoflavones. *Am J Clin Nutr*. 68:1 333S-1346S.

Setchell KDR and Cassidy A (1999). Dietary isoflavones – biological effects and relevance to human health. *J Nutr.* 129: 758–767.

Sheikh S.N., Martin S.B. and Martin D.L. (1999) Regional distribution and relative amounts of glutamate decarboxylase isoforms in rat and mouse brain. *Neurochem Int.* 35: 73-80.

Shen H., Gong Q.H., Yuan M. and Smith S.S. (2005) Short term steroid treatment increases delta GABA(A) receptors: modulating gain and maintaining the tone. *Trends in Neurosciences* 27: 262-269.

Sherwin B.B. (2003) Estrogen and cognitive functioning in women. *Endocr Rev.* 2003 24: 133-151

Sfakianos J., Coward L., Kirk M. and Barnes S. (1997) Intestinal uptake and biliary excretion of the isoflavone genistein in rats. *J Nutr.* 127: 1260-1268.

Shin L.M. and Liberzon I. (2010) The neurocircuitry of fear, stress, and anxiety disorders. *Neuropsychopharmacology.* 35: 169-191.

Shi Y., Veit B. and Baekkeskov S. (1994) Amino acid residues 24-31 but not palmitoylation of cysteines 30 and 45 are required for membrane anchoring of glutamic acid decarboxylase, GAD65. *J Cell Biol.* 124: 927-934.

Shughrue P, Lane M, Scrimo P, Merchenthaler I . (1998) Comparative distribution of estrogen receptor-a (ERa) and b (ERb) mRNA in the rat pituitary, gonad, and reproductive tract, *Steroids* 63: –504.

Shughrue P.J., Lane M.V. and Merchenthaler I. (1999) Biologically active estrogen receptor-beta: evidence from in vivo autoradiographic studies with estrogen receptor alpha-knockout mice. *Endocrinology.* 140: 2613-2620.

Sichel D.A., Cohen L.S., Robertson L.M., Rutenberg A. and Rosenbaum J.F. (1995) Prophylactic estrogen in recurrent postpartum affective disorder. *Biol Psychiatry.* 38:814-818.

Sieghart W. and Sperk G. (2002) Subunit composition, distribution and function of GABA(A) receptor subtypes. *Curr Top Med Chem.* 2: 795–716.

Silverman J.L., Yang M., Lord C. and Crawley J.N. (2010) Behavioural phenotyping assays for mouse models of autism. *Nat Rev Neurosci.* 11: 490-502.

- Sloviter R.S., Dichter M.A., Rachinsky T.L., Dean E., Goodman J.H., Sollas A.L. and Martin D.L. (1996) Basal expression and induction of glutamate decarboxylase and GABA in excitatory granule cells of the rat and monkey hippocampal dentate gyrus. *J Comp Neurol.* 373: 593-618.
- Soghomonian JJ and Martin DL. (1998) Two isoforms of glutamate decarboxylase: why? *Trends Pharmacol Sci.* 19: 500-505.
- Solimena M, Aggujaro D, Muntzel C, Dirx R, Butler M, De Camilli P, Hayday A. (1993) Association of GAD-65, but not of GAD-67, with the Golgi complex of transfected Chinese hamster ovary cells mediated by the N-terminal region. *Proc Natl Acad Sci U S A.* 90: 3073-7.
- Somogyi P., and Klausberger T. (2005) Defined types of cortical interneurone structure space and spike timing in the hippocampus *J. Physiol.* 562: 9–26
- Somponpun S. and Sladek C.D. (2002) Role of estrogen receptor-beta in regulation of vasopressin and oxytocin release in vitro. *Endocrinology.* 143: 2899-2904.
- Sorwell K.G., Wesson D.W. and Baum M.J. (2008) Sexually dimorphic enhancement by estradiol of male urinary odor detection thresholds in mice. *Behav Neurosci.* 122: 788-793.
- Spencer KM, Nestor PG, Niznikiewicz MA, Salisbury DF, Shenton ME, McCarley RW. (2003) Abnormal neural synchrony in schizophrenia. *J Neurosci.* 23: 7407–11
- Spitzer N.C., Borodinsky L.N. and Root C.M. (2005). Homeostatic activity-dependent paradigm for neurotransmitter specification. *Cell Calcium.* 37: 417-423.
- Stewart L.R., Hall A.L., Kang S.H., Shaw C.A. and Beaudet A.L. (2011) High frequency of known copy number abnormalities and maternal duplication 15q11-q13 in patients with combined schizophrenia and epilepsy. *BMC Med Genet.* 12: 154.
- Stork O., Ji F.Y., Kaneko K., Stork S., Yoshinobu Y. and Moriya T. (2000). Postnatal development of a GABA deficit and disturbance of neural functions in mice lacking GAD65. *Brain Res.* 865: 45–58.
- Stork O, Ji FY, Obata K (2002) Reduction of extracellular GABA in the mouse amygdala during and following confrontation with a conditioned fear stimulus. *Neurosci Lett.* 327: 138-142.



- Stork O., Yamanaka H., Stork S., Kume N. and Obata K. (2003). Altered conditioned fear behavior in glutamate decarboxylase 65 null mutant mice. *Genes Brain Behav.* 2: 65-70.
- Stowers L. and Marton T. (2005) What is a pheromone? Mammalian pheromones reconsidered. *Neuron.* 46: 699.
- Stowers L, Holy TE, Meister M, Dulac C and Koentges G. (2002) Loss of sex discrimination and male-male aggression in mice deficient for TRP2. *Science.* 295(5559):1493-1500.
- Straub R.E., Lipska B.K., Egan M.F., Goldberg T.E., Callicott J.H., Mayhew M.B., Vakkalanka R.K., Kolachana B.S., Kleinman J.E. and Weinberger D.R. (2007) Allelic variation in GAD1 (GAD67) is associated with schizophrenia and influences cortical function and gene expression. *Mol. Psychiatry* 12: 854-869.
- Szapiro G., Vianna, M.R., McGaugh J.L., Medina J.H. and Izquierdo I. (2003) The role of NMDA glutamate receptors, PKA, MAPK, and CAMKII in the hippocampus in extinction of conditioned fear. *Hippocampus* 13: 53-58.
- Szabó G., Katarova Z., Körtvély E., Greenspan R.J. and Urbán Z. (1996) Structure and the promoter region of the mouse gene encoding the 67-kD form of glutamic acid decarboxylase. *DNA Cell Biol.* 15: 1081-1091.
- Takagi M. and Yamamoto C. (1981) The long lasting inhibition recorded in vitro from the lateral nucleus of the amygdala. *Brain Res.* 206: 474-478.
- Tamamaki N. and Tomioka R. (2010) Long-Range GABAergic Connections Distributed throughout the Neocortex and their Possible Function. *Front Neurosci* 4: 202.
- Tamamaki N., Yanagawa Y., Tomioka R., Miyazaki J., Obata K. and Kaneko T. (2003). Green fluorescent protein expression and colocalization with calretinin, parvalbumin, and somatostatin in the GAD67-GFP knock-in mouse. *J Comp Neurol.* 467: 60-79.
- Tang A.C., Nakazawa M., Romeo R.D., Reeb B.C., Sisti H. and McEwen B.S. (2005) Effects of long-term estrogen replacement on social investigation and social memory in ovariectomized C57BL/6 mice. *Horm Behav.* 47: 350-357.
- Tobin V.A., Noack J., Bishop V.R., Duszkiwicz A.J., Engelmann M., Meddle S.L. and Ludwig M. (2010) Expression of early growth response protein 1 in vasopressin

neurones of the rat anterior olfactory nucleus following social odour exposure. *J Physiol.* 588: 4705-4717.

Tobler I., Kopp C., Deboer T. and Rudolph U. (2001) Diazepam-induced changes in sleep: role of the alpha 1 GABA(A) receptor subtype. *Proc Natl Acad Sci U S A.* 98: 6464-6469.

Thomas A., Burant A., Bui N., Graham D., Yuva-Paylor L.A. and Paylor R. (2009) Marble burying reflects a repetitive and perseverative behavior more than novelty-induced anxiety. *Psychopharmacology (Berl).* 204: 361-373.

Thompson M., Weickert C.S., Wyatt E. and Webster M.J. (2009) Decreased glutamic acid decarboxylase<sub>67</sub> mRNA expression in multiple brain areas of patients with schizophrenia and mood disorders. *J. Psychiat. Res.* 43: 970.

Treiman DM. (2001) GABAergic mechanisms in epilepsy. *Epilepsia.* 42:8-12.

Tremolizzo L., Doueiri M.S., Dong E., Grayson D.R., Davis J., Pinna G., Tueting P., Rodriquez-Menendez V., Costa E. and Guidotti A.,(2005) Valproate corrects the schizophrenia-like epigenetic behavioral modifications induced by methionine in mice. *Bio. Psychiatry.* 1: 500.

Tremolizzo L., Carbonj G., Ruzicka W.B., Mitchell C.P., Sugaya I., Tueting P., Sharma R., Grayson D.R., Costa E. and Guidotti A. (2002) An epigenetic mouse model for molecular and behavioral neuropathologies related to schizophrenia vulnerability. *Proc Natl Acad Sci USA* 99: 17095-17100.

Truitt W.A., Johnson P.L., Dietrich A.D., Fitz S.D. and Shekhar A. (2009) Anxiety-like behavior is modulated by a discrete subpopulation of interneurons in the basolateral amygdala. *Neuroscience.* 160: 284-294.

Uusi-Oukari M. and Korpi E.R. (2010) Regulation of GABA(A) receptor subunit expression by pharmacological agents. *Pharmacol Rev.* 62: 97-135.

Uchida T., Oki Y., Yanagawa Y. and Fukuda A. (2011). A heterozygous deletion in the glutamate decarboxylase 67 gene enhance maternal and fetal stress vulnerability. *Neurosci Res.* 69: 276-282.

Uchida H., Ogawa S., Harada M., Matushita M., Iwata M., Sakuma Y. and Parhar I.S. (2005) The olfactory organ modulates gonadotropin-releasing hormone types and nest-building behavior in the tilapia *Oreochromis niloticus*. *J Neurobiol.* 65: 1.

Vaiva G., Boss V., Ducrocq F., Fontaine M., Devos P., Brunet A., Laffargue P., Goudemand M. and Thomas P. (2006) Relationship between posttrauma GABA plasma levels and PTSD at 1-year follow-up. *Am J Psychiatry*.163: 1446-1448.

Vaiva G., Thomas P., Ducrocq F., Fontaine M., Boss V., Devos P., Rasclé C., Cottencin O., Brunet A., Laffargue P. and Goudemand M. (2004) Low posttrauma GABA plasma levels as a predictive factor in the development of acute posttraumatic stress disorder. *Biol Psychiatry*. 55: 250-254.

Van Bogaert M., Oosting R., Toth M., Groenink L., van Oorschot R. and Olivier B. (2006) Effects of genetic background and null mutation of 5-HT1A receptors on basal and stress-induced body temperature: modulation by serotonergic and GABAergic drugs. *Eur J Pharmacol*. 550: 84-90.

VanGuilder H.D., Vrana K.E. and Freeman W.M. (2008) Twenty-five years of quantitative PCR for gene expression analysis. *Biotechniques*. 44: 619-626

Veldic M., Guidotti A., Maloku E., Davis J.M. and Costa E. (2005) In psychosis, cortical interneurons overexpress DNA-methyltransferase 1. *Proc. Natl. Acad. Sci. USA*. 102: 2152-2157.

Vergaño-Vera E., Yusta-Boyo M.J., de Castro F., Bernad A., de Pablo F. and Vicario-Abejón C. (2006) Generation of GABAergic and dopaminergic interneurons from endogenous embryonic olfactory bulb precursor cells. *Development*. 133: 4367-4379.

Vida B., Hrabovszky E., Kalamatianos T., Coen C.W., Liposits Z., and Kalló I. (2008) Oestrogen receptor alpha and beta immunoreactive cells in the suprachiasmatic nucleus of mice: distribution, sex differences and regulation by gonadal hormones. *J Neuroendocrinol*. 20: 1270-1277.

Vierk R., Brandt N. and Rune G.M. (2014) Hippocampal estradiol synthesis and its significance for hippocampal synaptic stability in male and female animals. *Neuroscience*. 274: 24-32.

Volk D.W., Austin M.C., Pierri J.N., Sampson A.R. and Lewis D.A. (2000) Decreased glutamic acid decarboxylase67 messenger RNA expression in a subset of prefrontal cortical gamma-aminobutyric acid neurons in subjects with schizophrenia. *Arch Gen Psychiatry*. 57: 237-245.

Wacker D.W., Tobin V.A., Noack J., Bhishop V.R., Duszkiewicz A.J., Engelmann M., Meddle S.L., Ludwig M., 2010. Expression of early growth response protein 1 in vasopressin neurones of the rat anterior olfactory nucleus following social odour exposure. *J. Physiol.* 588: 4705-4717.

Wagner EJ, Ronnekleiv OK, Bosch MA and Kelly MJ (2001). Estrogen biphasically modifies hypothalamic GABAergic function concomitantly with negative and positive control of luteinizing hormone release. *J Neurosci.* 21: 2085-2093.

Walker D.L. and Davis M. (2002) The role of amygdala glutamate receptors in fear learning, fear-potentiated startle, and extinction. *Pharmacol Biochem Behav.* 271: 379-392.

Walls A.B., Eyjolfsson E.M., Smeland O.B., Nilsen L.H., Schousboe I., Schousboe A., Sonnewald U. and Waagepetersen H.S. (2011) Knockout of GAD65 has major impact on synaptic GABA synthesized from astrocyte-derived glutamine. *J Cereb Blood Flow Metab.* 31: 494-503.

Wang Y., Takayanagi Y., Onaka T., 2013 Effects of medial amygdala lesions upon social behavior in mice. *Advances in Cognitive Neurodynamics* :753-757

Wang Y., Kakizaki T., Sakagami H., Saito K., Ebihara S., Kato M., Hirabayashi M., Saito Y., Furuya N. and Yanagawa Y. (2009). Fluorescence labeling of both GABAergic and Glycinergic neurons in vesicular GABA transporter (VGAT-venus transgenic mouse. *Neuroscience* 164: 1031-1043.

Wassef A., Baker J. and Kochan L.D. (2003) GABA and schizophrenia: a review of basic science and clinical studies. *J Clin Psychopharmacol.* 23: 601-640.

Wasserman M.D., Chapman C.A., Milton K., Godgarten J.F., Witter D.J. and Ziegler T.E. (2012). Estrogenic plant consumption predicts red colobus monkey (*Procolobus rufomitratus*) hormonal state and behavior. *Horm Behav.* 62: 553-562.

Weber K.S., Setchell K.D.R., Stocco D.M. and Lepart E.D. (2001). Dietary soy-phytoestrogens decrease testosterone levels and prostate weight without altering LH, prostate 5 $\alpha$ -reductase or testicular steroidogenic acute regulatory peptide levels in adult male Sprague–Dawley rats. *J Endocrinol* 170: 591–599.

- Weiland N.G. (1992). Glutamic acid decarboxylase messenger ribonucleic acid is regulated by estradiol and progesterone in the hippocampus. *Endocrinology*. 131: 2697-2702.
- Wersinger S.R., Ginns E.L., O'Carroll A.M., Lolait S.J. and Young W.S. (2002) Vasopressin V1b receptor knockout reduces aggressive behavior in male mice. *Mol. Psychiatry*. 7: 975-984.
- Wersinger S.R., Sannen K., Villalba C., Lubahn D.B., Rissman E.F. and De Vries G.J. (1997) Masculine sexual behavior is disrupted in male and female mice lacking a functional estrogen receptor alpha gene. *Horm Behav* 32: 176–183.
- Wiltgen B.J., Sanders M.J., Anagnostaras S.G., Sage J.R. and Fanselow M.S. (2006) Context fear learning in the absence of the hippocampus. *J Neurosci*. 26: 5484-5491.
- Winslow J., Hastings N., Carter C., Harbaugh C. and Insel T. (1993) A role for central vasopressin in pair bonding in monogamous prairie voles. *Nature* 365: 545-548.
- Woolley C.S. and McEwen, B.S. (1993) Roles of estradiol and progesterone in regulation of hippocampal spine density during the estrous cycle in the rat. *J. Comp. Neurol*. 336: 293-306.
- Wu D., Jiang J.J., Fang R., Swinarski K. and Cui X. (2013) G protein-coupled estrogen receptor 1 expression in human vocal fold. *Laryngoscope*.123: 948-951.
- Wu M.V., Manoli D.S., Fraser E.J., Coats J.K., Tollkuhn J., Honda S., Harada N. and Shah N.M. (2009) Estrogen masculinizes neural pathways and sex-specific behaviors. *Cell*. 139: 61-72.
- Yanagawa Y., Kobayashi T., Kamei T., Ishii K., Nishijima M., Takaku A., Tamura S. (1997) Structure and alternative promoters of the mouse glutamic acid decarboxylase 67 gene. *Biochem J*. 326: 573-578.
- Yang S.H., Shi J., Day A.L. and Simpkins J.W. (2000) Estradiol exerts neuroprotective effects when administered after ischemic insult. *Stroke*. 31: 745-749.
- Yanowitch R. and Coccaro E.F. (2011) The neurochemistry of human aggression. *Adv Genet*. 75: 151-69.

- Yee B.K., Hauser J., Dolgov V.V., Keist R., Möhler H., Rudolph U., Feldon J. (2004) GABA receptors containing the alpha5 subunit mediate the trace effect in aversive and appetitive conditioning and extinction of conditioned fear. *Eur J Neurosci.* 20(7): 1928-1936.
- Yip J., Soghomonian J.J. and Blatt G.J. (2007) Decreased GAD67 mRNA levels in cerebellar Purkinje cells in autism: pathophysiological implications. *Acta Neuropathol.* 113: 559-68.
- Yip J., Soghomonian J.J. and Blatt G.J. (2009) Decreased GAD65 mRNA levels in select subpopulations of neurons in the cerebellar dentate nuclei in autism: an in situ hybridization study. *Autism Res.* 2: 50-59.
- Young A. and Sun Q.Q. (2009) GABAergic inhibitory interneurons in the posterior piriform cortex of the GAD67-GFP mouse. *Cereb Cortex.* 19: 3011-3029.
- Zarrow M.X., Gandelman R. and Denenberg V.H. (1971) Lack of nest building and maternal behavior in the mouse following olfactory bulb removal. *Horm and behave.* 2: 227-238.
- Zengin A., Nguyen A.D., Wong I.P., Zhang L., Enriquez R.F., Eisman J.A., Herzog H., Baldock P.A and Sainsbury A. (2013) Neuropeptide Y mediates the short-term hypometabolic effect of estrogen deficiency in mice. *Int J Obes (Lond).* 37: 390-398.
- Zhang J., Sun Y., Liu Y., Sun Y. and Liao D.J. (2002) Synergistic effects of androgen and estrogen on the mouse uterus and mammary gland. *Oncol Rep.* 12: 709-716.
- Zhang JI, Sun Y, Liu Y, Sun Y, Liao DJ.(2004) Synergistic effects of androgen and estrogen on the mouse uterus and mammary gland. *Oncol Rep.* 12: 709-716.
- Zhang J.Q., Cai W.Q., Zhou de S. and Su B.Y. (2002) Distribution and differences of estrogen receptor beta immunoreactivity in the brain of adult male and female rats. *Brain Res.* 935 : 73–80.
- Zhao C., Eisinger B. and Gammie S.C. (2013) Characterization of GABAergic neurons in the mouse lateral septum: a double fluorescence in situ hybridization and immunohistochemical study using tyramide signal amplification. *PLoS One.* 8:e73750.
- Zheleznova N.N., Sedelnikova A. and Weiss D.S. (2009) Function and modulation of  $\delta$ -containing GABAA receptors. *Psychoneuroendocrinology* 34SI: S67-73.

**KIRAN VEER KAUR SANDHU**

**Raiffeisenstrasse 23,  
39112 Magdeburg,  
Germany  
[Kv.sandhu7@gmail.com](mailto:Kv.sandhu7@gmail.com)  
+49-151-45475162**

**Education**

|  |                    |
|--|--------------------|
| <b>Doctor of Philosophy,</b><br>Neuroscience, Otto-von-Guericke University, Magdeburg, Germany | <b>(2014-2015)</b> |
| <b>Master of Research,</b><br>Neuroscience, University of Edinburgh, Edinburgh, U.K.           | <b>(2009)</b>      |
| <b>Master of Science,</b><br>Human Genetics, Guru Nanak Dev University, Amritsar, India        | <b>(2005)</b>      |
| <b>Bachelor of Science (Honors),</b><br>Botany, Delhi University, Delhi, India                 | <b>(2003)</b>      |

**Research Experience**

|   |                    |
|---|--------------------|
| <b>Neuroscience Program, Otto-Von-Guerik University, Magdeburg, Germany</b><br>Principal Investigator: Prof. Dr. Stork O.<br>To study the role of phytoestrogen on glutamatic acid decarboxylase (GAD) mediated behavior.                                       | <b>(2009-2014)</b> |
| <b>Division of Neuroscience, University of Edinburgh, Edinburgh, U.K.</b><br>Principal Investigator: Dr. Skehel P.<br>To study the role of 3'UTR in Arc localization and identifiication of protein binding region in 3'UTR mediating Arc nuclear localization. | <b>(2008-2007)</b> |
| <b>Institute of Genomics and Integrative Biology, Delhi, India</b><br>Princial Investigator: Dr. Kukreti R.<br>Pharmacogenomics studies of variation on schizophrenic patients in Indian population.  | <b>(2006)</b>      |
| <b>Department of Biotechnology, I.A.R.I., Delhi, India</b><br>Princial Investigators: Dr. Srinivasan P.<br>Isolation and molecular characterization of di carboxylate transport (dct) mutants if <i>Mesorhizobium ciceri</i> TAL620.                            | <b>(2004)</b>      |

**Memberships**

Society of Neuroscience (SFN)  
British Neuroscience Association (BNA)

**University Teaching Experience**

|   |                    |
|---|--------------------|
| <b>Neuroscience Program, Otto-Von-Guerik University, Magdeburg, Germany</b><br>Molecular biology course tutorial instructor for MSc./PhD. Neuroscience course | <b>(2012)</b>      |
| Supervised laboratory practical traning for MSc./PhD. Neuroscience course   | <b>(2010-2013)</b> |

### Publication list

**Sandhu K.V.**, Lang D., Mueller B., Nullmeier S., Yanagawa Y., Schwegler H. and Stork O. (2014) Glutamate decarboxylase 67 haplo deficiency impairs social behavior in mice. *Genes Brain and Behavior*. 13(4): 439-450.

**Sandhu K.V.**, Yanagawa Y. and Stork O. (2015) Transcriptional activation of glutamic acid decarboxylase in the amygdala by phytoestrogens. (in revision: *Journal of Neuroendocrinology*).

**Sandhu K.V.**, Yanagawa Y. and Stork O. (2015) Phytoestrogen impairs social behavior in C57Bl/6 male mice. (in Preparation).

Singh J., **Sandhu K.V.**, Shandilya G., Subrata K. D., Gopal M. and Singh A. (2012)  $\beta$ -Cyfluthrin Biodegradation Gene(s) are Present on 18.0 kb Plasmid of *Pseudomonas stutzeri*, (strain S1). *Indian J Agric Sci*. 82(10): 831-834.

Das SK, Gautam U.S., **Sandhu K.V.**, Bandyopadhyay S., Chakrabartty P.K. and Singh A. (2010) Mutation in the lysA gene impairs the symbiotic properties of *Mesorhizobium ciceri*. *Arch Microbiol*. 192(1): 69-77.

### Poster Presentation

**Sandhu K.**, Mueller B., Stork O. (2012) Phytoestrogen modulation of glutamate decarboxylase (GAD) expression in the amygdala and its effects on fear behavior in GAD67 mutant mice. *8<sup>th</sup> FENS Forum*, Barcelona, Spain.

**Sandhu K.**, Kochergin V., Albrecht A., Stork O. (2011) Phytoestrogen modulation of glutamate decarboxylase (gad) expression in the amygdala and its effects on fear behavior in gad67 mutant mice. *Society for Neuroscience*, Washington, USA.

**Sandhu K.**, Kochergin V., Albrecht A., Stork O. (2011) Phytoestrogen modulation of glutamate decarboxylase (gad) expression in the amygdala and its effects on fear behavior in gad67 mutant mice. *4<sup>th</sup> biennial Neurizons*, Göttingen, Germany.

**Sandhu K.**, Mueller B., Kochergin V., Albrecht A., Stork O. (2010) Phytoestrogen modulation of glutamate decarboxylase (gad) expression in the amygdala and its effects on fear behavior in gad67 mutant mice. *XII. Magdeburg International Neurobiological Symposium "Learning and Memory: Cellular and Systemic Views"*, Magdeburg, Germany.



## Appendix

### A.1. Reagents, solutions:

| <b>DNA loading buffer</b>  |       |
|----------------------------|-------|
| Bromophenol blue           | 0.25% |
| Xylene cyanol FF           | 0.25% |
| Ficoll in H <sub>2</sub> O | 15%   |

| <b>DMDC treatment of water</b>                |      |
|---|------|
| Dimethyldicarbonate in double distilled water | 0.1% |
| Stir for 3 hours autoclave                    |      |

| <b>Lysis buffer for tail cuts</b> |        |
|-----------------------------------|--------|
| Tris, pH 8.0                      | 50 mM  |
| NaCl                              | 100 mM |
| EDTA                              | 100 mM |
| SDS                               | 1%     |
| Tris, pH 8.0                      | 50 mM  |

| <b>Monosodium Phosphate Buffer</b> |  | <b>300 mL</b> |
|------------------------------------|--|---------------|
| Monosodium phosphate               |  | 7.19 g        |

| <b>4% Paraformaldehyde (PFA)</b> |  | <b>1.5 L</b> |
|----------------------------------|--|--------------|
| Paraformaldehyde                 |  | 60 g         |
| Phosphate buffer Saline (10x)    |  | 150 mL       |

| <b>10x Phosphate Buffer Saline (PBS) pH 7.4</b> |  | <b>1L</b> |
|---|--|-----------|
| Disodium Phosphate                              |  | 1.44 g    |
| Mono-potassium Phosphate                        |  | 0.24 g    |
| Potassium Chloride                              |  | 0.2 g     |
| Sodium Chloride                                 |  | 8 g       |

| <b>0.2 M Phosphate Buffer (PB)</b>                           |  | <b>1 L</b> |
|--|--|------------|
| Sodium phosphate dibasic<br>(Sigma Aldrich, Seelze, Germany) |  | 28.394 g   |

| <b>Tyrode Buffer</b> |  | <b>1 L</b> |
|----------------------|--|------------|
| Calcium Chloride     |  | 0.2 g      |
| Disodium Phosphate   |  | 0.05 g     |
| Glucose              |  | 1 g        |
| Magnesium Chloride   |  | 0.1 g      |
| Potassium Chloride   |  | 0.2 g      |
| Sodium bicarbonate   |  | 1 g        |
| Sodium Chloride      |  | 8 g        |

| <b>20x Tris Based Saline (TBS) (20x) pH 7.4</b> |  | <b>1 L</b> |
|---|--|------------|
| Sodium Chloride (3M)                            |  | 175.3 g    |
| Tris Hydro Chloride (1 M)                       |  | 121.4 g    |

| <b>50x TAE Buffer</b> |         |
|-----------------------|---------|
| Tris base             | 242 g   |
| Acetic acid           | 57,1 mL |
| 0.5 M EDTA, pH 8.0    | 100 mL  |

| <b>1x TE-Buffer</b> |       |
|---------------------|-------|
| EDTA, pH 8.0        | 1 mM  |
| Tris/HCl, pH 7.4    | 10 mM |

## A.2. Antibodies:

| <b>Primary Antibodies</b>   |   |
|-----------------------------|---|
| c-Fos                       | Rabbit polyclonal antibody, Cell signaling, Cat #2250, Frankfurt am Mainz, Germany. |
| GAD65                       | Rabbit polyclonal antibody, Abcam, Cat # ab49830, Cambridge, UK.                    |
| GAD67                       | Goat polyclonal antibody, Abcam, Cat # ab80589, Cambridge, UK.                      |
| DAPI                        | Cat # D9542, Sigma-Aldrich.   |
| <b>Secondary Antibodies</b> |   |
| Cy3 Streptavidin            | Anti rabbit goat serum, Tocris, Cat# 1000, Wiesbaden, Germany.                      |

### A.3. Real time expression assays

| Gene  | Species | Amplicon length (bp) | Company                | Assay         |
|-------|---------|----------------------|------------------------|---------------|
| GAPDH | Mouse   | 107                  | AB, Darmstadt, Germany | Mm99999915_g1 |
| PGK   | Mouse   | 60                   | AB, Darmstadt, Germany | Mm01225301_m1 |
| GAD65 | Mouse   | 99                   | AB, Darmstadt, Germany | Mm00484623_m1 |
| GAD67 | Mouse   | 66                   | AB, Darmstadt, Germany | Mm00725661_s1 |
| NPY   | Mouse   | 65                   | AB, Darmstadt, Germany | Mm00445771_m1 |
| SST   | Mouse   | 86                   | AB, Darmstadt, Germany | Mm00436671_m1 |

### A.4. DNA length standard:

DNA molecular weight marker VII, Roche diagnostics, Mannheim, Germany

### A.5. Kits

RNA extraction from the tissue: RNAeasy Plus Microkit (50), Cat # 74034, Qiagen, Duesseldorf, Germany.

Reverse transcription kit: Sensicript RT kit (200), Cat # 205213, Qiagen, Duesseldorf, Germany.

Protein quantification: DC protein Assay Bio rad Cat# 500-0116, Munich, Germany.

Testosterone ELISA: Testosterone Saliva ELISA, Cat # RE52631, IBL, Hamburg, Germany.

Estradiol ELISA: 17 $\beta$ -Estradiol Saliva ELISA, Cat # RE52641, IBL, Hamburg, Germany.

Vasopressin ELISA: Arg<sup>8</sup>-Vasopressin ELISA. Cat # ADI-900-017, Enzo Life Sciences, Lausanne, Switzerland

**A.6. Software**

| <b>Task</b>                    | <b>Software name</b>  |
|--------------------------------|---|
| Real time PCR                  | Step Software V.2.02, Version 2.0.2, Applied biosystems, Darmstadt, Germany |
| Agar gel quantification        | GeneSnap Software, Syngene , Cambridge, UK                                  |
| ELISA reading                  | Tecan infinite 200, Tecan® Austria GmbH, Groedig Austria                    |
| Fluorescence microscopy        | Application Suite V3 and Leica QWin V3, Wetzlar, Germany                    |
| Laser capture microscopy       | P.A.L.M Robot V4, Carl Zeiss MicroImaging GmbH, Bernried, Germany           |
| Statistics                     | SPSS statistics 22.0, Version V4, IBM, USA                                  |
| Image processing               | Adobe Photoshop C4, Adobe, California, USA                                  |
| Fear behavior measurement      | TSE system, Bad Homburg, Germany  |
| Behavior measurements          | Any-maze, Stoeltingn Co., Illinois, USA                                     |
| Home cage activity measurement | Home cage activity system Version HCA1.0, Pennsylvania, USA                 |

**A.7 Chemicals**

|                                     |                                |
|-------------------------------------|--------------------------------|
| Acetic Acid                         | Carl Roth, Karlsruhe, Germany  |
| Agarose                             | Sigma, Taufheim, Germany       |
| Bromophenol blue                    | Sigma, Taufheim, Germany       |
| Dimethyl dicarbonat (DMDC)          | Perkin-Elmer, Waltham, MA, USA |
| di-Nucleotide-Tri-Phosphate (dNTP)  | Sigma, Taufheim, Germany       |
| Ethylendiamintetraessigsäure (EDTA) | Carl Roth, Karlsruhe, Germany  |
| Ethanol 96%                         | Merck, Darmstadt, Germany      |
| Ethidium bromid                     | Carl Roth, Karlsruhe, Germany  |
| Isopropanol                         | Fluka, Neu-Ulm, Germany        |
| Methylbutane                        | Sigma, Taufheim, Germany       |
| Mineral oil                         | Carl Roth, Karlsruhe, Germany  |
| NaCl                                | Sigma, Taufheim, Germany       |

|                              |  |
|------------------------------|--|
| Poly-L-Lysine 0.1%           | Life technologies, Karlsruhe, Germany            |
| Custom primers GAD67         | Life technologies, Karlsruhe, Germany            |
| Custom primers GAD65         | Roche Diagnostics, Mannheim, Germany             |
| Proteinase K                 | Molecular BioProducts, San Diego, CA, USA        |
| RNase away                   | Serva, Heidelberg, Germany                       |
| Sodium-Dodecyl-Sulfate (SDS) | Sakura Finetek Europe, Zoetwerwoude, Netherlands |
| Sodium Azide                 | Carl Roth, Karlsruhe, Germany                    |
| Tissue Tek O.C.T. Compound   | Carl Roth, Karlsruhe, Germany                    |
| TRIS-hydrochloride           | Carl Roth, Karlsruhe, Germany                    |

## A.8. Instruments and consumables

### Animal care

|                              |  |
|------------------------------|--|
| Macrolon standard cages      | Ebeco, Castrop-Rauxel, Germany             |
| Ssniff R/M-H V-1534 and 1544 | Ssniff Spezialdiäten, Soest, Germany       |
| Lignocel BK 8/15             | J. Rettenmaier & Söhne, Rosenberg, Germany |

### Plastic ware

|                                     |   |
|-------------------------------------|---|
| Safe lock tubes (1.5 ml)            | Eppendorf, Hamburg, Germany             |
| MicroAmp Fast Reaction Tubes        | Applied Biosystems, Darmstadt, Germany  |
| MicroAmp 8-cap strip                | Applied Biosystems, Darmstadt, Germany  |
| MicroAmp Fast Optical 96-Well plate | Applied Biosystems, Darmstadt, Germany  |
| MicroAmp Optical Adhesiv Film       | Applied Biosystems, Darmstadt, Germany  |
| Micro tube 500 for LCM              | PALM, Bernried, Germany                 |
| Falcon tube 50 ml                   | Greiner Bio-one, Frickenhausen, Germany |
| Object slide box                    | Carl Roth, Karlsruhe, Germany           |

**Glass ware**

|                        |                               |
|------------------------|-------------------------------|
| Glass bottles          | Carl Roth, Karlsruhe, Germany |
| Erlenmeyer flasks      | Carl Roth, Karlsruhe, Germany |
| Beaker                 | Carl Roth, Karlsruhe, Germany |
| Graduated cylinders    | Carl Roth, Karlsruhe, Germany |
| Staining cuvettes      | Carl Roth, Karlsruhe, Germany |
| Slide holder           | Carl Roth, Karlsruhe, Germany |
| MembraneSlides 1.0 PEN | PALM, Bernried, Germany       |

**Pipettes**

|                          |                          |
|--------------------------|--------------------------|
| Pipettes                 | Brand, Wertheim, Germany |
| Pipette tips             | Brand, Wertheim, Germany |
| Pipette tips with filter | Brand, Wertheim, Germany |

**Freezers & Fridge**

|                  |   |
|------------------|---|
| Liebherr KU 2407 | Liebherr Hausgeräte, Ochsenhausen, Germany      |
| Liebherr GU 4506 | Liebherr Hausgeräte, Ochsenhausen, Germany      |
| Sanyo Ultra Low  | Ewald Innovationstechnik, Bad Nenndorf, Germany |

**Scales**

|                   |                                  |
|-------------------|----------------------------------|
| Sartorius TE 1535 | Sartorius AG, Göttingen, Germany |
| Sartorius TE 212  | Sartorius AG, Göttingen, Germany |
| Sartorius TE 2101 | Sartorius AG, Göttingen, Germany |

**Centrifuges**

|                 |                                       |
|-----------------|---------------------------------------|
| Centrifuge 5424 | Eppendorf, Hamburg, Germany           |
| Centrifuge 5430 | Eppendorf, Hamburg, Germany           |
| VWR Galaxy Mini | VWR International, Darmstadt, Germany |

**Autoclave**

|              |   |
|--------------|---|
| Systec DB-23 | Systec Labortechnik, Wetztenberg, Germany |
|--------------|---|

**Oven**

|             |                             |
|-------------|-----------------------------|
| Binder FP53 | Binder, Tuttlingen, Germany |
|-------------|-----------------------------|

**pH meter**

inoLab pH720

WTW, Weilheim, Germany

**Magnetic Stirrer**

IKA RET basic

IKA-Werke, Staufen, Germany

magnetic stir bar

Brand, Wertheim, Germany

**Rotor incubator**

Hybrid 2000

H. Saur Laborbedarf, Reutlingen, Germany

**PCR Hood**

Captair bio

Erlab, Köln, Germany

**Thermocycler**

Veriti Thermal Cycler

Applied Biosystems, Darmstadt, Germany

**Microwave**

Clatronic MWG 746 H

Clatronic International, Kempen, Germany

**Gel electrophoresis system**

AGT3 & Maxi-VG

VWR International, Darmstadt, Germany

**Gel documentation system**

InGenius LHR

Syngene, Cambridge, UK

**Cryostat**

CM 1950

Leica, Nussloch, Germany

**Hot plate**

Medite OTS 40.2530

Medite, Burgdorf, Germany

**Real-time-PCR**

AbiPrism 7000 sequence detection system

Applied Biosystems, Darmstadt, Germany

**Fear Conditioning Apparatus**

TSE Fear Conditioning System

TSE, Bad Homburg, Germany

**Others**

Lab clock

Carl Roth, Karlsruhe, Germany

Aluminum foil

Carl Roth, Karlsruhe, Germany

**Laser capture microdissection system**

PALM MicroBeam

PALM, Bernried, Germany

**Fluorescence microscope**

Leica 6000DMi Epifluorescence

Leica Microsystems, Wetzlar, Germany

Microscope

**Strains**

C57 Bl/6J BomTac

M&B Taconic, Berlin, Germany