

Substantiating the Jet Agitator Parameters for Dredgers

Andrii Bondarenko¹, Viktor Kukhar¹ and Assel Nurmanova²

¹*Department of Engineering and Design in Machinery Industry, Dnipro University of Technology,
DmytroYavornytsky Avenue 19, 49005 Dnipro, Ukraine*

²*Satbayev University, Satpaev Str. 22a, 050013 Almaty, Kazakhstan
bondarenko.a.o@nmu.one, kukhar.v.yu@nmu.one, a.nurmanova@satbayev.university*

Keywords: Jet Agitator, Mathematical Model, Dredger, Underwater Face.

Abstract: The paper presents the results of a theoretical study concerning jet flow-loose ground interaction in the underwater face. A mathematical model was developed to establish the values of a sufficient number of geometric parameters to develop the contact surface between the turbulent jetting with the ground being washed out. The adequacy of the developed mathematical model was confirmed while preparing and conducting a series of laboratory experiments aimed at granular soil jet agitating; the designed laboratory facility was applied. Numerical values of empiric coefficients were derived, and the experimental data have been processed statistically. The effectiveness of the use of jet agitators in underwater mining and construction works has been confirmed by the results of theoretical and experimental studies obtained in this work. The developed mathematical model to calculate jet agitators has been tested while developing designs of such ejector dredgers as 3HC 630-90 and 3HC 300-120, and while modernizing soil suction heads of CCB 500/440, M3-16Э, M3-8, M3-11, Pechora, and ГИИИ-11 dredgers.

1 INTRODUCTION

Practices of using floating dredgers to mine underwater or waterlogged deposits of ore and nonmetallic sands suggest that excavation intensification can be achieved by using rationally designed jet agitators [1, 2]. The essence of the hydraulic disintegration and excavation method is as follows. A hydraulic disintegrator performs primary separation; slurry is sucked through a suction head, combined with an agitator in one draghead [3, 4]. The devices, used for hydraulic fragmentation of underwater face, are divided into two types: facilities for surface and deepwater washing out [5-7]. It is known that the use of jet agitators helps increase the dredger productivity by more than 25% while reducing the excavated soil cost [8-10]. In this regard, substantiation of the rational parameters of jet agitators of dredgers is the topical scientific and engineering problem.

The known previously developed mathematical models make it possible to determine some basic parameters of underwater and sub-bottom wash zones shaped by washing out jet, i.e. range, length, and width [1, 2]. However, the parameters are insufficient to describe the surface of the underwater

face subjecting to the action of a turbulent washing jet [11-13]. In this regard, such models prevent from identification of rational design and technological parameters of the dredger soil suction head with a jet agitator.

The purpose of the work is to develop a mathematical model of the underwater face formation by jet agitators helping construct a contact surface of the turbulent washing jet with the granular mineral being washed out. The development of such a model makes it possible to substantiate rational structural parameters of the dredger soil suction head with a jet agitator.

2 MANUSCRIPT PREPARATION

A comprehensive research method has been applied. The procedure to calculate the rational parameters of hydraulic agitating involved both theoretical study and experiments concerning interaction between turbulent jet streams and underwater face of the loose ground. Standard approaches, criteria of the applied hydrodynamics methods as well as physical and mathematical modelling were applied [14-16]. To confirm the adequacy of the developed

mathematical model, a set of laboratory experiments of jet washing of granular soil was prepared and performed using the developed laboratory facility [17, 18]. The experimental data were processed and analyzed using standard methods of mathematical statistics and planning of experiments [19-21]. Analytical dependencies were derived through approximation of the experimental results using the least square procedure. Industrial full-scale experiments were carried out with the use of operating dredgers under the conditions of minefield mortar sand deposits. Technological and design parameters were measured with the help of standard metric equipment.

2.1 Mathematical modelling

The mathematical model has been constructed in accordance with the previously developed physical model [2, 3]. Thus, this paper considers an inclined water turbulent washing jet, separating particles of grain soil and shaping a bottom face (Figure 1). Operation of the vertical washing jet, as a special case of the inclined jet, is not considered, since the real operation of the dredge in the underwater face is accompanied exclusively by the operation of the inclined washing jet. To develop a model of the contact surface of the inclined washing jet with the underwater face, consider the scheme shown in Figure 1.

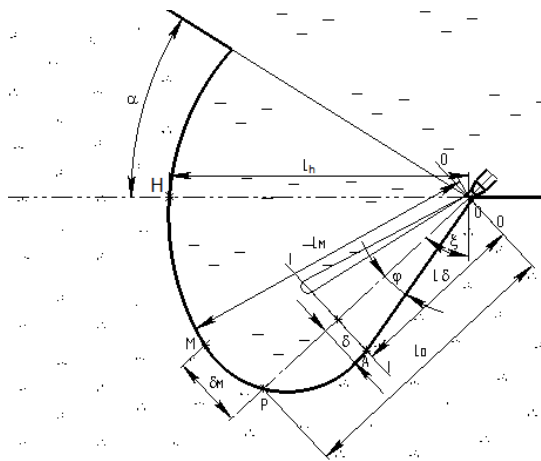

Figure 1: Scheme of an underwater face shaped by a turbulent washing jet.

Assume that a jet of incompressible fluid flows from a nozzle with R radius, into the grained soil formation where particle size is d_{av} . The nozzle is installed at the surface of the reservoir bottom; in this context, the axis of the jet passes through the

intersection of the forming surfaces of the bench and its toe.

The washing zone, formed by such a jet, is an underwater jet washing zone. Introduce some specifications: R is the nozzle radius, m; D_n is the nozzle diameter, m; φ is the angle of unilateral expansion of the outer boundary of the turbulent axisymmetric jet in the main section, deg.; L_δ is the length of the main section of the washing zone, characterizing the distance, singled out along the axis of the jet, between the nozzle and the main section boundary of the underwater jet washing zone, represented by the projection of point A on the axis, m; δ is the maximum half-width of the main jet section, characterizing the distance between point A and the jet axis, m; L_o is the jet range characterizing the distance being singled out along the axis of the jet between the nozzle and the point of the washing zone P spacing maximally from the nozzle, and lying on the jet axis, m; L_m is the furthest point of the washing zone characterizing the distance between the nozzle and the furthest point of the washing zone M , m; δ_m is the distance between M point and the jet axis, m; L_h is the horizontal range, characterizing the distance between the nozzle and the maximum point of the washing area H , and lying within the horizontal plane, m; u_0 is the initial velocity of liquid flow from the nozzle, m/s; $U_p^{\beta\gamma}$ is the analytical value of ground washing velocity at the point of the sloping surface of the underwater jet washing zone, m/s; Q_0 is the fluid flowrate through the nozzle, cross-section 0-0, m^3/s ; and Q_1 is the fluid flowrate through the cross-section 1-1, m^3/s .

Due to the change in the live section of the flow along the length, fluid flow movement in the main section of the underwater jet washing zone is smoothly varied. It has the following characteristics:

- a) centrifugal forces are not taken into consideration;
- b) live flow sections are treated as the planar ones;
- c) projection of the flow live sections on a plane perpendicular to the axis of the jet is a circle; and
- d) vertical flows are not taken into consideration.

The description of the fluid flow in the main section of the underwater jet washing zone is performed using the Euler equation for an ideal (non-viscous) fluid [22-24] generally written as

$$\begin{cases} \frac{du_x}{dt} = \frac{\partial u_x}{\partial t} + u_x \frac{\partial u_x}{\partial x} + u_y \frac{\partial u_x}{\partial y} + u_z \frac{\partial u_x}{\partial z}; \\ \frac{du_y}{dt} = \frac{\partial u_y}{\partial t} + u_x \frac{\partial u_y}{\partial x} + u_y \frac{\partial u_y}{\partial y} + u_z \frac{\partial u_y}{\partial z}; \\ \frac{du_z}{dt} = \frac{\partial u_z}{\partial t} + u_x \frac{\partial u_z}{\partial x} + u_y \frac{\partial u_z}{\partial y} + u_z \frac{\partial u_z}{\partial z}. \end{cases} \quad (1)$$

Consider the flow movement in the main section of the jet underwater washing zone (Figure 1) along the O-X axis when it is expanding towards O-Y and O-Z axes. The flow rate in sections 0 and 1 is constant, i.e. $Q = const$. Hence,

$$Q_0 = Q_1 = s_0 u_0 = s_1 u_1.$$

Then the flow velocity will be

$$u_0 = \frac{Q_0}{s_0} = \frac{Q_0}{\pi R^2} \quad u_1 = \frac{Q_1}{s_1} = \frac{Q_0}{\pi R_x^2},$$

where R_x is the radius of the main section of the axisymmetric washing jet in the i^{th} section.

Relying upon the theory of flowing of flooded jets [1,2,23] for the main section, the change in the parameters of the circular section along the coordinate x will be represented as

$$R_x = xtg\varphi. \quad (2)$$

According to [25], $\varphi = 12^\circ 30'$. The tangent of the expansion angle is commonly referred to as the expansion coefficient c ; then, $c = tg\varphi = 0.22$.

Transversely (i.e. along y co-coordinate), the dependence of the flow velocity upon the longitudinal velocity (i.e. along x coordinate) will be

$$u_y = \frac{dR_x}{dt} = tg\varphi \frac{dx}{dt} = tg\varphi u_x = c \cdot u_x$$

Due to the change in a cross-sectional area, the flow in the main section of the axisymmetric washing jet is uneven. Since the time-controlled velocity changes result from uniform flow expansion, the partial time velocity derivatives are very small compared with the other terms of the equation; so

$$\frac{\partial u_x}{\partial t} = 0 \quad \frac{\partial u_y}{\partial t} = 0 \quad \frac{\partial u_z}{\partial t} = 0$$

To solve simple problems, it is enough to consider the flow as a one-dimensional value and determine the maximum velocity and acceleration values. Then, the system of equations (1), taking into consideration the described dependencies of the flow

velocity in the transverse and vertical directions, can be written in the form

$$\frac{du_x}{dt} = u_x \frac{\partial u_x}{\partial x} + cu_x \frac{\partial u_x}{\partial y} + cu_x \frac{\partial u_x}{\partial z}$$

In view of the assumptions about the insignificance of the curvature of flow live sections, equating the flow velocity at any point to its mean value, bringing the parameters of the flow live section to the axis O-X, as well as solving a flat problem, the system of equations (1) is reduced to the form

$$\frac{du_x}{dt} = u_x \frac{\partial u_x}{\partial x} \quad (3)$$

In the main section of the axisymmetric washing jet, the change of parameters of the circular section along x coordinate is described by expression (2). Hence, we obtain the flow velocity as the ratio

$$u_x = \frac{Q_0}{\pi(c \cdot x)^2} \quad (4)$$

Involving $Q_0 = \pi u_0 R^2$, private derivative $\frac{\partial u_x}{\partial x}$ will take the following form:

$$\frac{\partial u_x}{\partial x} = -\frac{u_0 R^2}{c^2 x^3} \quad (5)$$

Then, transforming (3) and taking into consideration the expression for flow velocity (4) as well as the type of partial derivative (5), we write flow acceleration in the main section of the axisymmetric washing jet as

$$\frac{du_{xp}}{dt} = -\frac{u_0^2 R^4}{c^4 x^5} \quad (6)$$

The main section of the jet is characterized by a regular decrease in velocity values in accordance with the increase in the cross-sectional area of the flow. The flow in the section under consideration is characterized by negative, acceleration values, approaching zero. Proceeding from the equality of productivity in sections 0 and 1 (Figure 1), we obtain

$$Q_0 = Q_1 = u_0 \pi R^2 = u_x \pi c^2 x^2$$

It is known that the velocity at the contact surface of the jet with the grained soil in section 1-1 is equal to the value of washing velocity $u_x = U_p^{\beta\gamma}$.

According to the earlier research by the author

(see [1,2]), upper indices β and γ characterize the value of the slope angles of the surface formations of the jet-washing underwater zone. Thus, the equation to determine the main section length of the washing zone will be

$$L_{\delta} = \frac{R}{c} \sqrt{\frac{u_0}{U_p^{\beta\gamma}}} \quad (7)$$

The correspondence of the mathematical model to the actual physical picture, taking place in the underwater face of the turbulent jet, becomes possible if empirical coefficient k is introduced into the dependence (7)

$$L_{\delta} = \frac{R}{kc} \sqrt{\frac{U_0}{U_p^{\beta\gamma}}} \quad (8)$$

Analysis of the empirical curves, obtained as a result of earlier experimental studies using the developed laboratory facility [1, 2], helps formulate a type of dependence of the coefficient k upon the initial velocity of the liquid flow from the nozzle u_0 and the angle of inclination of the jet axis

$$k = \left(\frac{\alpha}{\xi}\right)^m (a - bu_0) \quad (9)$$

where α is the natural slope angle of the underwater bench when mining by a dredger. The normative value of the angle for water-saturated medium-grained sand is $\alpha = 32^\circ$ [5, 10]; ξ is the inclination angle of the washing jet axis, deferred from the vertical one, degrees; and a, b, m are the empirical coefficients.

Consideration of a turbulent inclined water jet, forming sections of the turning and return flow (Figure 1), allows us to argue about the complexity of running processes to perform mathematical modelling with the theoretical model construction. Calculation of forces of the impact of jet flow on the grained soil, leading to relevant perturbations in the latter, is a very complex problem of fluid dynamics of jet streams. Therefore, the paper aim is to develop a mathematical model helping us set the values of a sufficient number of geometric parameters to design the contact surface of the washing jet with the grained soil based on empirical models.

Resulting from estimating processing of experimental data, empirical dependencies to determine the geometric parameters required to construct the contact surface of the washing jet with the grained soil were obtained [1, 2]:

- axial jet range

$$L_o = c_{L_o} \frac{\text{Re}v_n}{U_p^{\beta_{90}\gamma_0}} - d_{L_o} \Delta_U d^{ls} + e_{L_o} d^{ls} ;$$

- the furthest point of the washing area

$$L_m = c_{L_m} \frac{\text{Re}v_n}{U_p^{\beta_{90}\gamma_0}} - d_{L_m} \Delta_U d^{ls} + e_{L_m} d^{ls} ;$$

- distance between M point and the jet axis

$$\delta_m = c_{\delta_m} \frac{\text{Re}v_n}{U_p^{\beta_{90}\gamma_0}} - d_{\delta_m} \Delta_U d^{ls} + e_{\delta_m} d^{ls} ;$$

- horizontal range

$$L_h = c_{L_h} \frac{\text{Re}v_n}{U_p^{\beta_{90}\gamma_0}} - d_{L_h} \Delta_U d^{ls} + e_{L_h} d^{ls} ;$$

where $c_{L_o}, d_{L_o}, e_{L_o}, c_{L_m}, d_{L_m}, e_{L_m}, c_{\delta_m}, d_{\delta_m}, e_{\delta_m}, c_{L_h}, d_{L_h}, e_{L_h}$ are the empirical coefficients; Δ_U is the notional velocity; and d^{ls} is the near-mesh grain of the soil assumed to be 0.00016 m.

2.2 Laboratory Experiments

Numerical values of the empirical coefficients were obtained as a result of experimental data processing during the study of soil washing by an inclined turbulent jet in the underwater face. The procedure was studied using laboratory conditions when a turbulent water jet was applied to the sand of medium grain size $d_{av} = 0.265$ mm with slope angles $\xi = 15, 30, 45, 60, 75,$ and 90 degrees, and the diameters of the washing jet nozzle being $D_n = 1.25; 2.0; 2.8;$ and 4.0 mm.

To provide visual control and the possibility to perform appropriate measurements of the washing zone formation for underwater surface using a water jet in a loose soil, a laboratory facility was designed (see Figure 2).

Following problems have been solved with the help of the laboratory facility:

- formation process of the underwater surface washing zone has been studied using a single water jet action on a loose ground in terms of 0-90° angles of its axis inclination from the vertical;
- behavioural processes of the loose ground, laid with the appropriate angle of the natural slope, has been analyzed as well as the solids suspended by the jet stream during its underwater washing by the water jet;

- rational operating modes of a water jet, have been defined while shaping the underwater surface mine working to determine rational design parameters of a soil suction head with a jet agitator.

Values of empirical coefficients $a=1.2$, $b=0.503$, and $m=0.18$ were obtained through experiments made for the underwater face shaped under the action of a washing turbulent jet with $\xi = 15^\circ, 30^\circ, 45^\circ, 60^\circ, 75^\circ$, and 90° inclination angles; on an average, 50 experiments have been carried out for each angle.



Figure 2: General view of the laboratory facility to study soil underwater washing processes by a water jet.

2.3 The Experimental Data Processing and Analyzing

Values of the empirical coefficients were obtained as a result of data processing using the method of least squares based on the Mathcad program as well as statistical data processing in the Microsoft Office Excel program. Statistical analysis of the experimental data showed standard deviation of individual measurements from the calculated values; for example, in the context of the main section length of washing jet it was 18.5 %, and 13.2 % in the context of jet range. Confidence interval for the mathematical expectation with 90% certainty was 4.5 % and 3.2 % of the analytical values, respectively. Confidence interval for the mathematical expectation of coefficient, calculated by (9), was 5.6% from the calculated values with 90% confidence.

Figure 3 represents graphically the empirical dependence and experimental values, for example, it concerns length of the washing jet main section from the initial velocity of the liquid flow from the nozzle. Analysis of the graphs has assured us that increase in the initial velocity of the flow results in the increase of the studied parameters; moreover, they have a linear function within the specified velocity range.

The proposed model, determining the length of washing zone of the main section, makes it possible to set the value of the maximum half-width of the jet main section in accordance with the theoretical dependence $\delta=cL_\delta=0.22L_\delta$.

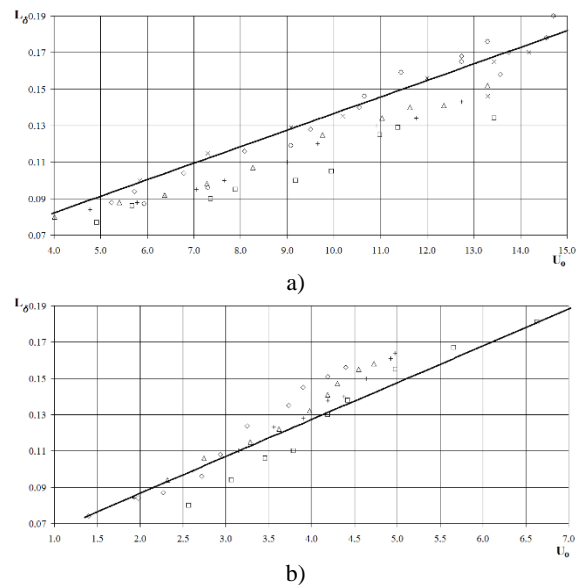

Figure 3: Dependence of jet range L_δ on the initial flow velocity u_0 depending upon a nozzle diameter, mm: a) $D_n = 2.0$; b) $D_n = 4.0$.

Theoretical and empirical mathematical models obtained by the author are used in the design and modernization of dredging equipment with a jet agitator. In this case, it is important to take into consideration the rational balance between the geometric parameters of the underwater face, shaped by the turbulent water jet, and such parameters of the jet agitator as the radius of the washing nozzle; their number; direction; and the initial velocity of the fluid flow from the nozzle. Correct calculation of the rational parameters of jet agitators is an important factor in the process of soil washing velocity identification where slope angle of the washing zone surface is taken into consideration [1, 2].

Transformation of dependence (8) helps derive the analytical expression to determine the washing nozzle diameter

$$D_{\phi} = 2L_{\delta}kc\sqrt{\frac{U^{\beta\gamma}}{P}} \cdot U_0$$

2.4 Industrial Full-Scale Experiments and Implementations

The developed mathematical model to calculate jet agitators was tested while designing such ejector dredgers as *3HC 630-90*, and *3HC 300-120*, and updating dredge suction devices of *CCБ 500/440*, *M3-16Э*, *M3-8*, *M3-11*, *Pechora*, and *ГППП-11* dredgers. The detailed information about the projects by the author can be found on the site htmp.com.ua.



a)



b)

Figure 4: Soil suction head of the jet pump dredger *3HC 300-120* with a jet disintegration system: a) its general view; b) jet pump.

The ejector dredgers *3HC 630-90* and *3HC 300-120* are unique devices designed for extracting and dredging construction works under the difficult mining and geological conditions; if coarse gravel occurs in the ground; if off-shore operations are required; or operations take place at shallow depths [9].

Experimental tests of ejector dredgers *3HC 630-90* and *3HC 300-120*, equipped with suction heads, jet pumps, and agitators (see Figure 4), have shown their advantages and disadvantages. Industrial tests confirmed sufficient convergence of the analytical and experimental data, indicating relevance of the developed mathematical model. The mentioned ejector dredgers are widely used for dredging and mining operations in rivers and water-flooded quarries (Figure 5) [2, 9].



a)



b)

Figure 5: Jet pump dredgers: a) *3HC 630-90* ejector dredger at a mining site in Liberia; b) *3HC 300-120* ejector dredger in the flooded quarry of Ukraine.

Use of the developed system for soil preparation and hydro-transportation by turbulent jets under the specified conditions has helped:

- maintain sand mining productivity at the same level;
- reduce the cost by 15%;
- reduce current repair and maintenance of the equipment by 28%;
- develop soil with up to 200 coarseness mm; and
- reduce sand mining cost by 12%.

The obtained results offer us the possibility to recommend ejector dredger *3HC 630-90* for production. At present, *3HC 630-90* dredgers are applied successfully to develop nonmetallic river gravel deposits in Ukraine and a diamond deposit in Liberia (Figure 5) [2, 9].

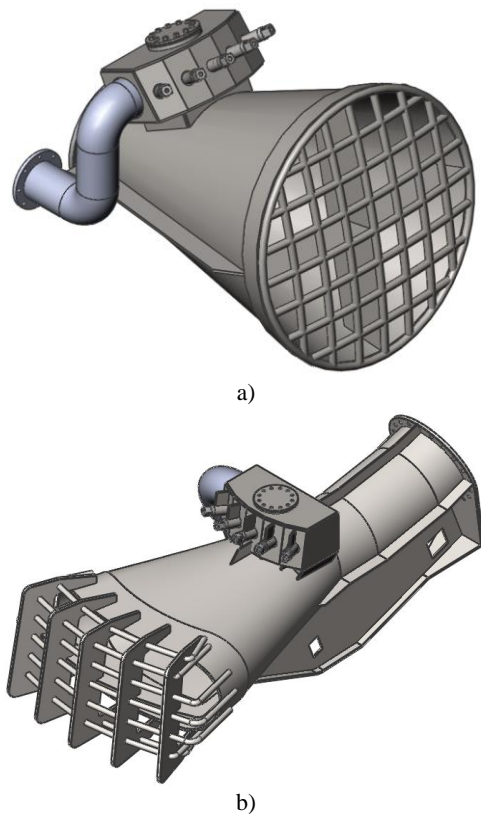

Figure 6: Modernized suction heads of the dredgers: a) *Pechora*, b) *ГППП-11*.

The developed mathematical model, calculating jet agitators, has also been used by the author to modernize a suction head of operating dredgers. Off-shore hopper dredger *Pechora* and river specialized sand loader *ГППП-11* are the examples [10]. Suction heads of the mining vessels have been upgraded by

the jet agitation systems. Solid models of the upgraded suction heads with the jet agitation systems are shown in Figure 6. The detailed information about the projects can be found on the site http.com.ua.

Use of jet technologies to intensify soil washing in the underwater face has made it possible to modernize the dredge suction heads with minimal interference in the design of the facilities. It is also important that such modernization needs neither specialized equipment nor personnel qualification. Moreover, it can be performed by the mining company in accordance with the current relevant standards and regulations.

Pechora and *ГППП-11* updating has increased significantly the performance capability and efficiency of mining operations; quantitative factors are being processed and improved.

3 CONCLUSION

The result of mathematical modelling of the underwater surface face formation process by jet agitator was the obtaining of an analytical dependence to determine the diameter of the washing nozzle as a function being directly proportional to the length of the main section of the jet, the square root of *soil washing velocity-initial flow rate* ratio, and the coefficient, which is inversely proportional to the washing jet axis slope raised to the 0.5th power. In addition, theoretical and empirical dependencies to define geometric parameters of the surface underwater face were obtained as a result of evaluating the effect of nozzle diameter and inclination angle of the washing jet axis on the formation of differently inclined surfaces of the turbulent water jet within the underwater face.

The developed mathematical model, calculating jet agitators, has been tested and successfully applied while designing *3HC 630-90* and *3HC 300-120* ejector dredgers as well as upgrading dredging equipment of *CCB 500/440*, *M3-16Э*, *M3-8*, *Pechora*, and *M3-11* dredgers.

REFERENCES

- [1] A. Bondarenko, "Mathematical modeling of soil dredger absorption processes in the underwater bottomhole," *Metallurgical and Mining Industry*, vol. 3, pp. 79-81, 2012.
- [2] A. Bondarenko and Ye. Zapara, "Laws of determination of fine materials suction limits in submarine suction dredge face," *Naukovi Visnyk*

- Natsionalnoho Hirnychoho Universytetu, vol. 4, pp. 59-64, 2012.
- [3] O. Medvedeva, "Development and exploitation of storages of enrichment process wastes as anthropogenic deposits," Theoretical and practical solutions of mineral resources mining, Taylor & Francis Group, London, 2015.
- [4] O. Medvedieva, S. Kyrychko, N. Nykyforov, and N. Koval, "Substantiation of the boundary of the tailings storage core during the storing of the cleaning rejects by hydraulic method," E3S Web of Conferences, vol. 109, International Conference Essays of Mining Science and Practice, Dnipro, Ukraine, June 25-27, 2019.
- [5] SOU-N MPP 73.020-078-3:2013, "Normy tehnolohichnogo proektuvannia hynychovydobuvnykh pidpriemstv iz vidkrytym sposobom rozrobky rodovysshch korysnykh kopalyn," DPI Kryvbasproekt, Kryvyi Rih, 2013.
- [6] E. Semenenko, N. Nykyforova, and L. Tatarko, "The method of hydraulic gradient and critical velocity calculation for hydrotransportation of particles with substantially different densities," in 15th International Freight Pipeline Society Symposium, June, 24-27, Prague, pp. 248-256, 2014.
- [7] Y. Semenenko, S. Kril, N. Nykyforova, L. Tatarko, and O. Medvedieva, "Calculation of pressure loss and critical velocity for slurry flows with additive agents in vertical polyethylene pipelines," E3S Web of Conferences, vol. 109, International Conference Essays of Mining Science and Practice, Dnipro, Ukraine, June 25-27, 2019.
- [8] A. Dryzhenko, S. Moldabayev, A. Shustov, A. Adamchuk, and N. Sarybayev, "Open pit mining technology of steeply dipping mineral occurrences by steeply inclined sublayers," in 17th International Multidisciplinary Scientific GeoConference SGEM 2017, pp. 599-605, 2017.
- [9] A. Dryzhenko, A. Shustov, and S. Moldabayev, "Justification of parameters of building inclined trenches using belt conveyors," in 17th International Multidisciplinary Scientific GeoConference SGEM 2017, pp. 471-478, 2017.
- [10] T. Al-Azab, F.M. Al-Ghathian, J.S. Haddad, et al., "Experimental Study of Drying Ratio and Humidity of Silica Sand Materials," J. Engineering, Thermophys, p. 550, 2019.
- [11] Ye. Semenenko, N. Nykyforova, and L. Tatarko, "The features of calculations of hydrotransport plans of geotechnological systems," Theoretical and practical solutions of mineral resources mining, Taylor & Francis Group, London, 2015.
- [12] O. Belov, O. Shustov, A. Adamchuk, and O. Hladun, "Complex Processing of Brown Coal in Ukraine: History, Experience, Practice, Prospects," Solid State Phenomena, vol. 277, pp. 251-268, 2018.
- [13] O. Denyshchenko, A. Shyrin, V. Rastsvietaiev, and O. Cherniaiev, "Forming the structure of automated system to control ground heavy-type ropeways," Natsional'nyi Hirnychiy Universytet. Naukovyi Visnyk, no. 4, pp. 79-85, 2018.
- [14] O. Anisimov, V. Symonenko, O. Cherniaiev, and O. Shustov, "Formation of safety conditions for development of deposits by open mining," E3S Web of Conferences forthcoming.USME 2018, 2018.
- [15] V. Symonenko, J.S. Haddad, O. Cherniaiev, et al., "Substantiating Systems of Open-Pit Mining Equipment in the Context of Specific Cost," J. Inst. Eng. India Ser. D, p. 301, 2019.
- [16] S. Moldabayev, Z. Sultanbekova, A. Adamchuk, and N. Sarybayev, "Method Of Optimizing Cyclic And Continuous Technology Complexes Location During Finalization Of Mining Deep Ore Open Pit Mines," in 19th SGEM International Multidisciplinary Scientific GeoConference EXPO Proceedings, Science and Technologies in Geology, Exploration And Mining, vol. 19, pp.407-414, 2019.
- [17] O. Shustov, O. Bielov, T. Perkova, and A. Adamchuk, "Substantiation of the ways to use lignite concerning the integrated development of lignite deposits of Ukraine," Naukovyi Visnyk Natsionalnoho Hirnychoho Universytetu, no. 3, pp. 5-18., 2018.
- [18] V. Nadutyi, J. Haddad, V. Sukhariev, and A. Loginova, "The results of experimental studies of influence of variable parameters on the performance indicators of shock-centrifugal disintegrator," Naukovyi Visnyk Natsionalnoho Hirnychoho Universytetu 169, no. 1, pp.42-47, 2019.
- [19] V. Nadutyi, O. Tytov, and I. Cheberiachko, "Hereditary model of loose mined rock layer deformation in disintegrators," E3S Web of Conferences, vol. 60, 00033, Ukrainian School of Mining Engineering, 2018.
- [20] O. Tytov, J. Haddad, and V. Sukhariev, "Modelling of mined rock thin layer disintegration taking into consideration its properties changing during compaction," in E3S Web of Conferences, vol. 109, International Conferences Essays of Mining Science and Practice, 2019.
- [21] O. Chernyaev, "Systematization of the hard rock non-metallic mineral deposits for improvement of their mining technologies," Naukovyi Visnyk Natsionalnoho Hirnychoho Universytetu, no. 5, pp. 11-17, 2017.
- [22] J. Bedrossian and V. Vicol, "The Mathematical Analysis of the Incompressible Euler and Navier-Stokes Equations: An Introduction," American Mathematical Society, 218 p., 2022.
- [23] Ch. Wang, Zh. Chang, W. Chao, and Yu. Zhengand, "Local Well-Posedness and Break-Down Criterion of the Incompressible Euler Equations with Free Boundary," American Mathematical Society, 119 p., 2021.
- [24] D. Stipp, "A Most Elegant Equation: Euler's Formula and the Beauty of Mathematics," Basic Books, 240 p., 2017.
- [25] G. Abramovich, "The Theory of Turbulent Jets," Edited by Leon Schindel. The MIT Press, 684 p., 2003.