

Res Electricae Magdeburgenses
Magdeburger Forum zur Elektrotechnik

Biljana Hadzi-Kostova

Protection Concepts in Distribution Networks
with Decentralised Energy Resources

Otto-von-Guericke-Universität Magdeburg

Magdeburg 2005

Protection Concepts in Distribution Networks
with Decentralised Energy Resources

Dissertation

zur Erlangung des akademischen Grades

**Doktoringenieurin
(Dr.-Ing.)**

von Biljana Hadzi-Kostova
geb. am 15.08.1977 in Skopje

genehmigt durch die Fakultät Elektrotechnik und Informationstechnik
der Otto-von-Guericke-Universität Magdeburg

Gutachter: Prof. Dr.-Ing. habil. Zbigniew Styczynski
Prof. i. R. Dr. Arun G. Phadke
Dr.-Ing. Rainer Krebs

Promotionskolloquium am 25. Oktober 2005

Res Electricae Magdeburgenses

Magdeburger Forum zur Elektrotechnik, Jg. 3, Band 11, 2005

IMPRESSUM:

Herausgeber:

Prof. Dr. rer. nat. Jürgen Nitsch,
Institut für Grundlagen der Elektrotechnik und Elektromagnetische Verträglichkeit

Prof. Dr.-Ing. Zbigniew Antoni Styczynski,
Institut für Elektrische Energiesysteme

beide: Otto-von-Guericke-Universität Magdeburg, Postfach 4120, 39016
Magdeburg

V. i. S. d. P.:

Biljana Hadzi-Kostova
Otto-von-Guericke-Universität Magdeburg, Postfach 4120, 39016 Magdeburg

1. Auflage, Magdeburg, Otto-von-Guericke-Universität, 2005

Zugl.: Magdeburg, Univ., Diss., 2005

Auflage: 200

Redaktionsschluss: 2005

ISSN 1612-2526

ISBN 3-929757-84-2

© Copyright 2005 Biljana Hadzi-Kostova

Bezug über die Herausgeber

Druck: Otto-von-Guericke-Universität Magdeburg,
Abteilung Allgemeine Angelegenheiten, Postfach 4120, 39016 Magdeburg

Preface

This dissertation contains my research work done as an assistant at the Institute for Electrical Power Systems at the Otto–von–Guericke-University Magdeburg, Germany.

I would like to express my gratitude to my supervisor Prof. Dr. Z. Styczynski for giving me the chance to work at his chair on this very interesting engineering area.

I would like to thank Prof. i. R. Dr. A. Phadke, Virginia Technical University, USA for being the external examiner of my dissertation and for his interest in my work. I would also like to thank Dr.-Ing. R. Krebs, Power Technologies Siemens, Erlangen, Germany for the very close cooperation and the exchange of ideas as well as for being one of my examiners.

I thank my colleagues from the University of Magdeburg and the University of Wroclaw, Poland, as well as from Siemens AG, for their co-work and friendship.

Finally, I thank my family and friends for their support and encouragement during the writing of this work.

Biljana Hadzi-Kostova

Contents

1.	Introduction. Goal, thesis and work structure	1
1.1	Introduction	1
1.2	Goals, thesis and work structure.....	2
2.	Einleitung. Ziele, These und Struktur der Arbeit.....	5
2.1	Einleitung.....	5
2.2	Ziele, These und Struktur der Arbeit	6
3.	Digital protection in distribution networks	9
3.1	General information about protection systems	9
3.2	General information about numerical protection.....	10
3.3	Functional principle of over-current protection	12
3.4	Functional principle of distance protection	14
3.5	Functional principle of differential protection	16
4.	The implementation of DER in the network and its influence on digital protection	18
4.1	Introduction. General information of the technologies of DER.....	18
4.2	Connection of DER to the network	19
4.3	Modelling of DER for protection coordination tasks	33
4.3.1	Fuel cells modelling.....	33
4.3.2	Photovoltaic modelling.....	34
4.3.3	Electrical energy storage devices modelling	35
4.3.4	Wind power plants modelling	36
5.	The influence of a high amount of harmonics on different types of protection devices	39
5.1	Introduction	39
5.2	Modelling distance protection in MATLAB.....	41
5.2.1	General information about the investigation	41
5.2.2	Steady-state algorithms.....	43
5.2.3	Algorithms based on DEFO	45
5.2.4	Algorithms based on DESO.....	48
5.2.5	Algorithms using filter approach	49
5.2.6	Algorithms using parametric estimation	53
5.2.7	Algorithms using HANN.....	55
5.3	Practical analyses of digital protection devices	61
5.4	Modelling of differential protection devices	63
6.	Protection systems in networks with DER.....	65
6.1	Introduction. Impacts of power supply systems and challenges of protection systems	65
6.2	Investigations in test networks.....	68
6.2.1	Test networks.....	68
6.2.2	Network scenarios and discussion.....	70
6.2.3	Analysis of the simulation results	80

6.3	Implementation of the possibility of recognising the fault current direction	86
6.4	New approaches in protection systems with DER.....	88
6.4.1	Introduction	88
6.4.2	The standards IEC 61850 and IEC 61970	91
6.4.3	Communication in distribution networks with DER	103
6.5	New concept of network protection based on additional signal injection.....	110
7.	E-learning – The new teaching method.....	114
7.1	Introduction	114
7.2	E-learning system - Virtual protection technique	115
7.2.1	Structure of the e-learning system	115
7.2.2	Chapter contents and Realisation	115
7.3	Results of implementation of e-learning system	121
8.	Conclusion	123
9.	Zusammenfassung	125
10.	Literature.....	127

List of Acronyms

DER	decentralised energy resources
IED	intelligent electronic devices
I/O	input-output
HMI	human-machine interface
RAM	random access memory
ROM	read only memory
PROM	programmable ROM
CT	current transformer
A/D	analogue/digital
DFT	discrete Fourier transformation
VT	voltage transformer
LV	low voltage
MV	medium voltage
LOM	loss of mains
LOS	loss of grid
PCC	point of common coupling
FC	fuel cell
CHP	combined heat and power
PEM	polymer electrolyte membrane
PV	photovoltaic
ESD	energy storage device
DFIG	double feed induction generator
DEFO	differential equation of first order
DESO	differential equation of second order
FFT	fast Fourier transformation
HANN	harmonic activated neuronal networks
LSQ	least square
BP	back propagation
RTDS	real time digital simulator
PD	protection device
RTU	remote terminal unit
IT	information technology
LN	logical nodes
SAS	substation automation system
EMS	energy management system
SCADA	supervisory control and data acquisition
IF	interface
PMU	phasor measurement unit
EES	electrical energy system

1. Introduction. Goal, thesis and work structure

1.1 Introduction

The digital protection technique of today joins knowledge not only from its own field, but also from the fields of digital signal processing, power quality, theory of variability and estimation, fuzzy logic and artificial intelligence. The basic principles of the function of the modern numerical protection technique are still the same as mechanical or analogue electrical protection devices, although the methods of the data processing and evaluation are changing with the development of the implemented software. The main function of the power system protection is keeping the system in a functional unity according to the secure power system operation principle e.g. (n-1) principle. The protection technique is still confronted with the demands of selectivity, effectivity, sensitivity, reliability, and it must be fast and inexpensive. The costs of the protection systems depend on the type of protection device used. The lowest costs have devices that use the over-current principle. For the connection to the protecting element they need only current transformers. The implementation of the time-gradation and direction principle to this type of protection improves the selectivity on the cost of the price of the devices. A further improvement is the criteria of distance-to-the-fault calculation. This protection system requires use also of voltage transformers. The best selectivity offers differential protection, but the costs rise because of the need for a communication link on both sides and additional necessary backup functions.

Normally, in power system, a functionally suitable protection system is joined to each electrical element (passive or active) e.g. power line → distance protection system, transformer → differential protection system, small electrical motor on the medium voltage level → over-current protection system. To fulfil the requirements of selectivity, the protection system realised as primary and back-up protection joins different protection system types in a logical structure e.g. differential, over-current, distance.

As a result of the conclusions set within the Kyoto Protocol, a worldwide initiatives concerning environmental pollution and world energy dependence on limited energy resources are being carried out. In this chain of initiatives the distribution networks have witnessed relatively fast changes in their structure. Beginning with the liberalisation of the energy markets, and especially due to the implementation of decentralised and renewable energy resources (DER) into the network, the network structure is changing from centralised to decentralised. In a network with high penetration of DER, the direction of power flow, which was clearly defined before, changes according to the ratio of energy offered from DER and the power system on the higher voltage level and the energy demand from the network costumers. However the protection systems installed in the power system are not set to manage these variable changes of direction of power flow. Because of the lack of "powerful" generators that can create a strong network, such a network characterises by a very low short circuit power, which is definitely going to affect the protection system. The protection devices implemented in the network are about to be set to match these changes. Consequently new protection concepts for each system are necessary. These problems are discussed in this dissertation.

1.2 Goals, thesis and work structure

The goals of this dissertation are:

- investigation of new situations in power systems with high penetration of DER;
- analysis of present protection algorithms taking into account the high penetration of DER;
- investigation of protection concepts in networks with high penetration of DER.

For the realisation of these goals some exemplary networks are used to discuss the occurring problems and the solving methods, they don't present a generalisation of the problems of protection schemes in networks with high penetration of DER, but play only an illustrative role.

In the exemplary networks the DER are connected to the network via inverters.

The thesis of this work is that it is possible to operate the power system with high penetration of DER (theoretically) with actual protection schemes, when some special effects concerning the protection scheme and the connection of DER to the network are taken into account.

This work will be presented as follows.

Chapter 3 presents the basic definitions concerning digital protection. This chapter presents the structure of the protection systems and the functional principle of different types of protection systems used in distribution systems.

Chapter 4 analyses the basic problems concerning protection concepts in medium voltage networks with high penetration of DER. This chapter presents the possibilities of installation of DER in medium voltage networks. The modelling of DER for protection coordination purposes is also given.

Chapter 5 presents an investigation of different protection algorithms implemented in protection relays in networks with high penetration of DER. The focus of the investigations is the influence of the high amount of harmonics in such networks on the protection systems. The influence of high amount of harmonics on different types of protection relays and different algorithms is going to be presented. The investigations have been made theoretically, as simulations, as well as practically, in the network protection laboratory at the Otto-von-Guericke-University.

In Chapter 6, the protection concepts before and after the implementation of DER are analysed and compared on example of two distribution networks. The problems of lack of protection in islanded operation are shown, as well as possible idea solutions for the network protection.

Chapter 6 presents also two protection concepts for power system protection in networks with high penetration of DER. These concepts are mostly based on the new standard for substation automation system - IEC 61850. The second concept presents an idea of protecting distribution networks using an additional signal injection.

The investigations are completed by an e-learning course, in the area of digital network protection, presented in Chapter 7. This e-learning course has been implemented as an addition to the conventional study program at the Otto-von-Guericke-University.

2. Einleitung. Ziele, These und Struktur der Arbeit

2.1 Einleitung

In der modernen Netzschutztechnik wird Fachwissen verschiedenster Wissensfelder wie digitale Signalverarbeitung, Spannungsqualität, mathematisch basierte Theorien über Variabilität und Einschätzung, Fuzzy Logik und künstlicher Intelligenz verwendet. Die grundsätzlichen Funktionsprinzipien moderner Schutzsysteme sind immer noch die gleichen geblieben wie bei den mechanischen oder analog-elektrischen Schutzrelais, obwohl die Methoden der Signalverarbeitung sich stark geändert haben. Die Hauptfunktion der Schutzsysteme ist gleichgeblieben – Haltung des elektroenergetisches Systems in einer Einheit unter Berücksichtigung des sicheren Betriebsprinzip, z.B. des (n-1) Prinzips. Zusätzlich werden den Schutzsystemen folgende Anforderungen gestellt: Selektivität, Effizienz, Sensibilität, Zuverlässigkeit, Schnelligkeit und Kosten optimiert. Die Kosten der Netzschutzsysteme hängen von der Art des benutzen Schutzgerätes ab. Die Netzschutzsysteme, die das Überstromprinzip nutzen, sind am Preis günstigsten. Die Integration der Kriterien von Zeit- bzw. Stromstaffelung und Richtung verbessern die Selektivität des Netzschutzsystems, erhöhen aber die Kosten. Eine weitere Verbesserung der Selektivität wird durch das Impedanzermittlungsprinzip erreicht. Diese Distanzschutzsysteme benötigen aber zusätzliche Spannungswandler. Die beste Selektivität wird mit Differenzialschutzsystem erreicht, wobei die Kosten des Systems wegen der zusätzlichen Kommunikationsleitungen steigen.

In der Energietechnik ist üblicherweise jedem elektronischen, aktiven, oder passiven Element ein passendes Hauptschutzsystem zugeordnet. Z. B. Leitung → Distanzschutzsystem, Transformator → Differentialschutzsystem, kleiner el. Motor an Mittelspannungsebene → Überstromzeitschutzsystem. Um die Anforderungen bezüglich Selektivität zu erfüllen, im Sinne von Primär- und Sekundärschutz, wird das Netzschutzkonzept mit logischer Verbindung mehrerer Schutzsysteme, z.B. Differential, Überstrom, Distanz realisiert.

Als Folge des Kioto-Protokolls wurde eine weltweite Initiative zum schonenden Umgang mit den Naturenergiequellen ins Leben gerufen. Diese Initiative löste eine Kettenreaktion aus, welche unter anderen Veränderungen in den Verteilungsnetzen zur Folge hat. Ausgelöst durch die Liberalisierung der Energiemärkte und mit steigender Anzahl dezentraler und erneuerbarer Energieerzeuger am Netz, ist sich die Netzstruktur in eine dezentrale am Umwandeln. In Netzen mit hohem Anteil an dezentralen Energieerzeugern (DER) kann sich die Richtung des Lastflusses in der Abhängigkeit des Quotienten der Energieerzeugung (aus DER und dem überlagerten Netz) und des Energieverbrauches ändern. Die bestehenden Netzschutzsysteme sind hierfür nicht parametrisiert und können die schnellen Änderungen der Lastflussrichtung nicht bewältigen. Diese Netze charakterisieren sich durch kleine Kurzschlussleistung, die die Funktionalität der Netzschutzsysteme gefährden kann. Die eingesetzten Netzschutzsysteme mit neuen Konzepten werden diese Herausforderungen erfüllen. Diese Probleme werden in dieser Dissertation untersucht.

2.2 Ziele, These und Struktur der Arbeit

Die Ziele dieser Dissertation sind:

- Untersuchung der neuen Situationen in Energiesystemen mit hohem DER-Anteil;
- Analyse unterschiedlicher Schutzalgorithmen unter Berücksichtigung hohen DER-Anteil;
- Untersuchung der Netzschutzkonzepte in Energiesystemen mit hohem DER-Anteil.

Zur Realisation dieser Ziele werden einige Beispielnetze benutzt, um die Probleme und die möglichen Lösungen zu präsentieren. In den Beispielnetzen sind die DER über einen Umrichter ans Netz gebunden. Die untersuchten Lösungen präsentieren keine Generalisation der Probleme verbunden mit Netzschutzkonzepten in Netzen mit hohem DER Anteil, sondern haben eine illustrative Rolle.

Die These ist: Mit dem bestehenden Netzschutzkonzepten ist es möglich das Energiesystem mit hohem Anteil von DER (theoretisch) zu betreiben, aber einige spezielle Effekte im Bezug auf die Netzschutzkonzepte sowie die Art der Anbindung von DER ans Netz, müssen unter Berücksichtigung genommen werden.

Die Arbeit ist wie folgt gegliedert.

Kapitel 3 präsentiert die Grundlagen der Netzschutztechnik. Die Struktur der unterschiedlichen Netzschutzsysteme in der Mittelspannungsebene, sowie ihrer Funktionalitätsprinzipien werden erläutert.

Kapitel 4 analysiert die Grundprobleme der Netzschutzsysteme in Netze mit hohem DER Anteil. Dieses Kapitel präsentiert die Möglichkeiten der Anbindung von DER an das Mittelspannungsnetz. Die Modellierung von DER für Netzschutzkoordination, ist ebenfalls untersucht.

Kapitel 5 zeigt die Untersuchungen unterschiedlicher Netzschutzalgorithmen in Netzen mit hohem Anteil von DER. Der Fokus der Untersuchungen ist auf einem hohen Anteil von Harmonischen gelegt. Die Beeinflussung unterschiedlicher Algorithmen durch hohe Anteile an Harmonischen ist mit Hilfe von Simulationen theoretisch untersucht worden. Eine praktische Prüfung fand im Netzschutzlabor an der Otto-von-Guericke-Universität statt.

In Kapitel 6 sind die Netzschutzkonzepte beispielhaft an zwei Verteilungsnetzen, jeweils vor und nach der Anbindung von DER präsentiert und verglichen worden. Die Probleme der heutigen Netzschutzkonzepte in Inselfall werden gemeinsam mit einigen Lösungsstrategien präsentiert.

Kapitel 6 erläutert auch die Netzschutzkonzepte für Verteilungsnetze mit hohem Anteil an DER. Diese Konzepte basieren auf dem neuen Standard für das Substation Automation System-IEC 61850. Das zweite Konzept präsentiert eine Idee eines Netzschutzkonzeptes in Verteilungsnetzen mit zusätzlicher Signal-Injektion.

Die Untersuchungen sind mit der Realisation eines E-learning Kurses in dem Bereich Digitaler Netzschutz abgerundet und in Kapitel 7 dargestellt. Dieser E-learning Kurs ist zusätzlich in den Lehrgang im Bereich

Netzschutz und Hochspannung an der Otto–von–Guericke-Universität aufgenommen worden.

3. Digital protection in distribution networks

3.1 General information about protection systems

A general requirement of any power supply system is that it has to be well designed and properly maintained in order to achieve an acceptable level of reliability, quality and economic price of the electricity supplies as well as to limit the number of faults that might occur during operation. A number of ancillary systems are present in the distribution systems to assist in meeting these requirements. The most important of these are the protection systems, which are installed to clear faults in network operation and limit any damage to distribution network equipment [1]. Automatic operation of protection systems is necessary to isolate faults on the networks as fast as possible in order to minimise damage. The economic costs and benefits of a protection system must be considered in order to present a suitable balance between the requirements of the protective scheme and the available financial resources [2]. The requirements set to the implemented protection system may be summarised in the following:

- reliability: the ability of the protection to operate correctly. It has two elements: dependability – a certainty of correct operation when a fault occurs, and security – an ability to avoid incorrect operation ;
- speed: minimum operating time to clear a fault in order to avoid damage;
- selectivity: maintaining continuity of supply by disconnecting the smallest possible section of the network necessary to isolate the fault;
- costs: maximum protection capabilities at the lowest price possible.

A compromise is required to obtain the optimum protection system. A properly coordinated protection system is necessary to ensure that an electrical distribution network can operate within the requirements for safety of equipment, staff and public, and the network overall [3].

3.2 General information about numerical protection

The former protection systems have used protective relays and worked according to the law of electromagnetic force. After wide implementation of the microprocessor technique, the numerical protection systems were introduced. Numerical protection devices operate on the basis of sampling inputs and controlling outputs to protect or control the monitored system. Network currents and voltages are sampled one at a time [1]. After acquiring samples of the input signals, calculations are realised in algorithms to convert the sampled data into a final decision in order to identify a fault. The numerical protection devices are multifunctional and can be regarded as intelligent electronic devices (IEDs). Programmable input-output (I/O), extensive communication features and an advanced human-machine interface (HMI), provide easy access to the available features [2]. Here are some of the characteristics of numerical protection devices:

- reliability: lower incorrect operations compared with the conventional protection devices;
- self- diagnosis: is realised as a watchdog circuitry, which includes memory checks and analogue input tests;
- event and disturbance records: by a realised protection function, energising of a status input, hardware failure. Records include also all status input and output information;
- integration of other digital systems: e.g. communications, measurement and control for a reliable substation operation;
- adaptive protection: the settings of the protection device can be changed according to the operational conditions of the network (real time situations).

In the following section a typical structure of a numerical protection device is discussed. The main modules are:

- microprocessor: responsible for processing the protection algorithms. It contains the memory module, which includes the following components:

- RAM (random access memory) with the functions: retaining the information data that is input to the processor and is necessary for storing information during the calculation of the protection algorithms.
- ROM (read only memory) or PROM (programmable ROM) for storing programs permanently.
- input module: for receiving the input signal and proceeding them to the microprocessor. The module contains: analogue filters, realised as low band pass for elimination of higher harmonics; signal conditioner which converts the signal from the current transformers (CTs) into a DC signal; analogue/digital (A/D) conditioner: which converts the DC signal into a digital signal which is then sent to the microprocessor, or communications buffer.
- output module for: sending the microprocessor response signals to the external elements (e.g. tripping command to a circuit breaker).
- communications module: contains series and parallel ports to permit the interconnection of the protection device with the control and communication systems of the substation.

The basic structure of a digital protection device is presented in Fig. 3.1.

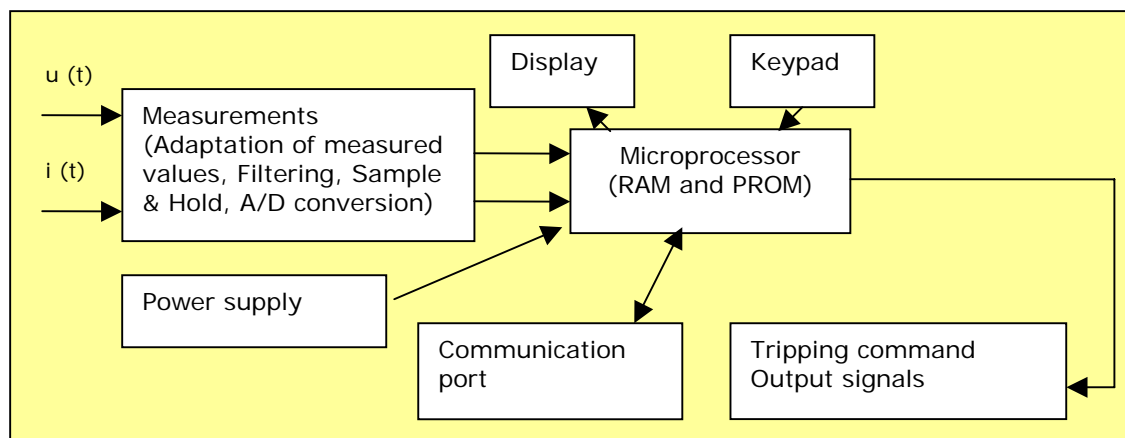

Fig. 3.1: Basic structure of a digital protection device

The most important standard functions of numerical protection devices are [3,4]:

- protection functions: directional/non-directional three-phase over-current; directional/non-directional earth-fault current; negative-

phase-sequence over-current; directional power; over-excitation; over- and under-voltage; over- and under-frequency; distance; differential; breaker failure; breaker monitoring and automatic re-closing;

- measurement functions: three-phase voltages and currents are measured, digitally sampled, and the fundamental component is extracted using a discrete Fourier transformation (DFT). Frequency, power factor, apparent power, reactive and active power can also be measured;
- control functions: for sending a tripping command to the circuit breaker;
- communication: A communication port on the protection device front panel provides a temporary local interface for communication. Communication ports and the panel provide a permanent communication interface. Panel communication ports can be connected to computers, terminals, serial printers, modems, and intermediate logic communication/control interfaces.

3.3 Functional principle of over-current protection

Over-current protection is one of the most used protection principles implemented as a protection of: power lines, cables, transformers and motors. This type of protection can be used as a primary as well as a back up protection (Fig. 3.3). Used as a primary protection, the over-current protection has the task of sending an immediate tripping command when the fault is inside the protective zone, and as a back up protection to send the command after a set graded time (if the primary protection for the fault hasn't reacted). For implementation in a network with multiple infeeds, a direction criteria is necessary [5].

There are two principles of over-current protection: definite-current and inverse time principle (Fig. 3.4). The definite-current protection device operates instantaneously when the current reaches a predetermined value ($I >$, $I >>$) and the set time has passed ($T_{I>}$, $T_{I>>}$). The setting is chosen so that, at the substation furthest away from the source, the protection

device will operate for a low current value and the protection device operating currents are progressively increased at each substation, moving towards the source. Thus, the protection device with the lowest settings operates first and disconnects load at the point nearest to the fault. This protection is not very selective at high values of short circuit current [6].

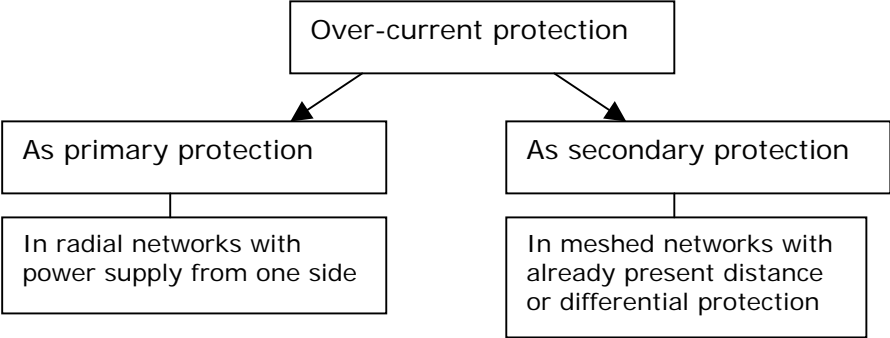

Fig. 3.3: Implementation of over-current protection

The fundamental property of the inverse time protection devices is that they operate in a time which is inversely proportional to the fault current. Their advantage over definite time, and definite current protection devices is that, for very high currents, much shorter tripping times can be achieved without a risk to the protection selectivity. They are also divided into inverse, very inverse and extremely inverse [5].

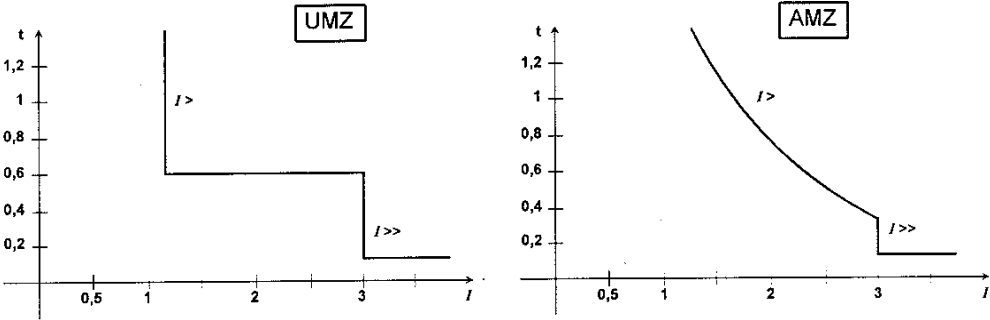

Fig. 3.4: Types of over-current protection

3.4 Functional principle of distance protection

Distance protection is one of the most important types of network protection, concerning protecting a line. The distance protection device is connected generally via voltage and current transformers to the protected line [2]. The distance protection device monitors this line, if a fault on the line occurs it should send an immediate tripping command to the circuit breaker on the line to trip. The system of distance protection is presented in Fig. 3.5. All of the system components must be present in the scheme to fulfil the protection task [4].

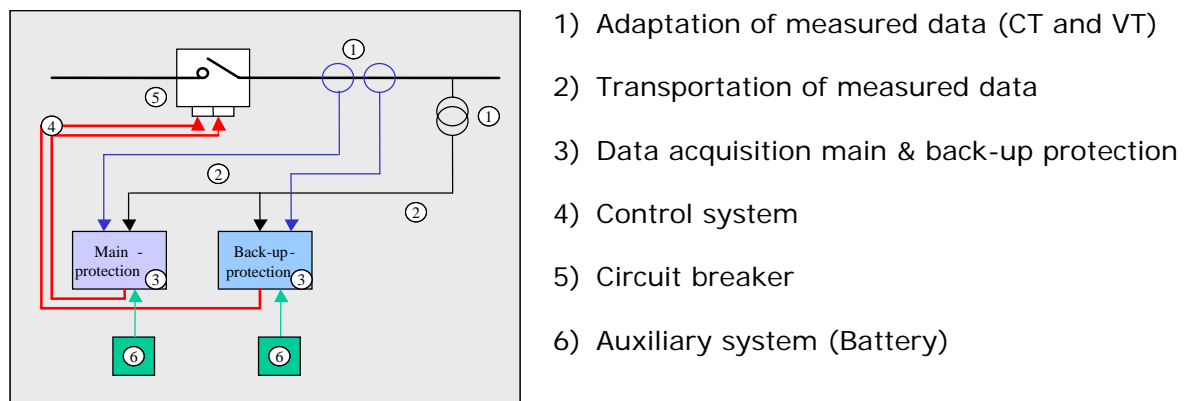

Fig. 3.5: System components of the distance protection device

The selectivity of disconnection is achieved by calculating the distance from the placing point of the protection device to the fault. Using time grading the distance protection can be used as a back up protection for further line parts or other upcoming lines [8]. The distance protection device can also be set in two directions: forward (as shown in Fig. 3.5 and Fig. 3.6), and reverse, for example as a backup protection for a generator, or transformer [4].

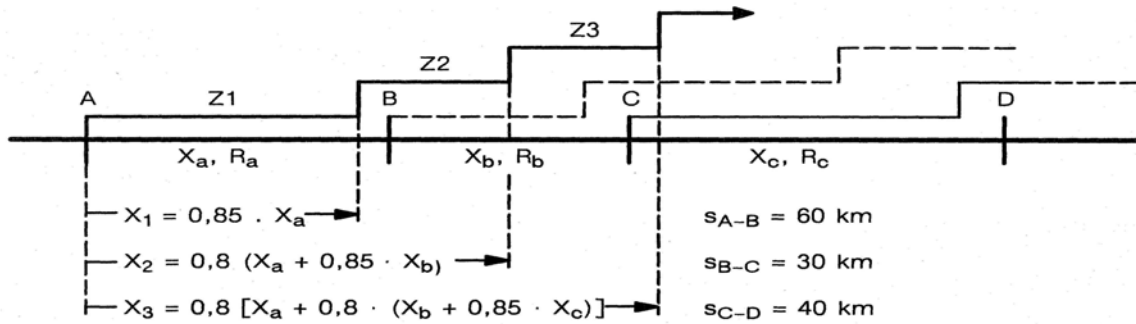

Fig. 3.6: Protection zones of the distance protection at bus bar A

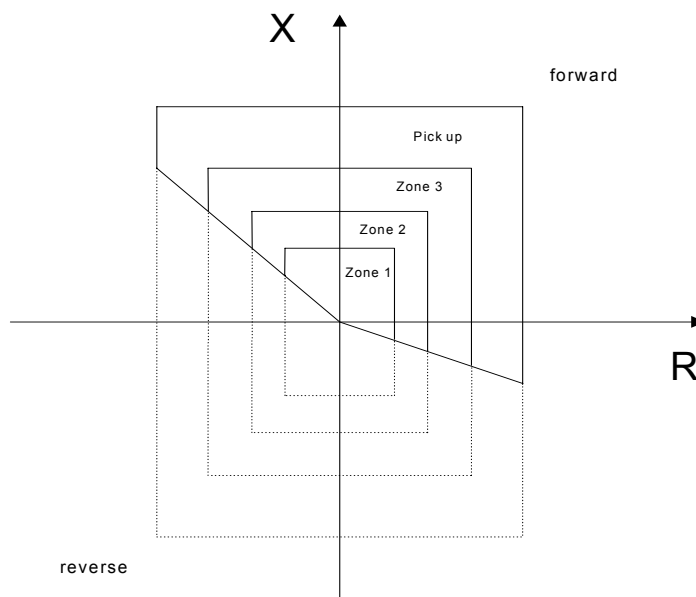

Fig. 3.7: Tripping characteristic of a distance protection device

For calculating the distance to fault (impedance) the distance protection device needs the input values of the three-phase voltage and current, which can be measured at the placing point of the protection device (3.1). A total of 6 voltages and 6 currents values are measured (phase to phase and phase to neutral values).

$$\underline{Z} = \frac{\underline{U}_{\text{meas}}}{\underline{I}_{\text{meas}}} \quad (3.1)$$

With the calculation of the impedance, the distance to fault can also be calculated. The tripping command is sent when the calculated value of the impedance is within the specially designed and paramertised tripping characteristic (Fig. 3.7). In Fig. 3.7 a polygonal characteristic is

presented. Some distance protection relays also use MHO (inverse Ohm) characteristics, cycle characteristics, etc.

3.5 Functional principle of differential protection

Differential protection is connected on both terminals of the protected element via current transformers (Fig. 3.8). The functional principle of this type of protection is to send an immediate tripping command to both circuit breakers only when the fault is within of the protective zone [3]. This protection should not operate for external faults (no back up protection function is possible).

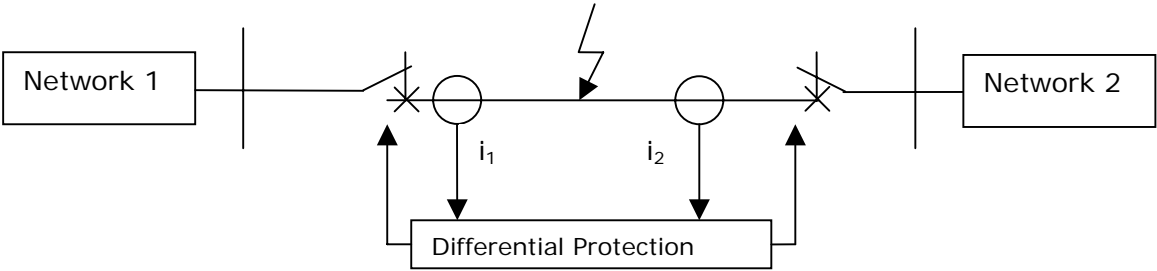

Fig. 3.8: Functional principle of differential protection

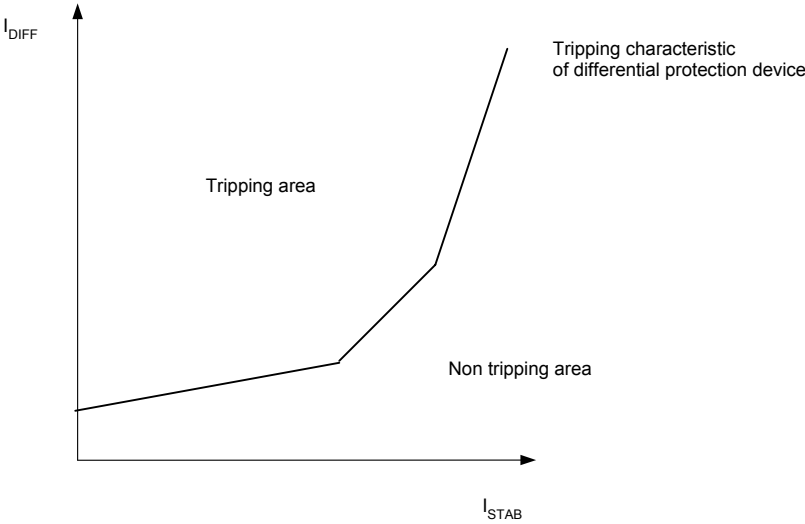

Fig. 3.9: Tripping characteristic of a differential protection device

The functional principle of the differential protection is based on the electromechanical principle of balancing. Two parameters are defined: differential current (3.2) and stabilising current (3.3), defined as follows:

$$\text{Differential current:} \quad I_{\text{DIFF}} = | I_1 + I_2 | \quad (3.2)$$

$$\text{Stabilisation:} \quad I_{\text{STAB}} = | I_1 | + | I_2 | \quad (3.3)$$

The tripping characteristic is presented in the function (3.4).

$$I_{\text{DIFF,pick up}} = f(I_{\text{STAB}}) \quad (3.4)$$

This type of protection has very high selectivity, high speed and is mostly used for protecting transformers, generators, and short lines (distance protection is not easy to realise). The differential protection can be realised either as a comparison between moment values of the two measured signals or as a comparison of the phases of the two measured signals. The disadvantage of using the differential protection is the need of pilot wires for communication between both protection devices forming the differential protection principle [5].

4. The implementation of DER in the network and its influence on digital protection

4.1 Introduction. General information of the technologies of DER

Since the beginning of the 1990s the concept of „sustainability“ has been the topic of discussions, when the topics of sparing acquaintance with the nature and the worldwide justifier distribution of the prosperity and wealth matters. With this the concept sustainable development includes and considers ecological, economical and social aspects [27,28]. The motto of sustainable development is, that „the lifestyle demands of the generations of today should be fulfilled without reaching after the possibilities of the future generations“. After the liberalisation of the energy markets, the power companies were confronted with each other and the energy customers got the freedom of choice for the question of power supply. The utilities are confronted with the following:

- accomplishment of the increasing energy import dependancy;
- managing the energy mix and climate protection goals;
- improving energy efficiency while at same time reducing the energy costs;
- equal treatment of the energy political goal triangle - security of power supply, cost effectiveness and environmental compatibility.

With the striving towards ecological goals and resources sustainability, the DER are becoming more and more important. The usage of renewable energy is based on a simple principle, obtaining power from natural energy flows like wind, water, sunlight. Under renewable resources every form of energy is to be understood that has neither a fossil nor nuclear source; i.e. sun energy, wind energy, biomass, geological heat, tide energy, water energy. In the following some examples of today's usage of DER in Germany [27,28] are given:

- The photovoltaic market is currently only for some applications up to 5-10 MW because of the high costs,

- The micro turbines implemented by the small water power plants and the fuel cells implemented by the combined heat and power plants, are maybe not yet economically acceptable but, they do represent themselves with a high growth rate.
- The very popular and economically efficient wind energy usage in the Onshore- and Offshore-parks has already reached the value of 16 GW.
- The fuel cells furthermore have been seen as a big part of the future energy mix, as well as in the automotive industry.

The reasons for the above-described development of the DER technologies are: the implementation of micro turbines (mostly used by DER) with high efficiency (85%), low emissions (< 15 ppm NO_x and CO₂), flexibility in fuel usage: oil, diesel, gas, biogas, methanol, hydrogen; small maintenance costs (power electronic devices (inverter) and high speed motor), and remote control for power generation is possible [29].

Typical implementation can be seen in commercial/manufacturing industry, hospitals, private houses, shopping centres, etc. The micro turbines will be implemented in the medium (MV) and low voltage (LV) networks via inverters. For example, the fuel cells can be implemented in private houses and similar facilities as a substitution for gas heating. The installed power is between 5 kW and 250 kW.

In Europe about 14% of the total energy generation is provided by DER (from them 3,2% from water power plants and 4% wind energy). The EU-goals for the year 2020 are to reach DER generation of about 22% of the total energy generation, with 12,5% water power and 8% wind energy [28].

In this chapter in section 4.2 the theoretical analyses of the connection of DER on the distribution network are presented. In section 4.3 the modelling of DER for protection coordination tasks are given.

4.2 Connection of DER to the network

The first idea of decentralised energy generation and consumption originated from Thomas Edison, as he in 1882 completed one block Heat-

Power station. The idea was the realisation of one area supplied from micro power stations. Today, more than 120 years later, this unique idea is becoming more and more present in the electricity networks. One of the reasons lies in the liberalisation of the energy markets. The idea of the liberalisation brought lots of small, local power plants to the energy market which characterise themselves with low investment costs in comparison to the big coal and nuclear power plants. These small power plants have the possibility of offering cheaper energy to the customers compared to the conventional power generation, mostly because of the smaller power transmission costs [30]. Also these small power companies are closer to the energy customers and have the possibility to offer a better service, which is one of the most important things in the competitive energy market. One other reason for growth of the implementation of DER on the network lies in the customer demand of a sustainable continuous energy supply. And the third reason is the governmental support of DER in connection with the clean environment. With these reasons slowly, but surely, the energy generation, transmission and distribution system is moving towards a power system with lower power losses realised with small energy units connected to the power transmission and distribution system, instead of the traditional and conventional energy cycle [31].

But, it must be seen that this actually means that the DER are and can only be an addition to the conventional energy generation. They are implemented on the MV or LV level, close to the customers, with a size between 1 MW and 50 MW. The implementation of DER in the network needs an implementation of a special control centre that regulates, controls and supervises the load management, energy flow management and voltage control, since most of the DER do not contribute to the voltage and frequency control. This system has to fulfil the functions of maintenance, protection and supervision of the whole power system. Also the functionality of the „micro network“ realised with DER must be coordinated and optimised in the local control centre. This local control centre can also be connected to an energy market centre for sale and purchase of energy.

The design of the connection of the DER to the network is to be made according to the requirements of the existing power system. With the implementation of DER, a new situation concerning the power system

operation, for example the load flow can be observed. Concerning the load flow, the connecting line between the power system and DER transforms itself in a bi-directional power link concerning the ratio of energy generation and energy demand.

Due to the way the DER are connected in the network, it may be possible that the existing network protection may cause operation of the circuit breakers in the network. For example, this might be the case when the tripping parameters of the implemented over-current, or distance protection are set without direction criteria. Similar function can also be possible by the protection devices that function according to the criteria voltage. On the one hand, the protection devices that function according to the principle of over voltage may give a tripping command to the circuit breaker when the injected power of the DER is higher than the power demand of the connected energy consumers. On the other hand, the protection devices that function according to the criteria under voltage may give a tripping command when the DER are disconnected from the network.

As protection units in networks with DER the following protection devices that use the operational principle current and/or voltage are implemented: time graded over-current, voltage-restrained over-current, instantaneous or time graded earth fault, neutral voltage displacement, differential protection and reverse power. For the generator: over-speed, under voltage, vibration detection (protection from mechanical failure together with devices that detect winding, bearing or over temperature).

In case of fault in the main network (islanding operation of DER), or when the network frequency or the network voltage find themselves outside the allowed ranges, some DER are supposed to be disconnected. This is a result of the missing control systems for voltage and frequency stability of the network, by islanding operation of DER. These DER are also not to be re-connected to the network until the fault in the network is cleared. This sets the requirement of a good parameterised network protection and auto re-closure.

Some problems according to the selectivity of the network protection are discussed in the following two examples. In Fig. 4.1a the connection between the DER and the network (EES) is realised with one line. A fault inside the protection zone of the protection devices on this line - F1 must

be cleared very fast, because in this case, the DER is disconnected from the network and a fault outside the protective zone - F2 should not disable the connection between DER and the power system. As criteria for the settings of the protection device in the example network, the voltage and current measurements under different network situations should be taken at a few nodes.

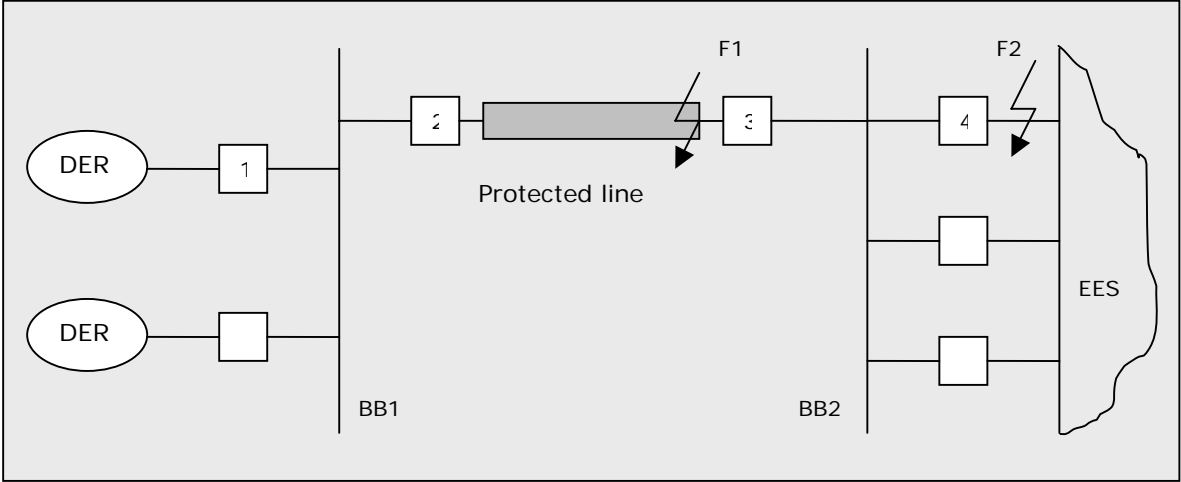

Fig. 4.1a: Connecting DER on one side of a network

In the presented example only the protection devices numbered with 1, 2, 3 and 4 are taken into consideration during the analysis. In the case of fault F1 the protection devices 2 and 3 should immediately clear the fault and with that the power system and DER are divided. In the case of fault F2 the protection device 2 must wait for the protection device 4 to clear the fault F2. A communication channel between the protection devices 2 and 3 is necessary for sending a blocking command or time delay to the device 2 in the case of fault F2.

With regard to the settings of protection devices, a distinction needs to be made between the maximum and the minimum value of the short circuit current. The minimum value occurs when the main power supply is disconnected from the network and the fault is fed only from DER. The problem that may occur in this situation is when the highest operational current has a higher value than the minimum short circuit current coming from DER. With the time gradation of the over-current protection the tripping command can be delayed and with that the impedance of the generator will become bigger e.g. from the value of sub transient into the

value of transient operation. The generator current will change itself in the same sense and will be used as tripping criteria. With the time delay the network stability can be questionable, because the generators may be brought into a swinging state. The power line, if it is a few kilometres long, can be protected with a differential protection. For longer lines the investments for the pilot wires play a role in the decision-making.

In the case of energy supply from multiple sides (Fig. 4.1b) the problems for correct settings of the protection devices increase. The settings of the protection device 1 have to be made very carefully considering all possible network stages. In the network there are different generators with different power in feed, connected in parallel.

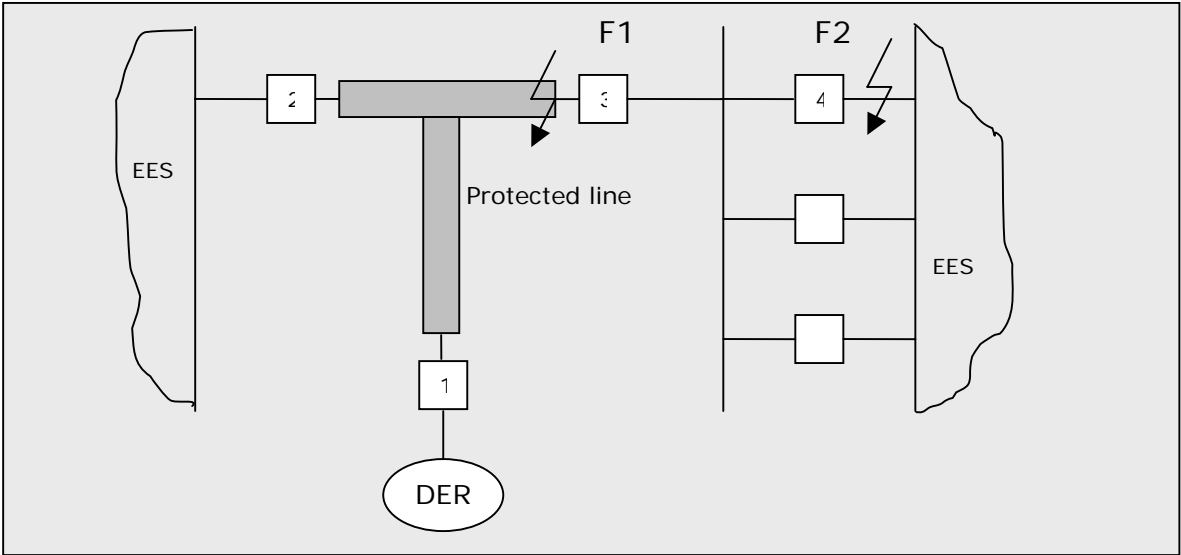

Fig. 4.1b: Multiple power supply and DER

The line between the protection systems 1 and 2, before the connection of DER to the network can be realised as directional over-current protection, which is typical for double-sided in feed. With the implementation of DER to the network a so called T-connection has been accomplished in the network. In this situation, in the case of a fault in the network, the implemented protection is not enough. A possible way to protect the lines in this case is with a protection using the criteria of impedance for each protection system with forward and backward fault location option with a precise definition of the protection zones or by multi terminal differential protection.

In the following some characteristics of two types of networks are listed [39]:

Meshed networks:

- high short circuit capacity;
- stable voltage in the network at all nodes;
- insensitive to load change;
- high security and redundancy.

On these networks DER can be implemented as long as the short circuit capacity doesn't confront any dimensioning criteria of the used equipment. The problems which can occur are the settings of the protection devices.

Radial networks:

- low short circuit capacity;
- unstable voltage if a fault in the network occurs;
- very sensitive to load change;
- low security and redundancy.

The implementation of DER on these networks will influence the network state greatly. Easy realisation of the settings of the network protection is possible by using only time gradation over-current protection.

The influence of the implementation of DER on the network can be summarised as follows:

- When the total generated power from DER is smaller than the connected load, then the needed power from the power system is smaller and with that the transmission costs, transmission losses and the voltage drop on the transmission lines will be smaller. The voltage on the user side is more stable than without DER on the network.
- When the total generated power from DER is equal to the connected load, then the transmission costs, transmission losses and the voltage drop on the transmission lines are minimal.
- When the total generated power from DER is higher than the connected load, then it has to be checked if the dimensioning

criteria are fulfilled, if not, then the energy injection from DER must be limited.

One meshed network with the opening of the circuit breakers can be operate as a radial network. This procedure can be necessary when the short circuit capacity after the implementation of DER on the network over reaches the dimensioning frames of the network elements. With this action the short circuit capacity will become smaller at all nodes in the network and this also provides the possibility for better selectivity of the protection devices.

The problem of cost saving

The liberalisation of the electricity market has clearly brought an increased pressure on the power system management to reduce the cost of energy generation, transmission and distribution. All utilities from the area of power systems in liberalised market must achieve a reasonable profit in order to stay in the market [29]. This means setting targets with cost saving goals in areas like human resource costs, maintenance costs, and plant investment. The human resource costs are between 30 and 60% of the total costs of a distribution power system [38]. With this high percentage of cost this area deserves to be paid special attention. The determination of the maintenance requirements depends mostly on the installed technology and is based mainly upon the company's established strategies. These strategies follow the company traditions and the results of the long years of operational experience. The operational experience contains the knowledge of the fault events, inspection results, etc, in the utility's network. The reduction of the costs in the area of maintenance, as well as the use of new digital technology, can be seen in synergy effect. Namely, as an exchange of experience between the personnel of different utilities.

Due to the stagnating demand for electrical energy in the highly developed countries, capacity increases or power system structural changes are only necessary on a point by point basis and by the changing requirements of the connected customers. The situation of energy demand in the developing countries is completely different e.g. China. Taking the limited energy resources e.g. coal, oil, gas, into account, the dependability

of DER is becoming important. The implementation of DER in the power system will bring some changes connected also with benefits and costs for the utilities and customers. Some of the problems that might occur at sight are more complex power system protection schemes, connected with that higher costs. But, the implementation of the new concepts and products will take place over the next two decades, which corresponds to the historical range of the technology and products that exist today in the distribution power system [38].

The problem of islanding

Disconnecting the main power supply from the network creates island network supplied only by DER [32]. This effect, in a sense of security in the power supply, might be allowed. But, it brings also problems with it, for example:

- safety of devices and people;
- control, communication and coordination of the functions of the DERs for the island;
- not all DER are able to feed islands with free frequency.

Concerning the control, for example, the voltage can no longer be controlled from the main power supply and EES, although the EES is still obligated to fulfil this service to the energy customers [33]. The protection devices in the constructed island are not set for this state of the network, being parameterised for the requirements set by the main power supply. Further, the island network might not be earthed properly. In a competitive energy market no electricity supply might be very expensive for the energy sellers. In this case, a solution for this problem must be found, since critical situations can occur if a part of the utility network is islanded and an integrated DER unit is connected. This situation is commonly referred to as Loss of Mains (LOM) or Loss of Grid (LOG). When LOM occurs, neither the voltage nor the frequency are controlled by the utility supply. Normally, islanding is the consequence of a fault in the network. If an embedded generator continues its operation after the utility supply was disconnected, the fault may not be cleared since the arc is still charged. Small embedded generators (or grid interfaces respectively) are

often not equipped with voltage control, therefore the voltage magnitude of an islanded network is not kept between desired limits, and undefined voltage magnitudes may occur during island operation. Another result of missing control might be frequency instability. Since real systems are never balanced exactly, the frequency will change due to active power unbalance. Uncontrolled frequency represents a high risk for machines and drives.

Since arc faults normally clear after a short interruption of the supply, automatic (instantaneous) reclosure is a common relay feature. With a continuously operating generator in the network, two problems may arise when the utility network is automatically reconnected after a short interruption. The fault is not cleared since the arc is fed from the DER unit, therefore instantaneous reclosure may not succeed. In the islanded part of the grid, the frequency may have changed due to active power unbalance. Even if there is active power control, the island will not run synchronously with the utility system. Reclosing the switch would couple two asynchronously operating systems.

Extended dead time has to be regarded between the separation of the DER unit and the reconnection of the utility supply to make fault clearing possible. Common off-time settings of auto reclosure relays are between 100 ms and 1000 ms. With DER in the network, the total off-time has to be prolonged. A reclosure interval of 1 s or more for distribution feeders with embedded generators.

LOM and automatic reclosure are some of the most challenging issues of DER protection and therefore a lot of research has been done in that area. The only solution to this problem seems to be disconnecting the DER unit as soon as LOM occurred. Thus it is necessary to detect islands fast and reliably.

If a DER unit is connected via a grounded delta-wye transformer, earth faults on the utility line will cause ground currents in both directions, from the fault to the utility transformer as well as to the DER transformer. This is normally not considered in the distribution system ground fault coordination. Whenever the utility earth connection is lost, the whole system gets ungrounded.

Current Practice - Island Detection

To prevent island operation, the protection system has to detect islands quickly and reliably. This is the task of loss of mains protection. The methods for island detection are divided into passive and active methods. Some of them will be outlined in the following sections.

1) Passive Methods

These methods detect loss of mains by passively measuring or monitoring the system state.

- Under-/Overvoltage

A clear indication of lost utility supply is very low voltage. If there are uncontrolled generators in the network, the voltage can also rise (for example due to resonance) and exceed the upper limit. Therefore, under- and overvoltage relays are a simple islanding protection method. In larger islands the voltage collapse will take some time, therefore this kind of LOM protection is often too slow.

- Under-/Overfrequency

Real systems are never balanced exactly. After LOM happened, the frequency in the island changes. Hence frequency out of limits can indicate island operation. The frequency does not change instantaneously but continuously, thus frequency relaying is a rather slow method.

- Voltage Vector Shift

This is also referred to as phase displacement or phase jump method.

- Rate of Change of Voltage

Usually voltage changes are slow in large interconnected power systems. If a distribution system gets separated, a rate of change of voltage occurs that is significantly higher than during normal operation. Therefore rate of change of voltage can be used to detect island operation. A major handicap of this method is that it is sensitive to network disturbances other than LOM.

- Rate of Change of Frequency

The frequency in an island will change rapidly due to active power unbalance. The corresponding frequency slope can be used to detect loss

of mains. Whenever df/dt exceeds a certain limit, relays are tripped. Typical pickup values are set in a range of 0.1 to 1.0 Hz/s, the operating time is between 0.2 and 0.5 s.

- Rate of Change of Power and Power Factor

The instantaneous power is derived from the generator voltages and currents and then the rate of change of power is used in a limiting function that prohibits mal-function due to system disturbances.

2) Active Methods

Beside passive measurements and monitoring, there are active methods of LOM detection where the protection system is actively interacting with the power system in order to get an indication for island operation.

- Reactive Error Export

The generator is controlled on a certain reactive power output. Whenever islanding occurs, it is assumed that it is not possible to deliver the specified amount of reactive power to the local grid since there is no corresponding load. This reactive export error is taken as an indicator for LOM.

- Fault Level Monitoring

The fault level in a certain point of the grid can be measured using a point-on-wave switched thyristor. The valve is triggered close to the voltage zero crossing and the current through a shunt inductor is measured. The system impedance and the fault level can be quickly calculated (every half cycle) with the disadvantage of slightly changed voltage shape near the zero crossover.

- System Impedance Monitoring

This method detects LOM by actively monitoring the system impedance. A high frequency source (a few volts at a frequency of a few kHz) is connected via a coupling capacitor at the interconnection point.

- Frequency Shift

Inverter-interfaced DER can be protected against LOM using frequency shift methods. The output current of the inverter is controlled to a

frequency which is slightly different to the nominal frequency of the system. This is done by varying the power factor during a cycle and re-synchronization at the begin of a new cycle. Under normal conditions, the terminal frequency is dictated by the powerful bulk supply. If the mains supply is lost, frequency will drift until a certain shutdown level is exceed.

- Voltage Pulse Perturbation and Correlation

Two methods of islanding detection for inverter-connected DER are presented that use a perturbation signal of the output voltage. For the first method, the inverter output is perturbed with a square pulse. This square pulse appears in both the inner voltage of the source and the voltage at interconnection point. If islanding happens, the apparent impedance at the generator terminal increases and therefore the perturbation can be measured at the point of common coupling (PCC) (similar to system impedance monitoring). The second method uses a correlation function to detect LOM. The inner voltage of the source is randomly perturbed and correlated with the voltage change at the interconnection point. During normal operation, the apparent impedance is low and the voltage waveform at the interconnection point will not reflect the perturbation signal. After islanding the modulation signal will appear in both the inner voltage and the voltage at the interconnection point what results in a strong correlation.

- Interconnect vs. Generator Protection

Protection concerns both the distribution grid as well as the distributed generator itself. Therefore protection schemes have to be implemented on both sides of the PCC. The whole protection system is split into two parts: interconnect protection and generator protection. The interconnect protection protects the grid from the DER unit, i.e. it provides the protection on the grid-side for parallel operation of the DER and the grid. The requirements for this part are normally established by the utility. The generator protection is installed at the generator-side of the PCC and protects the DER from internal faults and abnormal operating conditions. Usually, the utility is not responsible for this kind of protection.

Examples of State-of-the-Art Relays

A number of companies are offering generator protection and control systems. Four examples of generator protection devices are present on the market [97]: integrated generator protection; loss of mains relay; integrated genset control device and general electric universal interconnection device (see Fig. 4.2).

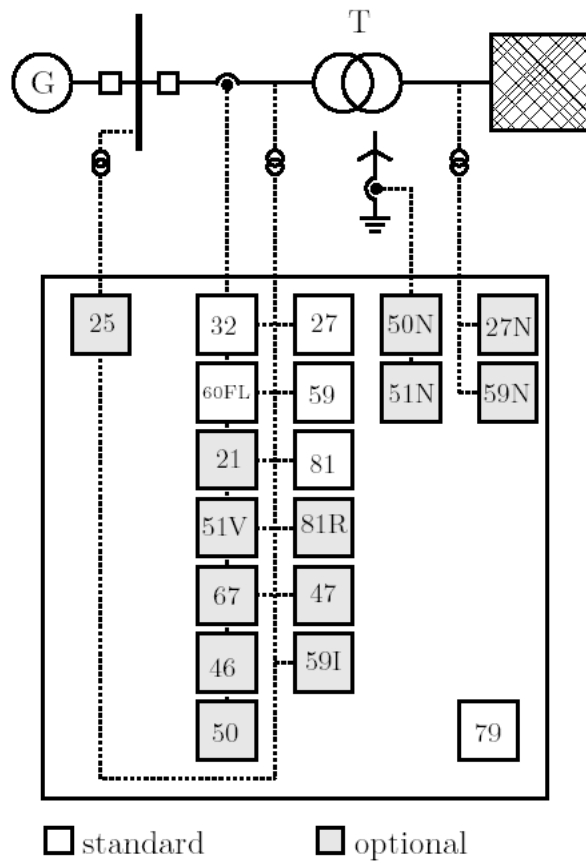

Figure 4.2: Typical multifunction interconnect relay [97]

Table 1: Explanation of relay numbers

Number	Application
21	Distance
25	Synchronizing
27	Undervoltage
27N	neutral undervoltage
32	directional power
40	loss of excitation
46	neg. seq. current
47	neg. seq. voltage
50	instantaneous overcurrent
50N	neutral instantaneous overcurrent
51N	neutral time overcurrent
51V	voltage-restrained overcurrent
59	Overvoltage
59I	instantaneous overvoltage
59N	neutral overvoltage
60FL	voltage transformer fuse failure
67	directional overcurrent
79	Reclosing
81	frequency (under and over)
81R	rate of change of frequency
87	Differential
LOM	loss of mains

4.3 Modelling of DER for protection coordination tasks

The modeling of DER in the time interval of $0 < t < 100$ ms is interesting for testing the settings of the network protection.

4.3.1 Fuel cells modelling

Basically for the implementation of fuel cells (FC) in the technology of combined heat power production (CHP) in low temperature ranges the polymer electrolyte membrane (PEM) fuel cell is of interest. The electrical power in this temperature range can be between 1 kW and 1 MW. Bigger power plant units can be realised by coupling a few modules together. The FC is connected to the network via inverter, as presented in Fig. 4.3. On the output terminals of the FC, theoretically about 80% of the input energy in a form of electrical power can be gained and the remaining 20% is absorbed by the surrounding environment. Practically about 30-50% of the input energy can be gained in a form of electrical energy [86]. The PEM FC system contains the following components:

- reformer (for preparation of the fuel);
- FC (for electro chemical energy transformation);
- inverter (for electrical energy transformation);
- periphery devices: humidifier, circulation pump, reformer compressor and exhaust heat exchanger.

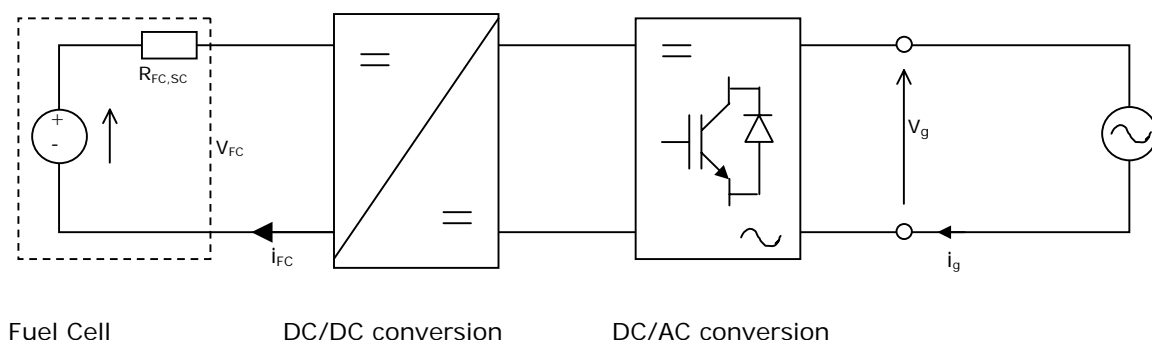

Fig. 4.3: Connection of the FC to the distribution network

For network protection purposes, no precise physical model of the PEM FC is needed, because its time constants are much higher than the network time constants in case of a fault as well as than time set for response of the network protection duration of $0 < t < 100$ ms.

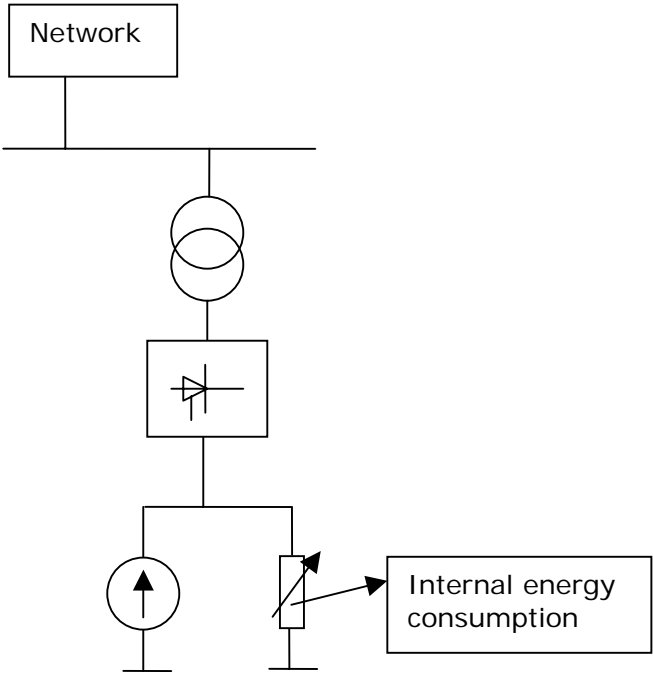

Fig. 4.3a: Connection schema of the FC to the distribution network

In this case the model of the PEM FC will mostly depend on the characteristics of the inverter through which the PEM FC is connected to the network. The inverter can be treated as a voltage controlled current source. In case of a fault in the network, the inverter controls will act within 10-15 milli seconds to protect in inverter electronics [99]. This means that the output current of the PEM FC is limited (see Fig. 4.3a).

4.3.2 Photovoltaic modelling

The photovoltaic units (PV) with the help of solar cells convert the sun light directly into electrical energy. This gained energy can be injected to the network via inverter. The electrical power of the PV can be easily scaled in the area of 100 Wp up to some MWp. The solar generator is

comprised of a few solar modules that are usually serially connected solar cells. The goal is here the voltage gradation.

The PV units also are connected to the network via an inverter (see Fig. 4.4). The solar generator together with the inverter are ready to inject electrical power into the network as soon as the solar generator has produced more energy than the losses of the inverter. The internal inverter also has the function of Maximal–Power–Point–Tracking, in order to optimally use the sun light. This function always sets the solar modules to operate in the maximum power point.

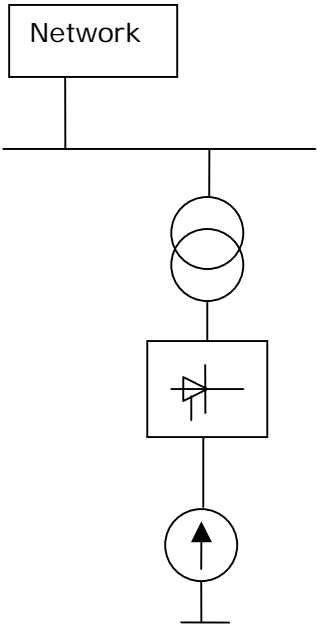

Fig. 4.4: Connection of the PV to the distribution network

Because of the very high time constants of the solar generator the PV units are modelled as voltage controlled current source.

4.3.3 Electrical energy storage devices modelling

The necessity of energy storage is becoming more important with regard to the following: constantly raising basic load in the networks, high energy costs during maximum load period, etc. Concerning the liberalisation of the energy markets and the principle of maximising the profit, the

mentioned problems are getting more important. The energy storage devices (ESD) once connected to the network, are providing the following services: balance of the maximal energy need, frequency stability, load balancing, and ready-to-use stored energy during blackouts. These characteristics bring advantages both to the energy producers and energy users. This also provides a possibility to reduce the energy transmission costs by energy losses. Nowadays the most used ESD is the Plumb-Acid-Accumulator. These devices are mostly used because of their price and their very good technical characteristics due to recent technology development. The ESD are also connected to the network via an inverter (Fig. 4.5). The modelling of EDS will be the same as the FC and PV.

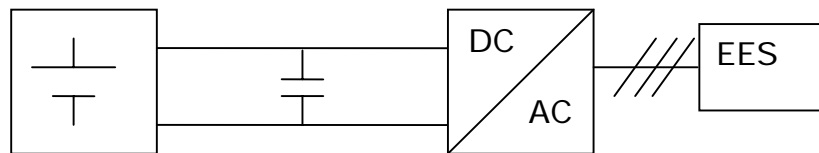

Fig. 4.5: Connection of energy storage devices to the network (EES)

4.3.4 Wind power plants modelling

There are several possibilities for connecting wind power to the network depending of their construction and the place of connection to the network, refer to [34-37]. In the MV networks, usually the wind power plants are connected via an inverter. The connection to the network via inverter sets the modelling characteristics for this type of DER as well (Fig. 4.6). This means that the same scheme (see Fig. 4.4) as for the PV unit can be used for modelling purposes [14].

The wind power plants can also be connected directly to the network (see Fig. 4.7) or via a double feed induction generator (DFIG) (see Fig. 4.8). The fault injection from DFIG (fault duration 350 ms) are given in Fig. 4.9 and Fig. 4.10. In this case the network calculations should be done as in networks with multiple in-feeds [37].

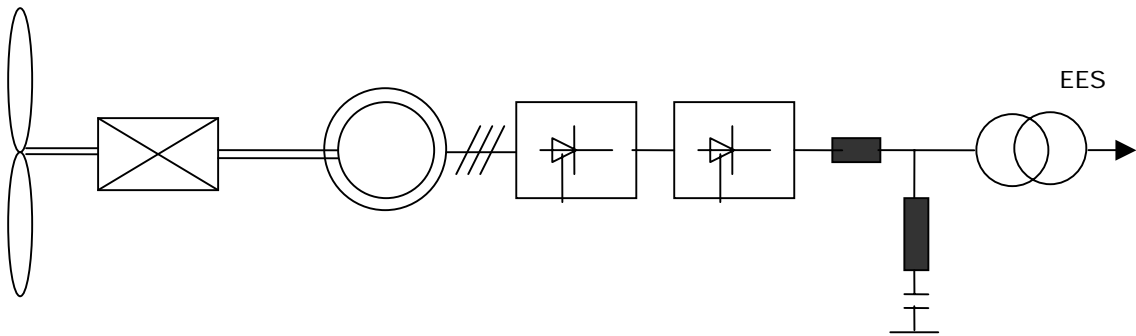

Fig. 4.6: Connecting a wind power plant to the network (EES) via inverter

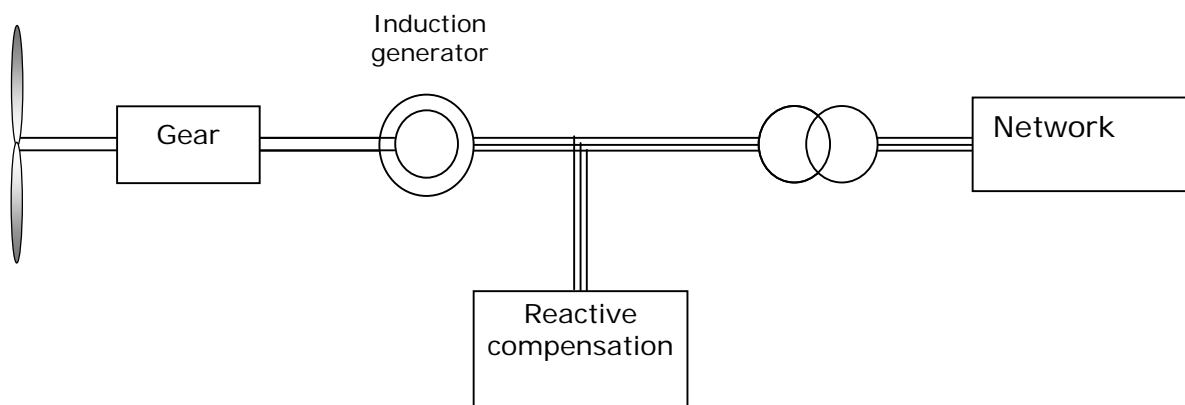

Fig. 4.7: Direct connection of a wind power plant to the network (EES)

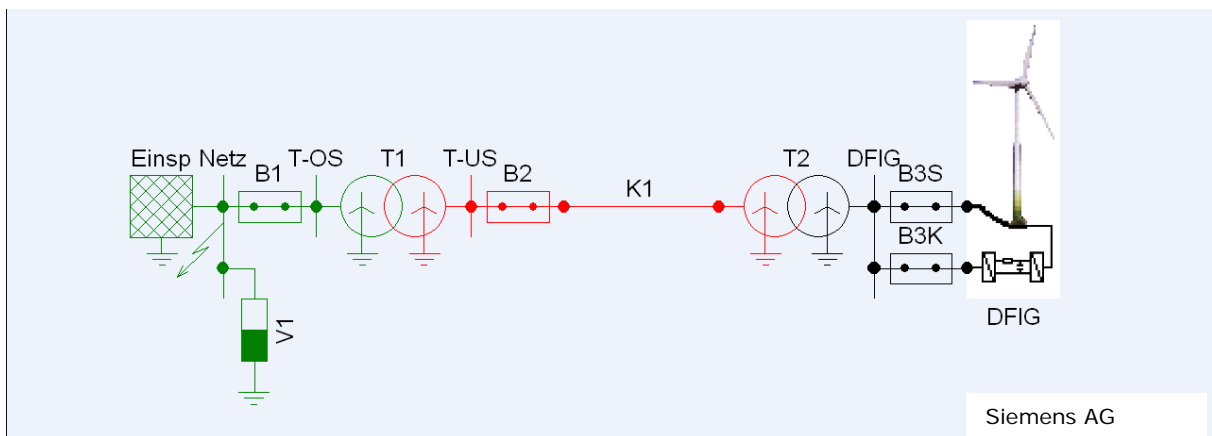

Fig. 4.8: Connection of a wind power plant to the network via DFIG

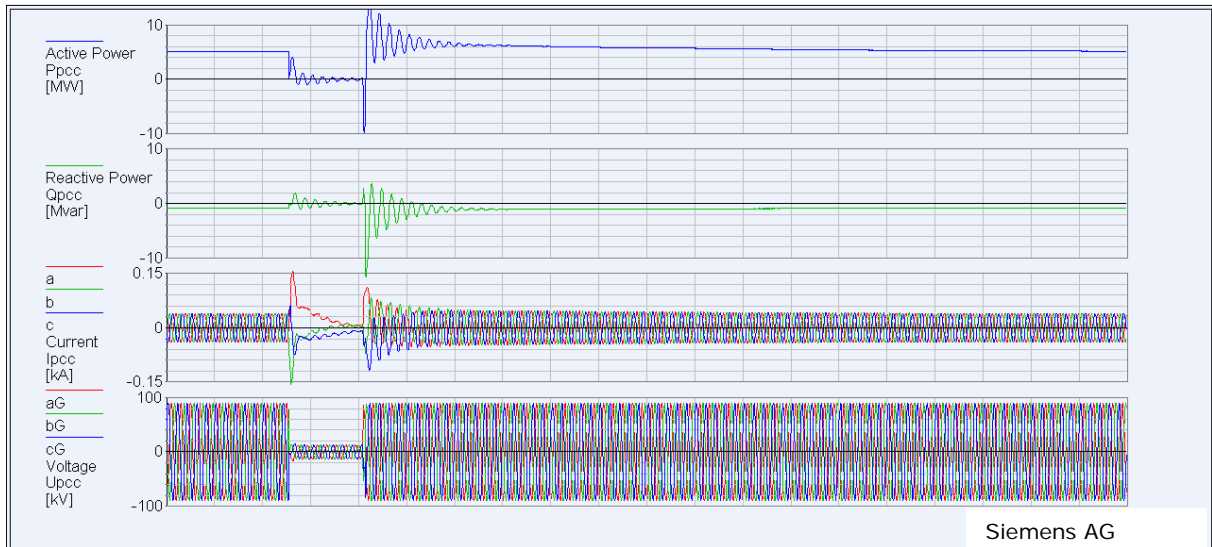

Fig. 4.9: Fault current calculation from DFIG with 15% residual voltage at PCC (active power, reactive power, fault current, voltage)

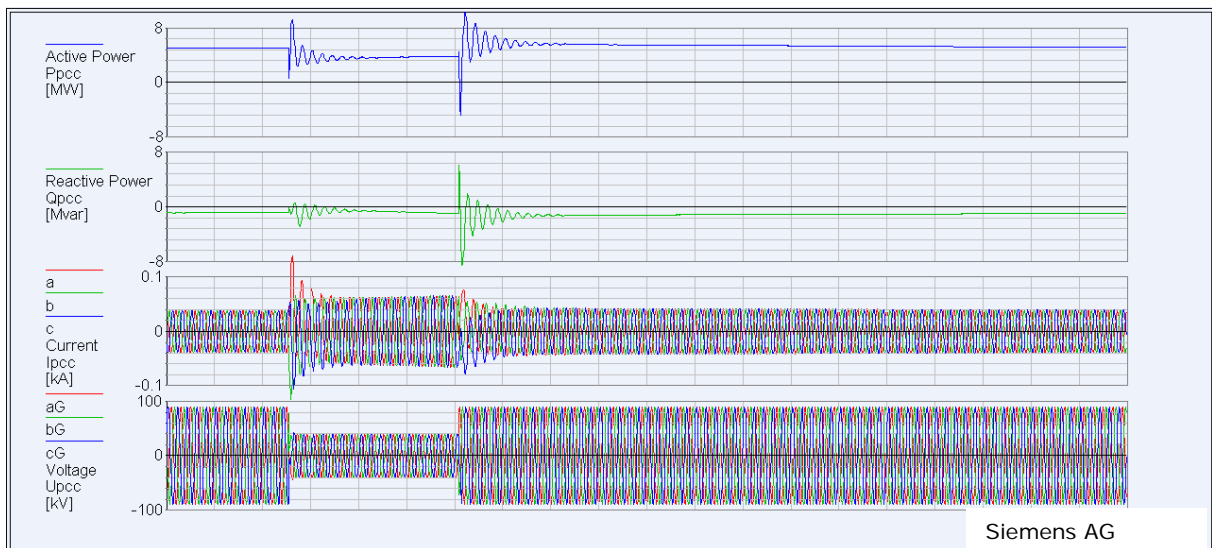

Fig. 4.10: Fault current calculation from DFIG with 50% residual voltage at PCC (active power, reactive power, fault current, voltage)

5. The influence of a high amount of harmonics on different types of protection devices

5.1 Introduction

The connection of DER to the distribution systems can lead to some problems concerning power quality [13]. Furthermore, the grading implementation of power electronic devices in the interfaces of DER and non-linear and non-balanced loads on the distribution system is expected to lead to a higher level of harmonics. Research on the behaviour of the protective relays in the new electrical environment requires knowledge, not only from the field of protection technique, but also from the following engineering disciplines: power quality, signal processing and computing, system state estimation, intelligent systems, etc. The new environment generates disturbances in voltage and current which do not appear due to a fault in the protected zone [14]. These disturbances may influence the calculations of the implemented algorithm inside the protection system and lead to an incorrect tripping command to the circuit breaker. This phenomenon has consequences on the threshold setting of the protection systems and their testing [15].

The detection and classification of the faults on a three-phase power distribution line (for example over-current, distance, under/over voltage, and differential) have been in practice for over 50 years. The theory of calculation of distance to fault using measured data from the three phases voltages and currents using measuring transformers has witnessed changes during this period of time, mostly influenced by signal processing, data evaluation and PC capabilities. Consequently, nowadays a more dependable and secure network protection principle with a more reliable principle for classifying the faults exists [20]. Some of the ways available today for calculating the distance to fault include:

- steady state algorithms;
- algorithms based on the differential equation of the first or second order written for the power line;
- filter based algorithms;

- algorithms using the method of fuzzy logic, neuronal networks approach and parametric estimation have managed to improve some of the standard function used in the protection of power distribution lines like speed, data processing and evaluation.

For simulating some types of protection systems the standard university tool of MATLAB-SIMULINK with SimPower System-Block Set has been used. Models of a few mentioned types of distance protection algorithms for calculating the distance to fault have been made. In simulations the sensitivity of different distance protection algorithms on harmonics has been investigated and the results of the investigation are discussed in this chapter. The chapter is organized as follows. Section 5.2.1 presents the group of algorithms based on the steady state algorithms, section 5.2.2 the group of algorithms based on differential equations of the first order (DEFO) written for the voltage of the observed power distribution line and section 5.2.3 the group of algorithms based on differential equations of the second order (DESO) written for the voltage of the observed power distribution line. Section 5.2.4 provides the description of two filter-based algorithms. This section also provides a comparison of the results of their implementation on a test network. The theory and implementation of an algorithm based on differential equation and supported with the method of parametric estimation is presented in Section 5.2.5. In Section 5.2.6, the realisation of a technique of harmonic activated neuronal network and its application is presented. Section 5.3 gives some practical results, made on a real protection device in a laboratory, considering the topic of harmonic influence. In Section 5.4 the modelling and testing of a differential protection algorithm is presented. The Conclusion summarizes the testing results of the presented algorithms realised in MATLAB and the practical results made on real protection devices.

5.2 Modelling distance protection in MATLAB.

5.2.1 General information about the investigation

For the modelling of distance protection in MATLAB–SIMULINK, the hardware and software elements of the digital relay are represented by corresponding blocks from the SimPower System-Block Set Library. The number of blocks is set to minimum with the demand of high flexibility of the model and high correspondents to the modelled digital protection. Implemented basic hardware and software components of a digital protection in the MATLAB - library are: ports for data acquisition, digital filters, distance algorithms and a few tripping characteristics. Libraries are made also for current and voltage transformer models. This enables the user to freely design digital relays and network elements by selecting and joining elements from these libraries. This also provides a very good opportunity for the user to learn the different digital protection systems constructions and investigate their behaviour in the different conditions as well as in different configurations of the network [19].

The input signals of the protection terminals are not ideal due to the non-linearities of the integrated power electronics in the system elements. To test the behaviour of the protection system, a simple test–network presented in Fig. 5.1 is used. A wind power generator is connected to the network through a 6-pulse inverter and the load via 12-pulse inverter.

The investigations do not take into account a fault on the distribution line, but injection of harmonics according (5.1) are taken into account.

$$Ck_{\text{order}}(u) = u \cdot p \pm 1, \quad (5.1)$$

$u = 1, 2, 3, \dots, n$

where Ck is the order of harmonics. If $p = 6$, the generated harmonics and their maximum allowed amounts are given in Table 5.1.

From (5.1) it can be calculated that the injected harmonics from a 12-pulse inverter are from the 11th, 13th, 23th, 25th ... order. From Table 5.1 it can be observed that a 12-pulse inverter injects a lower amount of harmonics into the power system.

In order to investigate the behaviour of every algorithm by non-ideal input signals the first tests of the algorithms are carried out for one phase.

Table 5.1: Maximum allowed amount of harmonics by a 6 – pulse inverter according to IEC 61000 – 3 – 2.

Harmonics order	Harmonic current/ Nominal current
5	0,2025
7	0,1025
11	0,08
13	0,06
17	0,05
19	0,05
23	0,03
25	0,03

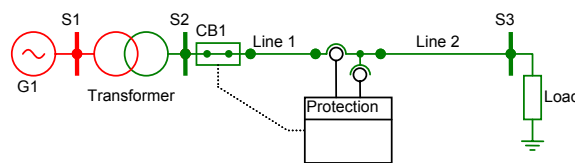

Fig. 5.1: Test-network for protection algorithms

As non-ideal input signals on the protection terminals the maximum values given in Table 5.1 are used. The standard output values of voltage transformer 100V and current transformer 1A are used. The protected line has the following parameters:

- nominal cross section area Al/Fe 95/15 mm²;
- voltage level 10 kV;
- conductor design, wire number x diameter 19 x 2.5;
- conductor diameter 12.5 mm;
- resistance per km $R' = 0.214 \Omega/\text{km}$;
- reactance per km $X' = 0.11 \Omega/\text{km}$;
- line length $L = 20 \text{ km}$.

5.2.2 Steady-state algorithms

To calculate the distance to fault on the protected power distribution line, this group of algorithms uses the steady-state equations of the input signals treating them as solid sinusoidal voltages and currents. With a small sampling rate (8-12 samples per period) of the voltages and the currents, the resistance R (Ohm) and the reactance X (Ohm) is calculated. With the values of the line parameters, the distance to fault can be easily calculated. The algorithms of: Gilbert/Shovlin, Mann/Morrison, Gilcrest/Rockefeller and the T2-Method of Lobos belong to this group [16,18]. The behaviour of all of these algorithms was investigated. As an example, the response of the steady-state algorithms, the algorithm of Gilbert/Shovlin (Fig. 5.2) and the algorithm of Gilcrest/Rockefeller (Fig. 5.3) will be given in the following Section.

The Gilbert/Shovlin algorithm needs three sampling data of voltage and current and calculates the impedance as follows:

$$R = \frac{u_2 \cdot i_2 - 0.5 \cdot (u_3 \cdot i_1 + u_1 \cdot i_3)}{i_2^2 - i_1 \cdot i_3} \quad (5.2)$$

$$X = \frac{u_2 \cdot i_3 - u_3 \cdot i_2}{i_2^2 - i_1 \cdot i_3} \cdot \sin\Delta \quad (5.3)$$

where $\Delta = \omega\Delta t$.



Fig. 5.2: Response of the Gilbert/Shovlin algorithm

The response of this algorithm, when the input signals of voltage and current contain harmonics as given in Table 5.1 is shown on Fig. 5.2.

The Gilcrest/Rockefeller algorithm needs also three sampling data of voltage and current and calculates the impedance as follows:

$$\text{abs}(Z) = \sqrt{\frac{\Delta^2 \cdot (u_3 - u_1)^2 + 4 \cdot (u_3 - 2u_2 + u_1)}{\Delta^2 \cdot (i_3 - i_1)^2 + 4 \cdot (i_3 - 2i_2 + i_1)}} \quad (5.4)$$

$$\varphi = \arctan\left(\frac{u_3 - u_1}{u_3 - 2u_2 + u_1} \cdot \frac{\Delta}{2}\right) - \arctan\left(\frac{i_3 - i_1}{i_3 - 2i_2 + i_1} \cdot \frac{\Delta}{2}\right) \quad (5.5)$$

$$\begin{aligned} R &= \text{abs}(Z) \cdot \cos \varphi \\ X &= \text{abs}(Z) \cdot \sin \varphi \end{aligned} \quad (5.6)$$

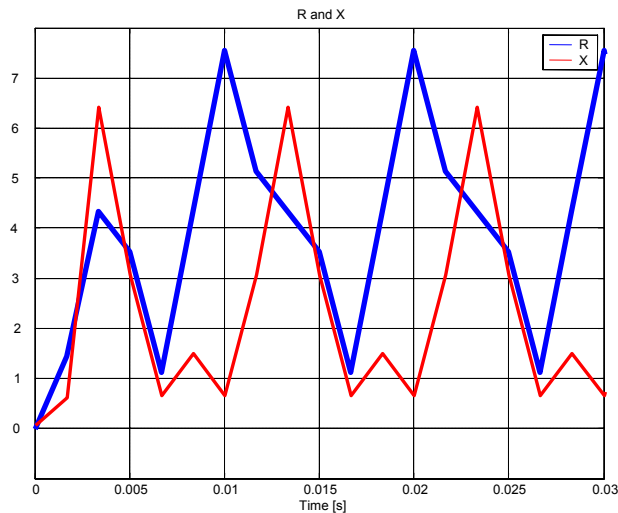

Fig. 5.3: Response of the Gilcrest/Rockefeller algorithm

The results of this group of algorithms are given in Table 5.2.

Table 5.2: Characteristics of the steady-state algorithms

Input signals	Gilbert/ Shovlin	T2-Methode Lobos	Mann/ Morrison	Gilbert/ Rockefeller
Sinusoidal	++	++	+	+
Harmonics	--	--	--	--
Sampling rate	8	8	12	12
Data window (ms)	7.5	5	3.33	5

Symbol meanings: (++) insensitive, (+) relatively insensitive, (0) just acceptable, (-) sensitive, systematic follows [16]

It can be seen, that the algorithms from this group are extremely sensitive to harmonic influence. The estimation of the reactance and the resistance of the power distribution line is not stable and with that the command for relay - tripping is incorrect. The reasons for this lay in the small number of sampling data and the small data window.

These algorithms should not be used for calculation of the fault distance when signal disturbances caused by dispersed energy resources and non-linear loads are present in the network.

5.2.3 Algorithms based on DEFO

In the case of lumped distribution line parameters when the capacitances of the line are neglected the line differential equation for the investigated power distribution line can be written as:

$$u=R \cdot i(t)+L \frac{di(t)}{dt} \quad (5.7)$$

In this way, the transient signals from the network can be taken into consideration. Equation (5.7) is solved with numerical approximation techniques. With a few sampling data (8-24 per cycle) of the input voltages and currents, the line resistance R (Ohm) and Inductance L (H) and consequently the distance to the fault can be calculated. Using this principle as a basis for calculating the distance to the fault on the line, the following algorithms are known in the literature [16]: Ranjabar/Cory, Bornard/Bastide, McInnes/Morrison, and the A3- and A4-Method of Lobos. This group of algorithms has been tested in a test network. The results are given in Fig. 5.4 for the A3- Method of Lobos and characterised as just acceptable.

As a second example, the algorithm of Bornard/Bastide will be shown. This algorithm takes into consideration the capacitances of the faulted line.

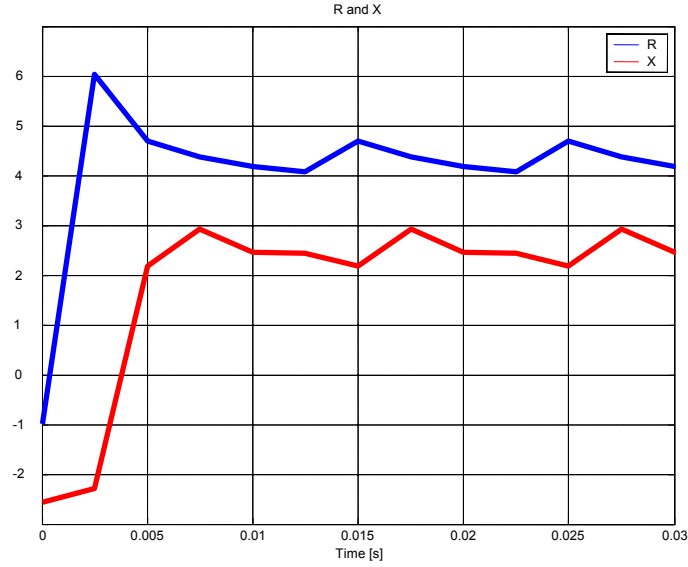

Fig. 5.4: Response of the A3- Method of Lobos

These parameters have been taken into consideration by the value of $e(t)$. With this remark the following equation can be written:

$$u(t) + e(t) = R \cdot i(t) + L \frac{di(t)}{dt} \quad (5.8)$$

The input current is, as in the algorithm of Lobos, written as: $i = I_{\max} \sin(\omega t)$ and with this has been taken as sinusoidal into consideration. Using transformation and approximation techniques, for the parameters of the faulted line can be written:

$$R_0 = \left[\frac{\sum_{j=2}^n i_j \cdot u_j \cdot \left(\sum_{j=2}^n i_{j-1}^2 - \sum_{j=2}^n i_j \cdot i_{j-1} \right) + \sum_{j=2}^n i_{j-1} \cdot u_j \cdot \left(\sum_{j=2}^n i_{j-1}^2 - \sum_{j=2}^n i_j \cdot i_{j-1} \right)}{\left(\sum_{j=2}^n i_j^2 \cdot \sum_{j=2}^n i_{j-1}^2 \right) - \left(\sum_{j=2}^n i_j \cdot i_{j-1} \right)^2} \right] \quad (5.9)$$

$$L_0 = \left[\frac{\sum_{j=2}^n i_j \cdot u_j \cdot \sum_{j=2}^n i_{j-1} \cdot i_j - \sum_{j=2}^n i_{j-1} \cdot u_j \cdot \sum_{j=2}^n i_j^2}{\left(\sum_{j=2}^n i_j^2 \cdot \sum_{j=2}^n i_{j-1}^2 \right) - \left(\sum_{j=2}^n i_j \cdot i_{j-1} \right)^2} \right] \cdot \Delta t \quad (5.10)$$

$$L = L_0 \cdot \frac{\sin(\Delta)}{\Delta} \quad (5.11)$$

$$R = R_0 + L_0 \cdot \tan\left(\frac{\Delta}{2}\right) \cdot \omega \quad (5.12)$$

$$X = \omega \cdot \Delta t \cdot L \quad (5.13)$$

The sampling rate of this algorithm is 24 values per period. The results are given in Fig. 5.5 for the algorithm of Bornard/Bastide and characterised as relatively insensitive on presence of harmonics in the input signals.

The results of this group of algorithms are given in Table 5.3.

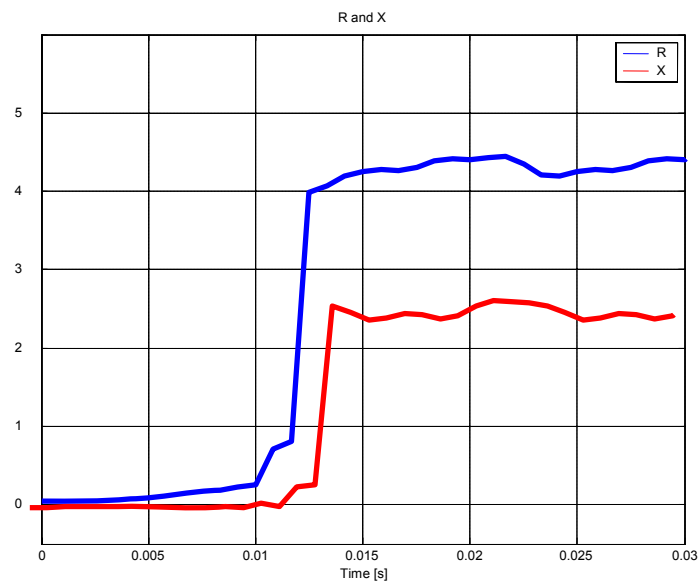

Fig. 5.5: Response of the Bornard Bastide algorithm

Table 5.3: Characteristics of the algorithms solving line differential equation first order

Input signals	A3- Lobos	A4- Lobos	Bornard/ Bastide	McInnes/ Morrison
Sinusoidal	++	++	++	++
Harmonics	0	-	+	0
Sampling rate	8	8	24	20
Data window (ms)	7.5	10	15	11

Symbol meanings: (++) insensitive, (+) relatively insensitive, (0) just acceptable, (-) sensitive, systematic follows [16]

5.2.4 Algorithms based on DESO

This group of algorithms is presented with the algorithm from Smolinski, an algorithm that takes the capacitances of the power distribution line into consideration (π -model of power distribution line). In this way Eq. 5.14 presents the voltage at the measurement terminals of the distance protection.

$$u(t) = R \cdot i(t) + L \frac{di(t)}{dt} - R \cdot C \frac{du(t)}{dt} - L \cdot C \frac{d^2u(t)}{dt^2} \quad (5.14)$$

$$\begin{bmatrix} u_2 \\ u_3 \\ u_4 \\ u_5 \end{bmatrix} = \begin{bmatrix} i_2 & \frac{i_3 - i_1}{2\Delta t} & -\frac{u_3 - u_1}{2\Delta t} & -\frac{u_3 - 2u_2 + u_1}{\Delta t^2} \\ i_3 & \frac{i_4 - i_2}{2\Delta t} & -\frac{u_4 - u_2}{2\Delta t} & -\frac{u_4 - 2u_3 + u_2}{\Delta t^2} \\ i_4 & \frac{i_5 - i_3}{2\Delta t} & -\frac{u_5 - u_3}{2\Delta t} & -\frac{u_5 - 2u_4 + u_3}{\Delta t^2} \\ i_5 & \frac{i_6 - i_4}{2\Delta t} & -\frac{u_6 - u_4}{2\Delta t} & -\frac{u_6 - 2u_5 + u_4}{\Delta t^2} \end{bmatrix} \cdot \begin{bmatrix} R \\ L \\ CR \\ CL \end{bmatrix} \quad (5.15)$$

The results are presented in Fig. 5.6 and characterised as relatively insensitive.

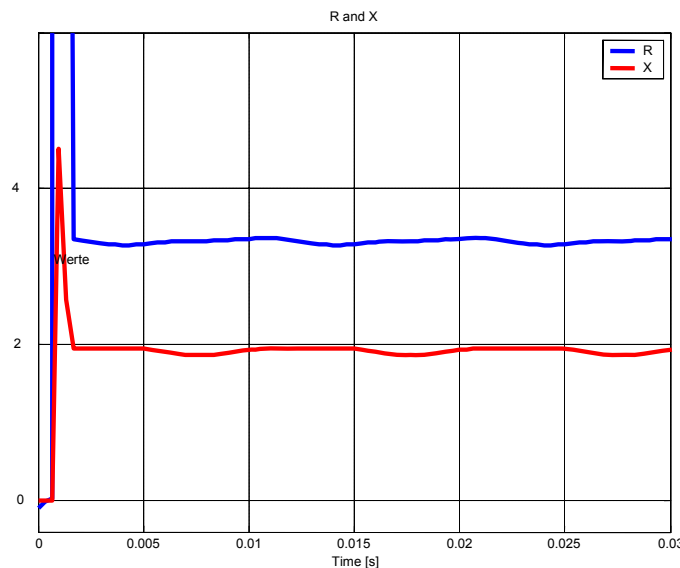

Fig. 5.6 Response of the Smolinski algorithm

In Table 5.4 the result of this algorithm is given. Using solid sinusoidal input signals this algorithm is not stable, because of the linear dependency of the equations system. The implementation of the Smolinski

algorithm as part of a complex algorithm made from a few parallel-connected algorithms is possible.

Table 5.4: Characteristics of the Smolinski algorithm

Input signals	Smolinski
Sinusoidal	--
Harmonics	+
Sampling rate	60
Data window (ms)	2

Symbol meanings: (--) very sensitive, (+) relatively insensitive, systematic follows [16]

5.2.5 Algorithms using filter approach

In this group of methods, the output signals from the measuring voltage and current transformer are filtered, sampled, digitized and sent to the filter algorithm. There are a few known methods of filter algorithms e.g. Phadke/Ibrahim, Slemon/Robertson, Sachdev/Baribeau, Carr/Jackson, the method using the symmetric components, which use different types of filters for calculating the distance to the fault [16]. In this section, the approach of the algorithms of Phadke/Ibrahim [6] and Slemon/Robertson will be briefly presented. These algorithms calculate the orthogonal components of the input signals voltage, given with (5.16) and (5.17):

$$\text{Re}\{U\} = \frac{2}{n} \sum_{k=0}^{n-1} u_k \sin\left(\frac{k \cdot 2\pi}{n}\right) \quad (5.16)$$

$$\text{Im}\{U\} = \frac{2}{n} \sum_{k=0}^{n-1} u_k \cos\left(\frac{k \cdot 2\pi}{n}\right) \quad (5.17)$$

and current (4.18) and (4.19):

$$\text{Re}\{I\} = \frac{2}{n} \sum_{k=0}^{n-1} i_k \sin\left(\frac{k \cdot 2\pi}{n}\right) \quad (5.18)$$

$$\text{Im}\{I\} = \frac{2}{n} \sum_{k=0}^{n-1} i_k \cos\left(\frac{k \cdot 2\pi}{n}\right) \quad (5.19)$$

where n is the number of sampling data for one cycle (in the test example, $n = 20$ (20 samples per signal period $T = 20$ ms) is used).

Using the orthogonal components of the voltages and the currents the resistance R (Ohm) and the reactance X (Ohm) of the power distribution

line can be calculated either directly the algorithm of Phadke/Ibrahim, using Equations (5.20) and (5.21):

$$R = \frac{\text{Re}\{U\} \cdot \text{Re}\{I\} + \text{Im}\{U\} \cdot \text{Im}\{I\}}{(\text{Re}\{I\})^2 + (\text{Im}\{I\})^2} \quad (5.20)$$

$$X = \frac{\text{Im}\{U\} \cdot \text{Re}\{I\} - \text{Re}\{U\} \cdot \text{Im}\{I\}}{(\text{Re}\{I\})^2 + (\text{Im}\{I\})^2} \quad (5.21)$$

Or using the calculation of the impedance and the phase angle as the algorithm of Slemon/Robertson using equations (5.22) and (5.23):

$$\text{abs}\{Z\} = \sqrt{\frac{(\text{Re}\{U\})^2 + (\text{Im}\{U\})^2}{(\text{Re}\{I\})^2 + (\text{Im}\{I\})^2}} \quad (5.22)$$

$$\varphi = \arctan\left(\frac{\text{Im}\{U\}}{\text{Re}\{U\}}\right) - \arctan\left(\frac{\text{Im}\{I\}}{\text{Re}\{I\}}\right) \quad (5.23)$$

$$R = \text{abs}\{Z\} \cdot \cos \varphi \quad (5.24)$$

$$X = \text{abs}\{Z\} \cdot \sin \varphi$$

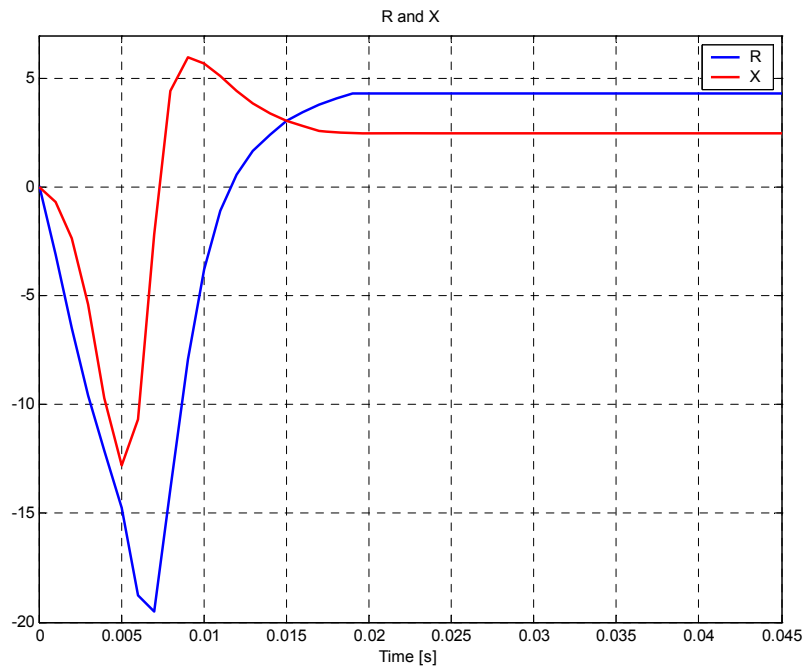

Fig. 5.7a: Response of the Phadke/Ibrahim algorithm

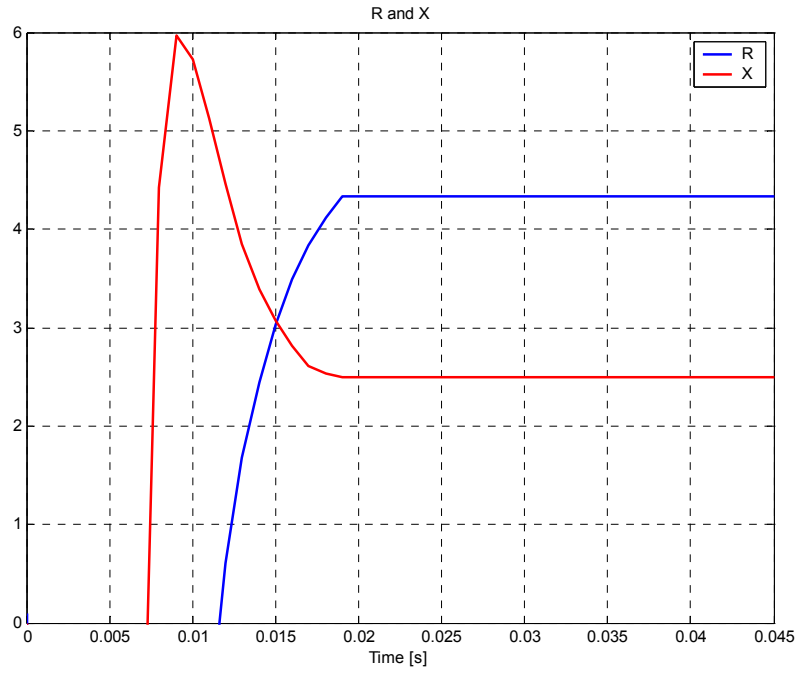

Fig. 5.7b: Response of the Phadke/Ibrahim algorithm

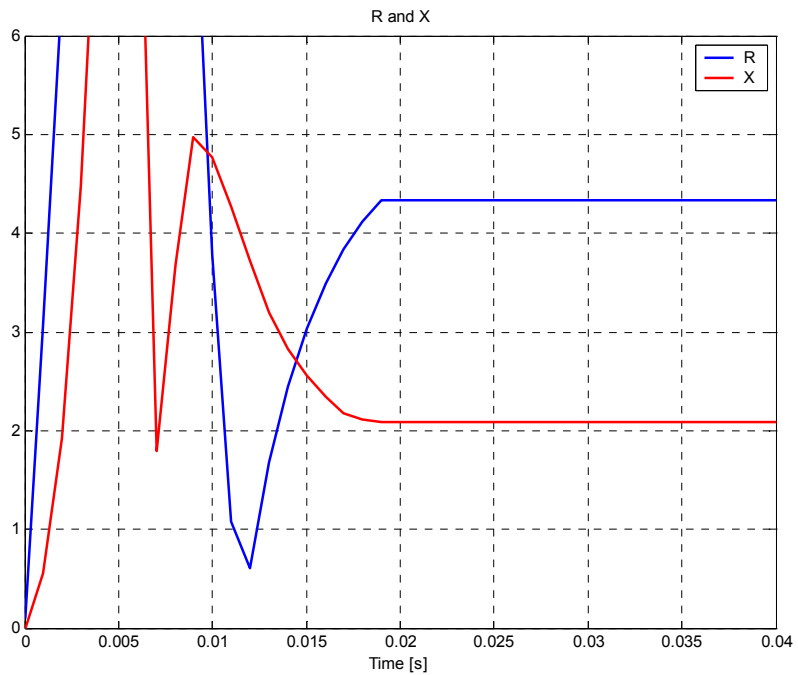

Fig. 5.8: Response of the Slemmon/Robertson Algorithm

It can be noticed that the resistance R and the reactance X of the power distribution line are correctly calculated in a time frame of $t = 20$ ms for the algorithm of Phadke/Ibrahim and in time frame of $t = 28$ ms for the algorithm of Slemmon/Robertson. That is precisely the time frame of one data window for the algorithm of Phadke/Ibrahim [6]. The differences are

due to the method of calculation, realisation of the filter, the sampling rate and the data window. The filter algorithms typically need about 20 ms calculation time, as can be seen in Figs. 5.7a and 5.7b. This time can be shortened by up to 10 ms using different window techniques such as fast Fourier transformation (FFT) or implementations of the least square (LSQ) method, for example [20].

Table 5.5: Characteristics of the filtering-algorithms

Input signals	Phadke/Ibrahim	Slemon/Robertson	Carr/Jackson	Sachdev/Baribeau
Sinusoidal	++	++	++	++
Harmonics	++	++	++	++
Sampling rate	20	20	16	12
Data Window(ms)	20	20	25	15

Symbol meanings: (++) insensitive, systematic follows [16]

As an example, the results of fault at time $t=0.03$ s (Phase B to ground solid fault) are given in Fig. 5.9. It is evident, that the algorithm needs 20 ms to stabilise and calculate the impedance of the three-phase line, as well as after the fault on the line, to calculate the new line parameters [19].

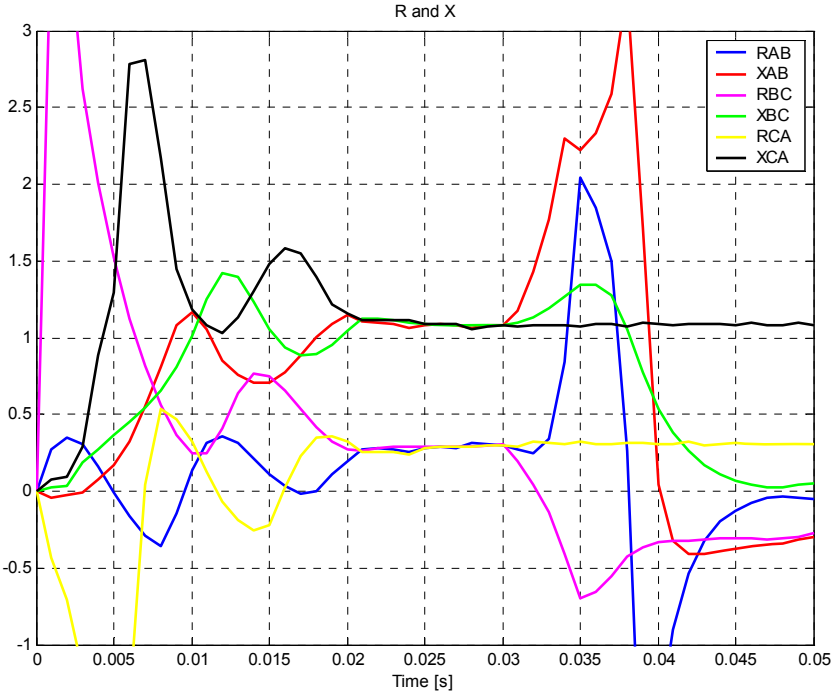

Fig. 5.9: Response of the algorithm Phadke/Ibrahim in the case of phase A to ground fault

The tripping command is given after $t = 20$ ms and the distance to the fault is correctly measured at the first tripping zone of the distance protection algorithm.

These algorithms can be used for calculating the fault distance when a high measurement precision is requested.

5.2.6 Algorithms using parametric estimation

Using the digital values of the input signals it is possible to estimate the distance to the fault [21]. This method is used for the algorithm of differential equation of first order written for the power distribution line [25]. In this case, the voltage on each point of the line is given by Eq. 5.7.

The current in Eq. 5.7 can be written with the help of numerical approximation in Eq. 5.25:

$$i(k) = u(k) \frac{1}{R + \frac{L}{\Delta t}} + \frac{L}{\Delta t} \cdot \frac{1}{R + \frac{L}{\Delta t}} \cdot i(k-1) = a \cdot u(k) + b \cdot i(k-1) \quad (5.25)$$

The coefficients a and b are to be estimated with the presented procedure and include the parameters R and X . With the help of vectors (5.26) and (5.27) the expected estimation error e is evaluated in equation (5.28).

$$\text{phi}(k) = [u(k) \quad i(k-1)] \quad (5.26)$$

$$\theta = [a^* \quad b^*] = \begin{bmatrix} 1 & \frac{L}{\Delta t} \\ R + \frac{L}{\Delta t} & R + \frac{L}{\Delta t} \end{bmatrix} \quad (5.27)$$

$$e(k) = i(k) - \text{phi} \cdot \theta \quad (5.28)$$

$$E_N = I_N - H_N \cdot \theta_N \quad (5.29)$$

Equation (5.27) can be solved with the help of the least square calculation method. The vector I_N comprises the input data of the algorithm and the vector H_N the regression data. In this sense the iteration procedure with LSQ method can be written as follows:

$$\theta(k) = \theta(k-1) + h \cdot e(k) \quad (5.30)$$

and for the next step:

$$\theta(k+1) = \theta(k) + h(k+1) \cdot e(k) \quad (5.31)$$

The error can be minimised with the procedure:

$$e(k) = i(k) - \text{phi} \cdot \theta(k-1) \quad (5.32)$$

The results of the calculation using this algorithm are presented in Fig. 5.10. It can be noted that this method accelerates the calculation of the impedance in a factor of 6, namely the results of the swinging starting up with this method are managed in timeframe of $t = 3$ ms. The reasons for this lay in the LSQ method of calculation. In this method, an acceleration procedure is also implemented.

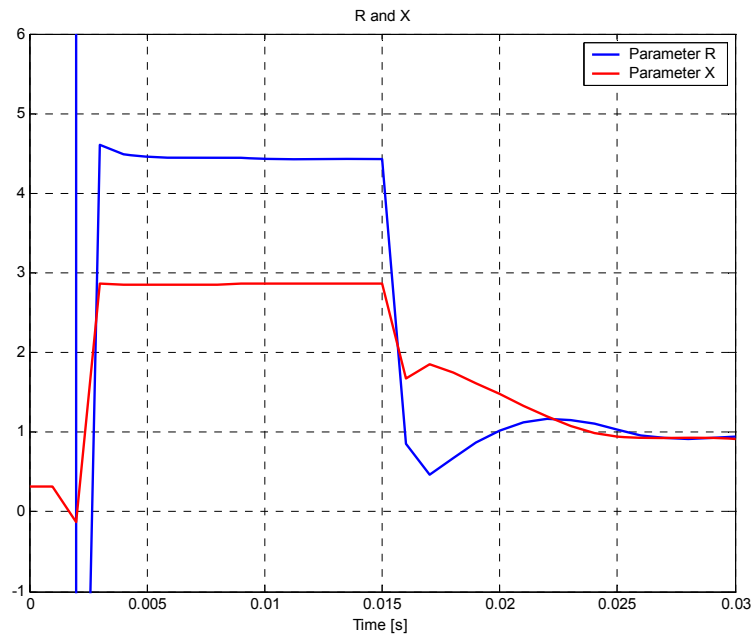

Fig. 5.10: Response of the algorithm using Parametric Estimation in the case of phase A to ground fault

The acceleration procedure is given as:

$$h(k+1) = P(k) \cdot \text{phi}(k+1) \cdot \frac{1}{[\lambda + \text{phi}^T(k+1) \cdot P(k) \cdot \text{phi}(k+1)]} \quad (5.33)$$

$$P(k+1) = \frac{1}{\lambda} P(k) - \frac{1}{\lambda} h(k+1) \cdot \text{phi}^T(k+1) \cdot P(k) \quad (5.34)$$

The factor $1 > \lambda > 0.9$ is the so-called forgetting factor. The forgetting factor enables that oldest data which have less influence on the calculation to be neglected and to the new data importance is given by using different weights. This method is faster than the filtering algorithms method.

5.2.7 Algorithms using HANN

The idea of using neuronal networks in protective relaying is not new. Various applications of neuronal networks were used in the past to improve some standard functions used in the protection of power distribution lines like e.g. speed, signal processing, data evaluation [17,24]. The neuronal networks have been related to fault type and direction classification [17,22]. In the following section, a kind of harmonic activated neuronal network (HANN) is going to be presented. A comparison between the two different approaches of training the neuronal networks namely, LSQ (least square) and back propagation (BP), will be presented. This type of neuronal network has been used for fault type classification. The idea of realisation of a HANN began due to the possibility that every non-sinusoidal signal can be written as a Fourier array of sinusoidal functions [23]. This function can be divided into four parts as follows:

$$y(\varphi) = \frac{a_0}{2} + \sum_{k=1}^N a_k \cdot \cos(k\varphi) + \sum_{k=1}^N b_k \cdot \sin(k\varphi) + d(\varphi) \quad (5.35)$$

The first part includes the constant component, the second and third parts the sinusoidal functions and the last part the approximation error. This function can be approximated, trained (learned) and reproduced with the help of HANN (Eq. 5.36).

$$y'(\varphi) = \sum_{k=0}^K \theta'_{Ak} \cdot A_{Ak}(\varphi) + \sum_{k=0}^K \theta'_{Bk} \cdot A_{Bk}(\varphi) = \theta'^T_A \cdot A_A(\varphi) + \theta'^T_B \cdot A_B(\varphi) \quad (5.36)$$

where:

$$A_A^T(\varphi) = [1 \quad \cos(\varphi) \quad \cos(2\varphi) \quad \dots \quad \cos(k\varphi)]^T \quad (5.37)$$

$$A_B^T(\varphi) = [\sin(\varphi) \quad \sin(2\varphi) \quad \dots \quad \sin(k\varphi)]^T \quad (5.38)$$

$$\theta_A^T = [\theta_{A0}^T \quad \theta_{A1}^T \quad \theta_{A2}^T \quad \dots \quad \theta_{Ak}^T]^T \quad (5.39)$$

$$\theta_B^T = [\theta_{B0}^T \quad \theta_{B1}^T \quad \theta_{B2}^T \quad \dots \quad \theta_{BK}^T]^T \quad (5.40)$$

With this the parameter error can be written:

$$\Phi_A = \theta_A^{T^*} - \theta_A^T \quad \text{and} \quad \Phi_B = \theta_B^{T^*} - \theta_B^T \quad \text{and for the training error:}$$

$$\begin{aligned} e(\varphi) &= y'(\varphi) - y(\varphi) = \theta_A^{T^*} \cdot A_A(\varphi) + \theta_B^{T^*} \cdot A_B(\varphi) - \theta_A^T \cdot A_A(\varphi) - \theta_B^T \cdot A_B(\varphi) = \\ &= \Phi_A^T \cdot A_A(\varphi) + \Phi_B^T \cdot A_B(\varphi) \end{aligned} \quad (5.41)$$

The training gives a result about the spectral analysis of the identification of the input signals, with which the process can be diagnosed and monitored. The training data can be obtained from measurements or computation of different fault scenarios in the networks. For evaluation of the procedure, the amplitude and the phase of the components of the input signals can be given as follows:

$$A'_K = \sqrt{\theta_{AK}^2 + \theta_{BK}^2} \quad (5.42)$$

and

$$\psi'_K = \arctan \frac{\theta_{BK}}{\theta_{AK}} \quad (5.43)$$

The training law can be written as in Eq. 5.44 and 5.45:

$$\frac{d}{dt} \theta'_A = -\eta \cdot e \cdot A_A(\varphi) \quad (5.44)$$

and

$$\frac{d}{dt} \theta'_B = -\eta \cdot e \cdot A_B(\varphi), \quad (5.45)$$

where the coefficient η represents the training increment. The calculation of the distance to the fault is realised with the help of an additional Fourier filter algorithm.

Least Square Method – LSQ Method

This training method is used to bring the square difference between the sampled signal and the components of the calculated signal to a minimum in iteration steps $M < n$ (Eq. 5.46).

$$e^2 = \frac{1}{M} \sum_{n=0}^{M-1} (f(nt_a) - (A_A \cos(n\omega_n t_a) + A_B \sin(n\omega_n t_a)))^2 \Rightarrow \text{Minimum} \quad (5.46)$$

This will be reached as soon as equation (5.47) has been achieved:

$$\frac{\partial e^2}{\partial A_A} = \frac{\partial e^2}{\partial A_B} = 0 \quad (5.47)$$

For $M < n$, the results give the approximated values for the Fourier coefficients and for $M = n$, the Fourier coefficients.

Back Propagation Method

This method is based on the following equations (5.48 – 5.51):

$$E = \frac{1}{2} (y[k] - \theta'^T A[k])^2, \quad (5.48)$$

where $\theta'^T A[k]$ is calculated from HANN.

The differential of the error is given by (5.49):

$$\frac{\partial E}{\partial \theta'} = (y[k] - \theta'^T A[k]) \cdot (-A[k]) = -e[k] \cdot A[k], \quad (5.49)$$

$$\text{where } y[k] - \theta'^T A[k] = e[k] \quad (5.50)$$

presents the error by the calculation and $\frac{\partial \theta'}{\partial t} = -\eta \cdot e \cdot A$

The training law with gradation principle can be written as:

$$\theta'[k] = \theta'[k-1] - \eta \cdot e[k] \cdot A[k] \quad (5.51)$$

where η is the training step.

This method is graphically presented in Fig. 5.11.

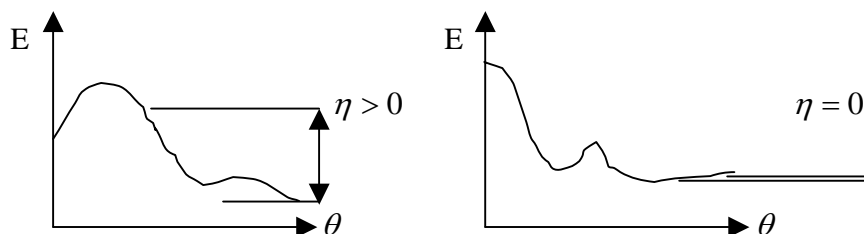

Fig. 5.11: Definition of using different training steps

As it can be seen from the Fig. 5.11, that the value of the training step is very important in this method. It means that when η is changeable during

the time of the training the HANN learn faster. The comparison results of the two-presented methods are given in Fig. 5.12 and Fig. 5.13.

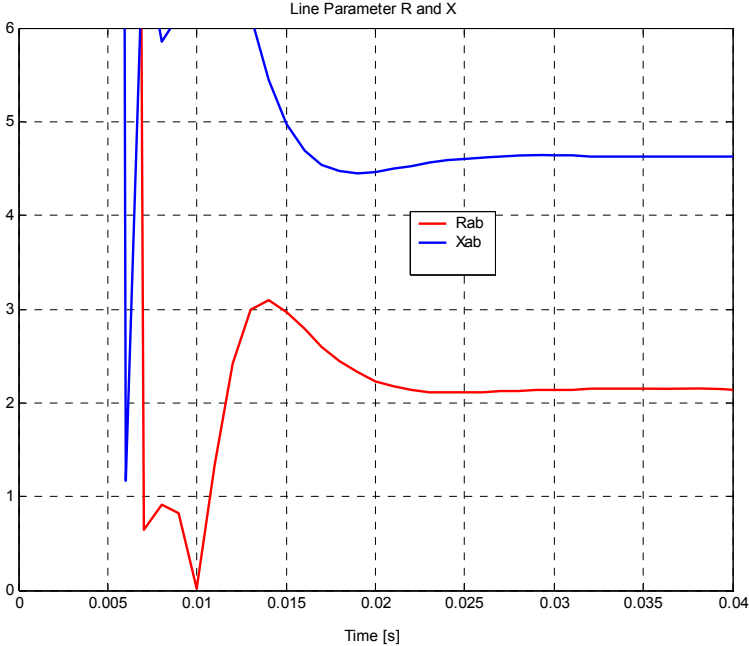

Fig. 5.12: Response of the algorithm of HANN learned with LSQ method in the case of phase A to ground fault

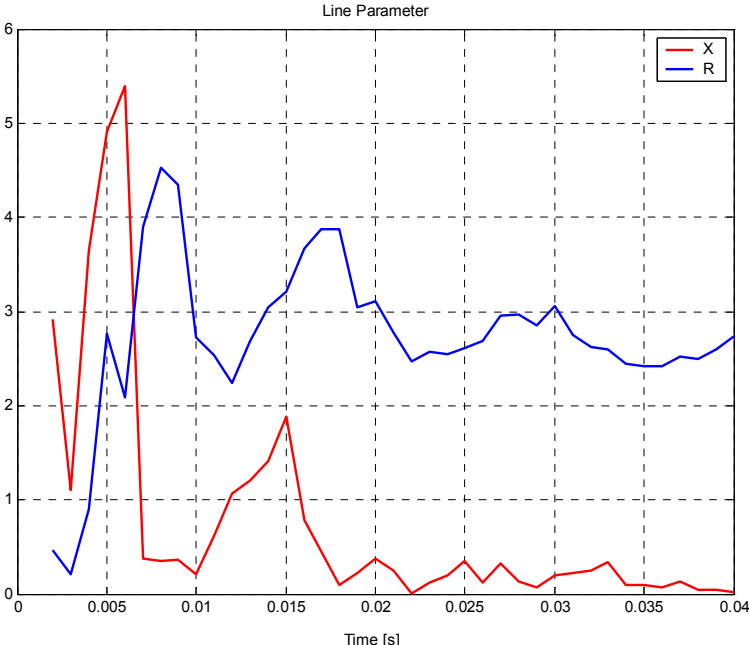
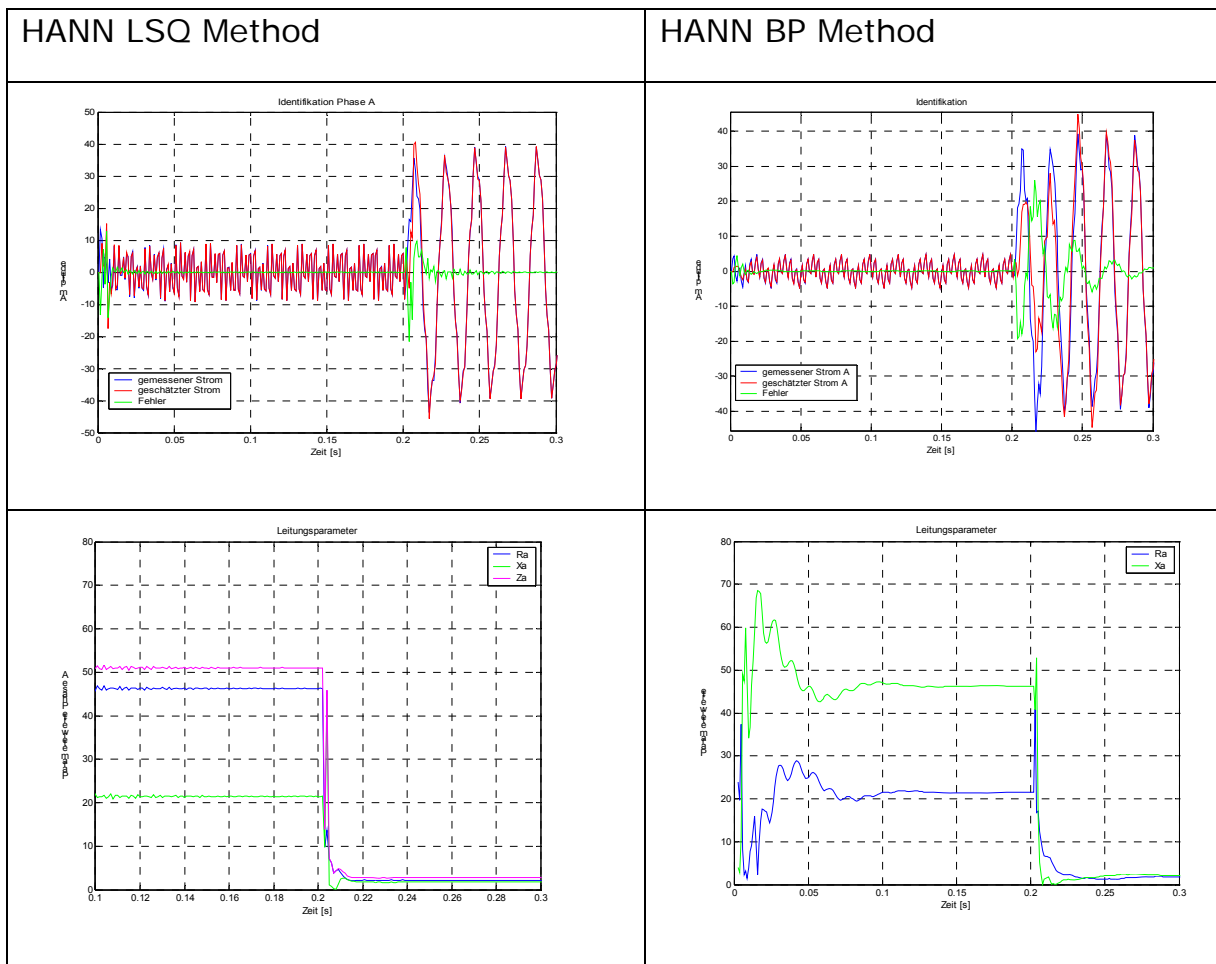

Fig. 5.13: Response of the algorithm of HANN learned with BP method in the case of phase A to ground fault

In the network with protecting device with HANN algorithm that is trained using the LSQ method a phase to ground fault at $t = 12 \text{ ms}$ has been simulated. In Fig. 5.12 it can be seen that this algorithm needs $t = 5 \text{ ms}$ to stabilize and $t = 12 \text{ ms}$ to calculate the fault. The second calculation approach HANN trained with BP needs over $t = 20 \text{ ms}$ to stabilize and has been tested with the same fault type, giving the result after $t = 12 \text{ ms}$. As it can be seen in Fig. 5.12 and Fig. 5.13 the method of LSQ gives the results of the calculated parameters much faster than the method of BP. The reasons for this lay in the method of calculation. The swinging of the signals has been successfully eliminated with the method of LSQ.

Programmed in three phases the difference between the two methods of calculation using HANN is also evident, as shown on the next figures:



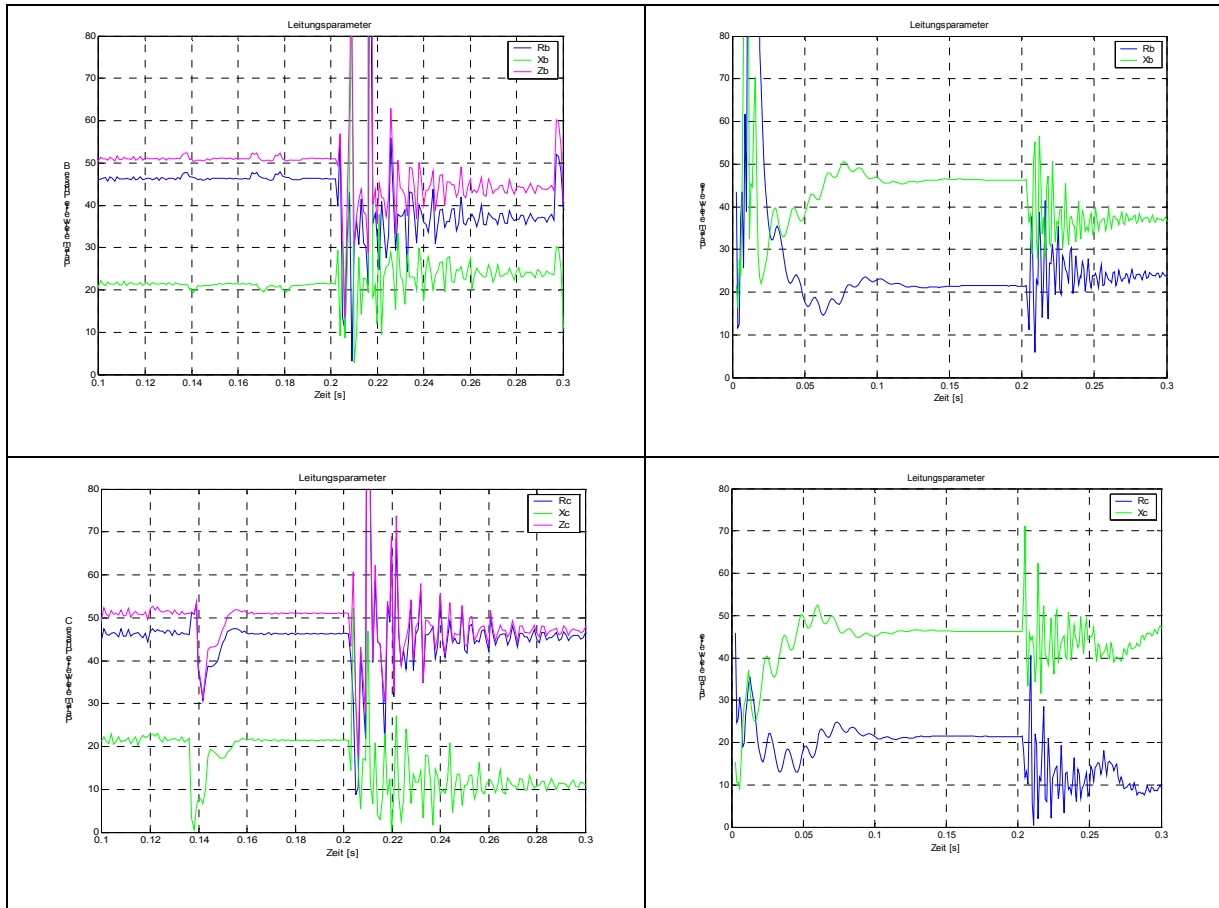

Fig. 5.14: Comparison of HANN BP and HANN LSO

The components of the short circuit current, i.e. the harmonic coefficients of the input signals, calculated with HANN are presented in Fig. 5.15.

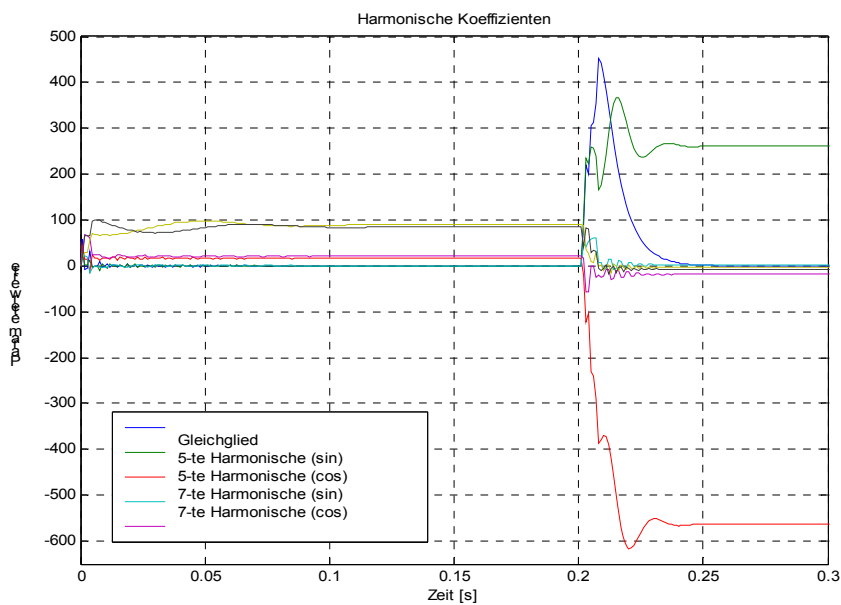

Fig. 5.15: Components of the short circuit current

The neuronal networks implemented with the aim of protecting a line are much faster than the conventional methods of line protection. However, these systems are able to produce good results only for those situations that have been explicitly considered during their design and training.

5.3 Practical analyses of digital protection devices

The results from the simulations have also been compared with the results from the practical measurements in the Institute’s laboratory. A simulation that works without any feedback/interaction coming from the protective systems or dynamic switching action is an Open Loop Simulation. A Real Time Digital Simulator (RTDS) allows the simulator to process real time data coming from the relay being tested and with this allow closed loop testing so that the relay response can modify simulation behaviour in real time [26, 87].

In the laboratory at the university an open loop of tests have been made. Different amounts of harmonics, a multiple of the standards IEC 61000 - 3 - 2 have been sent to the digital distance protection device (Table 5.6) using an OMICRON device. The tested protection contained an algorithm based on the DEFO with integrated filter. It has been searched for the point of tripping, when the signals contain a high amount of harmonics but do not represent a fault signal. The first results show the response of the protection when the input signals from current and voltage contain as many harmonics as the standard allows. The tripping follows when the amount of harmonics in the signals reaches the value of 4 times the standard (5th line in the Table 5.6). In this case the tested distance protection of the lines L1 and L2 (Phase A and Phase B) picked up and sent a tripping command to the circuit breaker. The signals that lead to false tripping are illustrated in the Figure 4.15.

Table 5.6: The European Norms EN 61000-3-2

Norm (N)	Harmonic order / [%] share							
	5	7	11	13	17	19	23	25
6-p	4,2	3,5	2,4	2,1	1,4	1	1	1
12-p	-	-	2,4	2,1	-	5	1	1
N * 2	8,4	7	4,9	4,2	2,8	2,1	2,1	2,1
N * 3	12,6	10,5	7,4	6,3	4,2	3,1	3,1	3,1
N * 4	16,8	14	9,8	8,4	5,6	4,2	4,2	4,2

Comparing the results from the simulations and the practical testing, it can be concluded that a high amount of harmonics in the network influences the proper working conditions of the digital protection device.

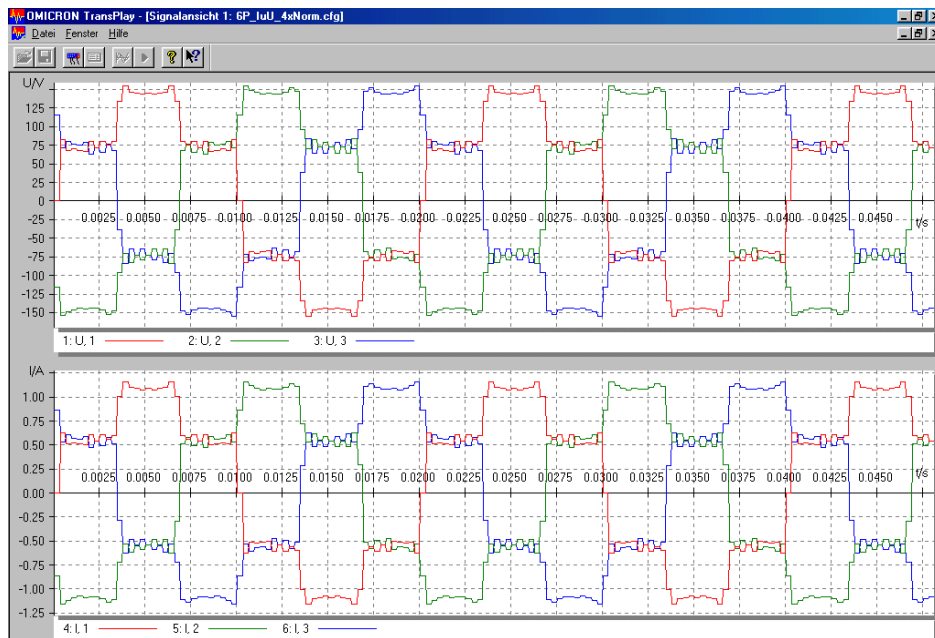

Fig. 5.16: Voltage and current curves that lead to false trip command

When the input signals of voltage and current contain four times more than the allowed harmonics, then a false trip command will be sent from the tested distance protection device to the circuit breaker. As it can be seen from Fig. 5.16 such signals are very unlikely in the power system [17]. The tripping time of the digital distance protection device in the practical analysis was less than 30 ms.

Conclusions

The start-up as well as the behaviour under fault conditions of the classical algorithms using a differential equation of first order, orthogonal filters, and the new methods using the technique of parametric estimation and harmonic activated neuronal networks were presented. A comparison has been made concerning the criteria of speed and selectivity. The method of parametric estimation implemented on an algorithm that is based on a differential equation of the first order, as well as the method using the harmonic activated networks, implemented on a filter algorithm offers a possibility to accelerate the calculation of the distance to fault by

the algorithms, the swinging period of the start up of the algorithms has been successfully eliminated with the LSQ method. The practical analyses show that when the input signals of voltage and current contain four times more than the allowed harmonics then a false trip command will be sent from the tested distance protection device to the circuit breaker.

5.4 Modelling of differential protection devices

In special situations e.g. important industrial customers, a power distribution line can also be protected using a line differential protection. The currents of both sides of the distribution line are used as input signals to the protection relay. The realised algorithm functions under the well-known current differential method. In case of a fault in the protected zone, the protection should send a trip command to the circuit breaker and in the case of a fault outside the protected zone no command will be sent. Especially in systems with high short circuit power and a fault close to the relay but outside the protected zone, the effect of current transformer saturation becomes important [7]. This effect represents the difference in the shape between the input and the output current of the current transformer. The higher the difference, the smaller the measurement precision of the current transformers, and with that the higher the measuring error and the possibility of a false tripping command [10,11]. For this purpose models of different current transformers considering the parameter time-to-saturate are programmed and tested.

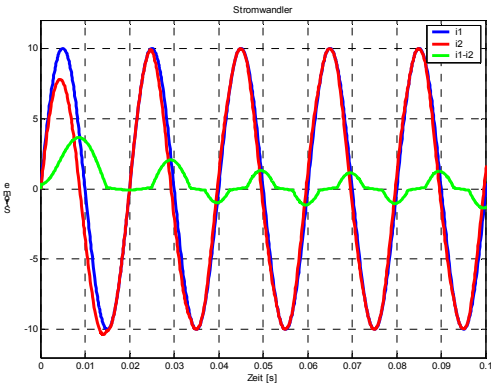

Fig. 5.17: Low - Saturation characteristic

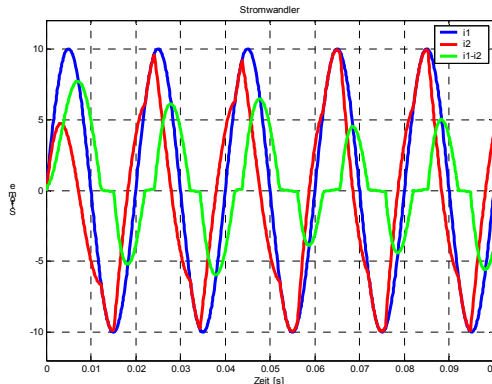

Fig. 5.18: High - Saturation characteristic

In Fig. 5.17 and Fig. 5.18 two examples as a result of different ferromagnetic - material characteristics and with different magnetisation curves and saturation effects are presented. Comparing the two given characteristics (Fig. 5.17 and Fig. 5.18) the importance of this event should be clear. This problem can also occur in the over-current protection [9,12].

6. Protection systems in networks with DER

6.1 Introduction. Impacts of power supply systems and challenges of protection systems

The future development of power systems depends on the growing demand for energy which strongly differs in different countries. Based on a typical life cycle of a system the important stages in the system development are given in Fig. 6.1. The problems connected with the limitations of existing energy resources, as opposed to a continuously growing world population, especially in developing and emerging countries, play and will play even more in the future an important role [31]. Environmental matters, along with public acceptance of certain technologies which also have a strong political aspect, will likewise become increasingly significant factors, also in this region of the world.

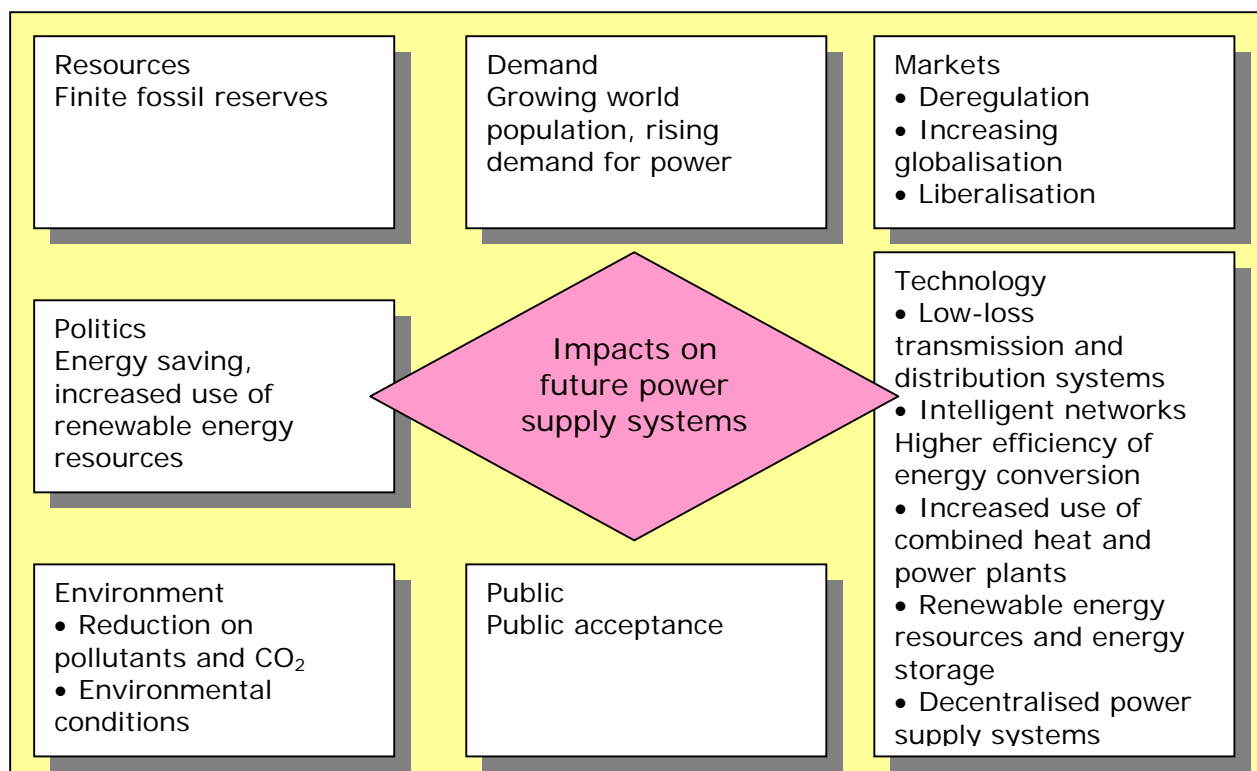

Fig. 6.1: Impacts on future power supply systems

The global trends of deregulation, globalisation and privatisation have had and still have a strong impact on the electric power industry. The deregulation or the liberalisation has the aim of providing cheaper electric energy by opening the markets. The opening of the markets and the national borders support the global economy. In most of the west European countries no home markets exist any more. Due to this fact, more and more companies are forced to act as and be a "Global Player". The privatisation has the aim of obtaining, the best value of financial capital needed for providing infrastructure in the energy market, from private investors [31]. In this sense, the structure of the power system is changing in technical and in organisation fields. The continuously improved products and development of innovative technologies support these changes. The power system develops in the direction of:

- extension of interconnected systems;
- increased power exchange among interconnected systems;
- transmission of large power blocks over long distances (water power resources, wind energy, solar energy);
- decentralised power generation.

Due to the liberalisation of the energy markets and as well as the implementation of DER in the network, the network structure has changed from centralised to decentralised. These changes are illustrated in Fig. 6.2. The hierarchical line of power generation by the big coal and nuclear power plants, the energy transmission on long power lines and finally, the distribution of the energy to its users is changing in the new decentralised energy environment. With these network changes, the direction of power flow, which was clearly defined before, now changes according to the ratio of energy offered from DER and the power system on the higher voltage level and the energy demand from the network customers. The distribution line becomes in this sense a bi-directional power link. The protection systems installed in the medium voltage distribution power system, are often not set to manage these variable changes of direction of power flow. With these short analyses the need for new protection concepts for each system is clear. Compared with the energy generation from nuclear plants, gas or coal, decentralised energy generation usually doesn't depend on the energy demand in a given area, but mostly on the

intermittent weather conditions in that area e.g. the presence of sun, water, wind.

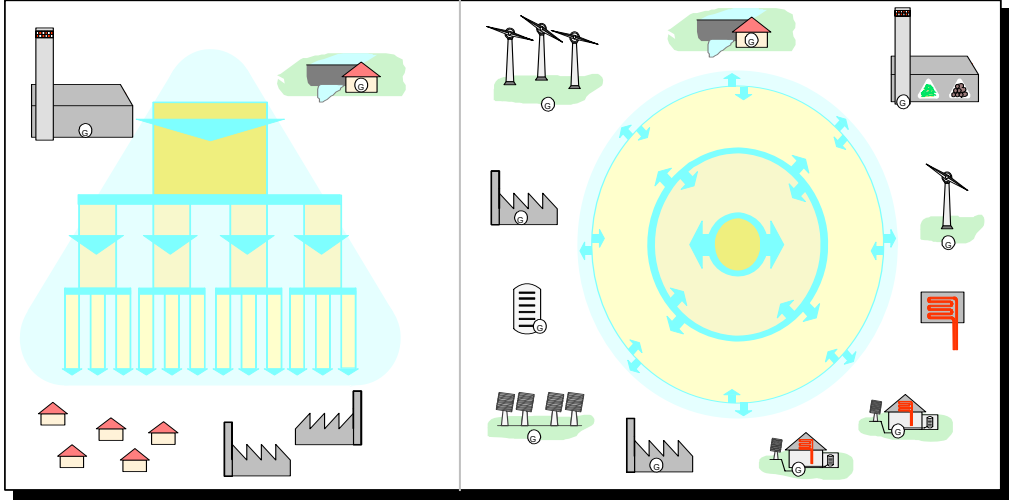

Fig. 6.2: Network structure before and after the liberalisation of the energy market (decentralisation of energy generation)

With the implementation of DER on the network, the voltage stability improves and the loss of active power, mostly on the long transmission lines, is reduced, since the energy is generated close to the energy demand. But, the implementation of DER on the middle voltage level also brings with it the following problems that need to be solved: third party access in the power transmission, overload during low generation capacity of the embedded generators, dynamic stability after a fault occurrence, decoupling, ability to function as an island, load rejection and voltage control [40]. The whole system might characterise itself as a swinging system in the presence of fault, because of the non-presence of “powerful” generators that can create a strong network. Such a network is also characterised by a very low short circuit power, which is definitely going to affect the protection system [41].

The network protection is usually realised with over-current (inverse, very inverse, with/without time gradation) on the medium voltage level and with fuses on the low voltage level. Realised in this way, the network protection is fulfilling the demands of selectivity, sensitivity and speed in the hierarchical network [42].

The protection devices implemented in the network are about to be set to match these changes. The concepts of protection devices before and after the implementation of DER will be shown in this chapter in a few examples of two MV networks [43].

This chapter, in Section 6.2 gives the results of the simulations in two distribution test networks (with and without DER implementation). Later, the possible problems with the network protection concepts as well as solutions will be listed. In Section 6.3 the possibility of using the current direction criteria is illustrated, in Section 6.4 the possibility of using the communication technology and in Section 6.5 the idea of using signal injection for network protection purposes.

6.2 Investigations in test networks

6.2.1 Test networks

A) Network I – 10 kV Network

Network I, given in Fig. 6.3, is supplied from from the power system. The power delivery from the system to the network is realised with two cables with length app. 1 km. The network consists of eleven nodes and the nodes are connected by twelve cables. Each cable length is about 400 m, which makes representative in a network of a small part of a city. The users are connected to the network via 10/0.4 kV-transformers. The transformers are loaded low (25-40%) of nominal load. The network contains one ring, but can also be operated as a radial network by opening the circuit breaker, see Fig. 6.3.

B) Network II – 20 kV Network

Network II given in Fig. 6.4 is also supplied from the power system. The energy delivery is realised via two 110/20 kV transformers. The network contains around 45 loads which are connected to each other by 30 cables. The cables are much longer ($l > 1$ km) than those in network I. This network is intended to represent a small dispersed town or village network. The users are connected to the network via 20/0.4 kV transformers. The transformers are heavily loaded 70-80% of the nominal load. The network also contains loads which are directly connected to the network on a 20 kV voltage level. The network may contain a few rings, or

can also be operated as a radial network by opening the circuit breakers, see Fig. 6.4.

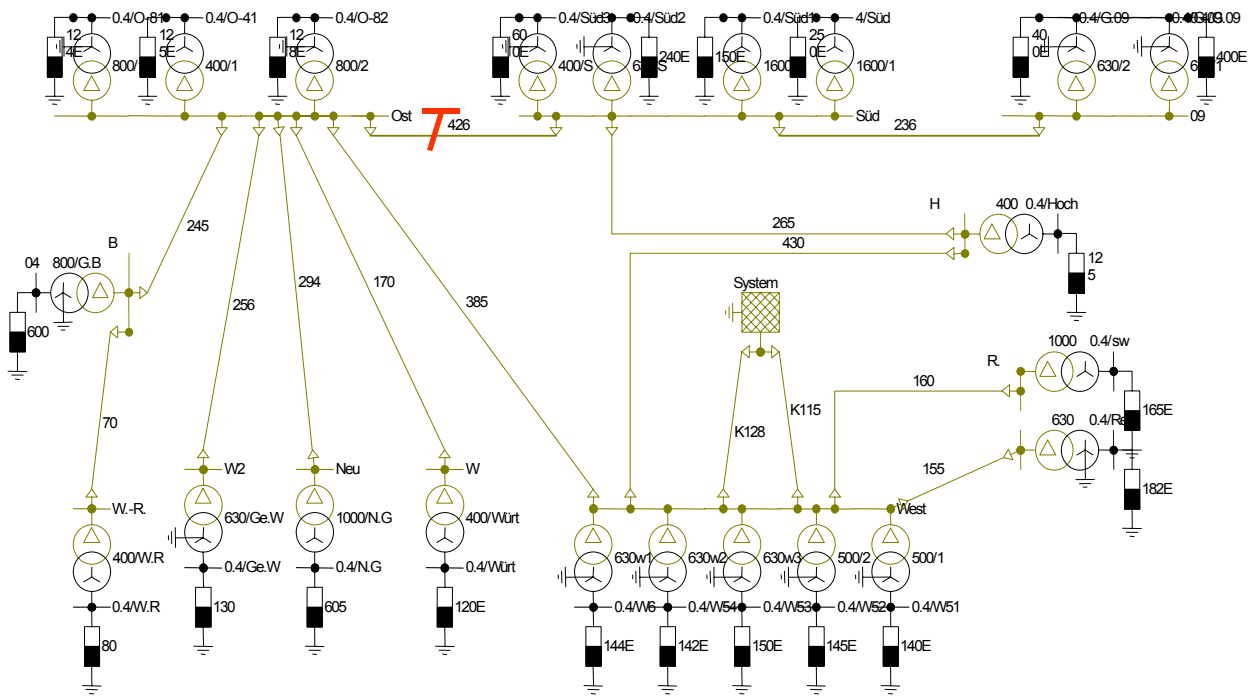

Fig. 6.3: Network I - 10 kV Network

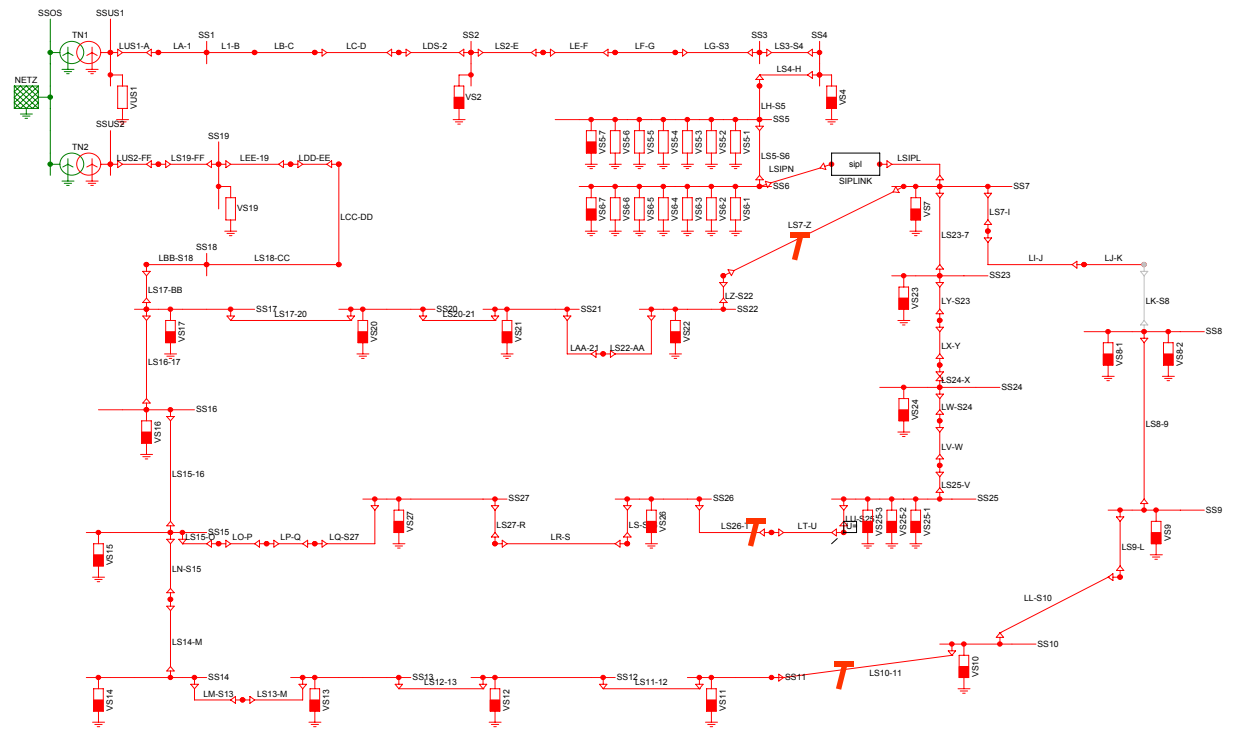

Fig. 6.4: Network II - 20 kV Network

6.2.2 Network scenarios and discussion

In the previous Section two networks have been presented. Network I is a part of a small city network and network II is a network of a small dispersed town or village. These distribution networks have different characteristics, line lengths, different transformer loads and have been chosen for this investigation concerning connection of DER into the power system, because they present typical examples from the practise.

In the presented networks the following scenarios in terms of the implemented network protection are discussed:

Scenario A: Networks with conventional resources (without DER),

Case a) the network is operated radially,

Case b) meshed networks.

Scenario B: The DER contribute to the main power supply from 10-90%,

Scenario C: The DER substitutes the main power supply.

Network I, Scenario Aa

The circuit breakers on the line presented in Fig. 6.3 are open and the network is operated radially. The realisation of the network protection is presented in Fig. 6.5. In radial networks, the selectivity of network protection is realised using simple over-current protection. The fault current level describes the effect of faults in terms of current or power. It gives an indication of the short circuit current or (apparent) power boost. The fault level in p.u. is defined as:

$$I = \frac{1}{z_{th}} \quad (6.1)$$

where I is the fault current related to the nominal current and z_{th} is the inner impedance of the Thevenin representation of the network in p.u. Typical fault levels in distribution networks are in a range of 10-15 p.u., where 1 p.u. corresponds to the rated current [97]. This is, phase-phase or phase-earth faults normally result in an overcurrent which is significantly higher than the operational or nominal current. The amplitude

In case of a fault on a line in this network, the main part of the fault current comes from the main power supply. As a result, the short circuit capacity of the network and the amplitude and the duration of the fault current are also set from the main power supply. Their values hardly vary from the values obtained in scenario Aa and Ab. Therefore, it is not necessary to change any settings of any of the protection devices in the network.

Network 1, Scenario C

When a network is separated from the main power supply and thereby creates an island, the network protection concept must be changed (Fig. 6.9). The network contains multiple power suppliers, but has no longer the main power supply. The implemented network protection was selected and set when the main power supply was present in the network. As discussed previously, in case of a fault on a line or a node in the network, but only in the cases when the main power supply is present in the network, the short circuit power of the network as well as the amplitude and the duration of the fault current are set from the main power supply. To fulfill the protection criteria, there has to be a powerful source providing a high fault current until the relays trigger.

In the case of an island the amplitude and the duration of the fault current is dependent on the DER in the network. The DER are connected to the network via a power electronic inverter. The inverters are often equipped with controllers that prevent high currents. It could happen that there is almost no significant rise of the phase current and the fault is therefore not detected from the overcurrent protection system. The other problem are the dangerous touch voltages that may occur even if the current is low. Furthermore permanent faults may spread out and destroy more equipment [97].

So the injected short circuit current from DER I_k is either $I_k = 1.1 I_n$, or the current is limited to value $I_k = 0$. The duration of the short circuit current is limited by this element to the maximum value of 10 to 15 ms. This phenomena characterises the speciality of this scenario. With this, a new problem in the network protection is introduced. Namely, the amplitude of the short circuit current, as well as the duration of the short

circuit current are not able to reach the afore-mentioned settings of the protection devices in the network. Under this circumstance no tripping command will be sent to any of the protection devices, and the network will continue to operate under unallowed fault conditions. There are a few solutions to this problem of lack of network protection. A first possibility is the implementation of a new protection concept, namely the differential protection on each line in the network. This solution is very expensive, because of the need for a new type of protection device and pilot wires for each line for the communication between two devices protecting the same line. The other possible solution is using the same protection principle as presented in the past scenarios, graded over-current protection with direction, but in addition, this protection concept take into account the implementation of communication channels. The communication channels are seen only between the neighbouring substations. With this idea the protection devices implemented in each substation have the possibility to communicate and exchange data with the other protection devices implemented on the neighbouring substation in normal as well as in fault conditions.

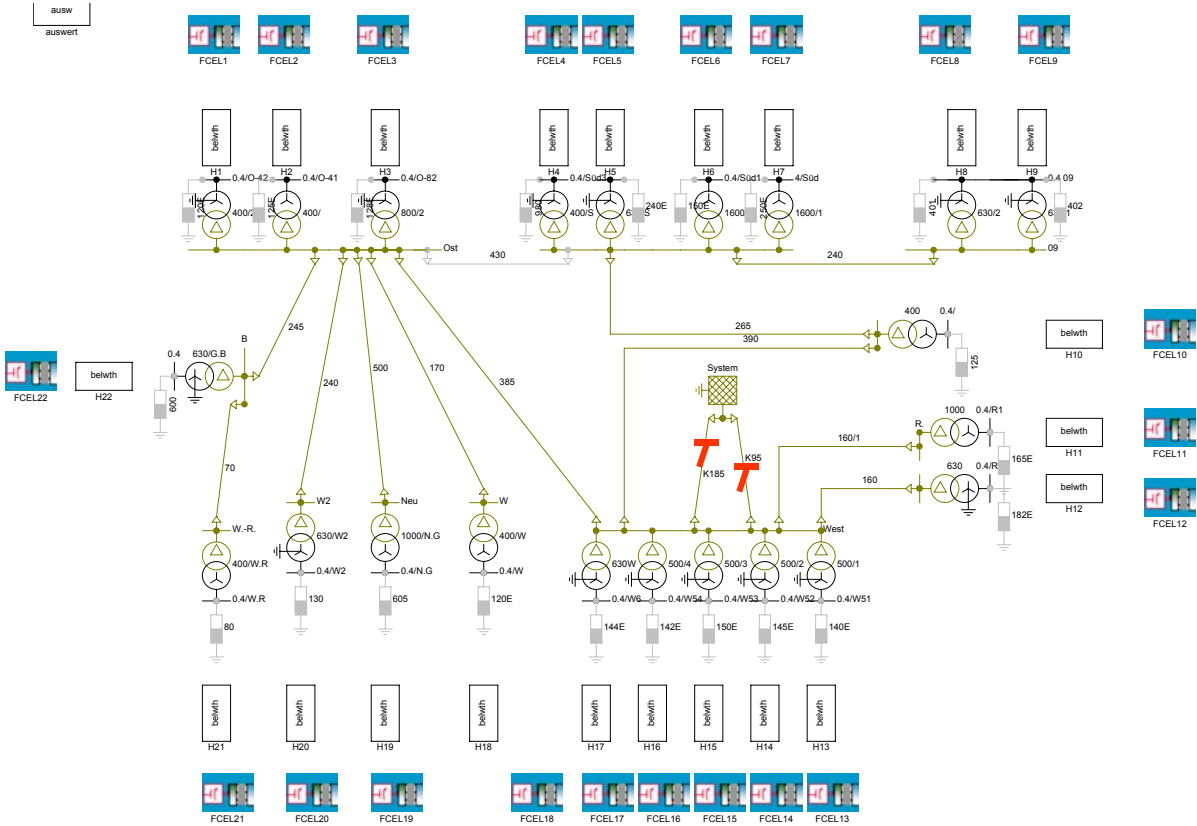

Fig. 6.9: Separation of the main power supply on network 1, Scenario C

Network II, Scenario Aa

The protection concept of the second example network presented in Fig. 6.10 is very similar to the protection concept of the first example network. With regards to investment costs, the protection concept can also be realised only with graded over-current protection. When the circuit breakers as presented in Fig. 6.4 are opened, the network contains no rings and is operated radially. The settings of the protection devices is presented in Fig. 6.10. The problem that occurs here is that, when the same procedure of time grading as in example network 1 is used, is that the tripping time of the breakers close to the supply station will need approximately 2.4 s. This time is too long for of a short circuit current at the secondary side of the supply transformers, because of their thermal insulation. The two options in this case are either smaller grading times of 200 ms (instead of 300-400 ms), or global tripping, where the selectivity of the protection system decreases.

Network II, Scenario Ab

The idea of protecting this network is similar to the protection concept for network I in scenario Ab. The circuit breakers on the line presented in Fig. 6.4 are closed and the network is operated as meshed with a few rings. Changes according to the coordination of the network protection, are needed for the protection devices that are set to protect the cables that are involved in the rings. All of these protection devices need to have a over-current criteria which include direction. In this way these protection devices are able to "see" the direction from which the fault current is coming, so that they can assure a selective tripping and with that offer to the customers a reliable and secure power supply. The other protection devices already present in the network do not suffer any changes of their settings, because the changes of the value of the currents flowing through the cables they protect are negligible.

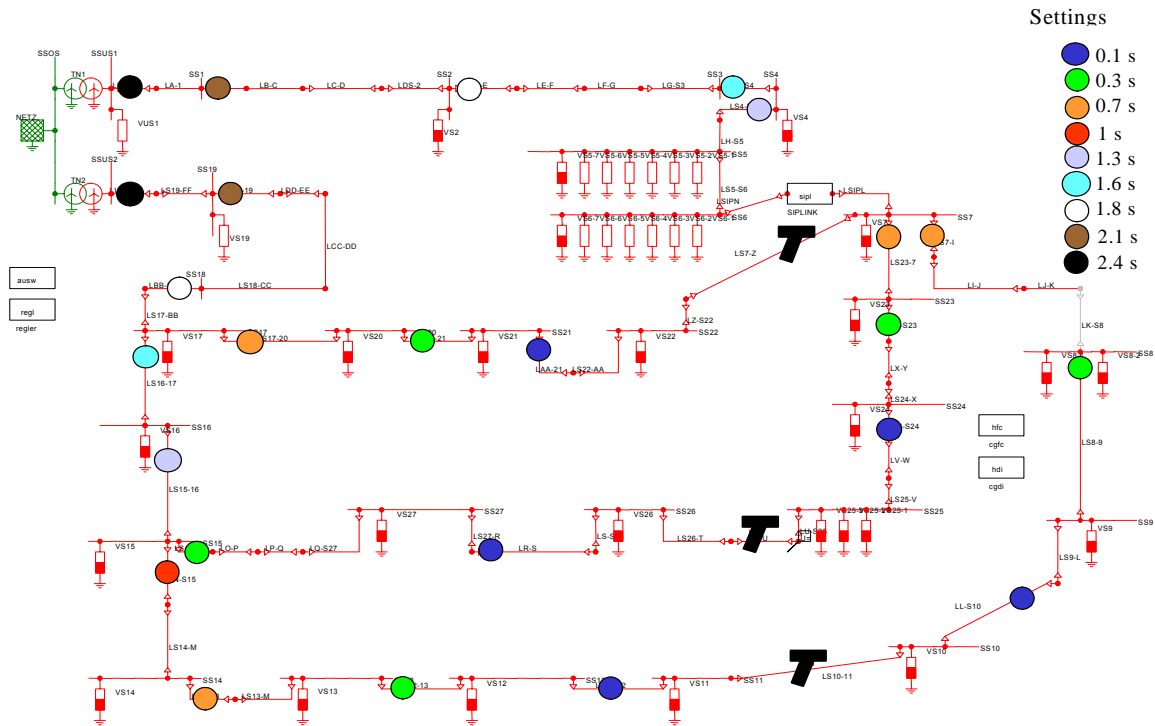

Fig. 6.10: Network protection in network II, Scenario Aa

Network II, Scenario B

Scenario B discusses the implementation of DER into network II. As presented in Fig. 6.11, in a few positions some DER (according to the natural offer) are connected to the network. The results of the simulations concerning load flow are similar with *Network I Scenario B*.

In case of a fault on a line in this network, the main system supplies the fault current. As a result, the short circuit power of the network and the amplitude and the duration of the fault current are also set from the main power supply. Their values hardly vary from the values obtained in scenario Aa and Ab. Due to this fact, there is no need to change any settings of any protection device in the network. Eventually longer lines could be protected with distance protection devices, which as a solution would have the impact of higher costs.

The most selective and expensive solution offers the differential protection set on both ends of each line in the network (see Fig. 6.11).

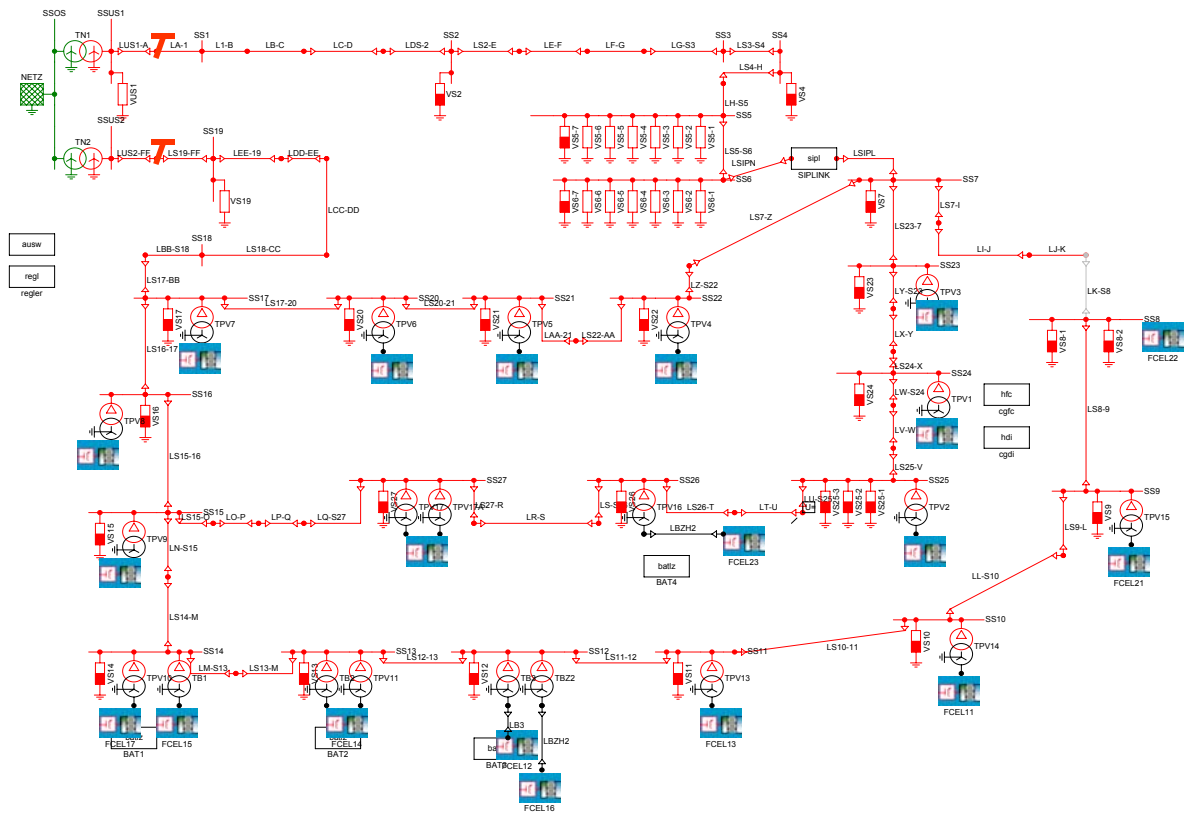

Fig. 6.12: Separation of the main power supply in network II – 20 kV network

6.2.3 Analysis of the simulation results

A few simulations of short circuit current calculation have been done in the two networks described previously. The simulations have also taken into account different amounts of DER that have been connected to the two networks. To test the settings of the protection devices, the following short circuit current simulations are discussed:

- 1) Network I and network II, Scenario Aa;
- 2) Network I and network II, Scenario Ab;
- 3) Network I and network II, Scenario B;
- 4) Network I and network II, Scenario C.

1) In the short circuit current investigation in network I and network II, Scenario Aa, the short circuit current in the network was generated from the main power supply and has values 10 -15 times the nominal current, the duration of the transient period is long enough for the protection device to detect and localize the short circuit current. Therefore, the demands of the protection criteria over-current are fulfilled. The settings of the protection devices have also been chosen correctly in order to meet the selectivity criteria. So the selectivity is reached with the lowest investment cost for the protection system.

2) In the short circuit current investigation in network I and network II, Scenario Ab, the circuit breaker is closed and a ring has been formed. The protection devices involved within the ring need to have a direction criteria in order to decide from which side the fault is coming and be selective.

3) In the short circuit current investigation in network I and network II, Scenario B, with the connection of DER to the network, the network changes from a network with single supply to a network with multiple power suppliers. In the case of a fault in the network with DER, the highest amount of short circuit current flows from the main power supply. The short circuit power from the main power supply is 150 MVA in network I and 250 MVA in network II, while that from the DER is in 5-5000 kW range. With this it is clear that the protection settings doesn't have to be changed.

4) In the short circuit current investigation in network I and network II, Scenario C, there is no connection to the main power supply of the network and with that the network is in island operation. In this case it is clear that the protection concept previously presented is not suitable for this condition. Namely, there is no large power supply that can fulfil the criteria of the protection principle over-current. The power supply in the network in this case comes only from DER and is in 5-5000 kW range. In case of a fault, when there are no communication channels between the protection devices from neighbouring substations it is impossible for the protection devices to decide if the fault is in forward or reverse direction. This results from the protection concept principle and the settings of the protection devices. Namely, the two basic requirements of the over-current and distance protection are the following:

- the short circuit current must be higher than the maximum overload current in all network feeders;
- the duration of the short circuit current must be longer than the delay time of the last upstream relay.

In Scenario C these requirements are not fulfilled. The fault current is limited from all energy supply sides of the network. The only possibility of protecting this network using the conventional principles is only by using differential protection for each line. The problem is, of course, the higher costs for the additional devices and pilot wires between the protection devices implemented on the both ends of each line.

Note: In the presented networks the DER connected to the investigated networks (network I and network II, scenario B and C) are connected via inverters that limit the injecting current in case of a fault in the network with a value of $1,1I_n$. The wind power plants can also be connected to the network via DFIG. In this case the network calculations should be carried out as in networks with multiple in feeds. The current contribution of directly connected DER must be considered in case of a fault in the network. The network protection concept can also be realised with directional and non-directional over-current protection devices [44]. Another possibility to solve the network protection problem in the case of multiple in-feed can be realised with so called zone protection. With zone protection, the investigated distribution network is divided into several zones, where one zone represents all of the lines connected to one bus

bar. Each zone is protected separately mostly with the over-current protection, the Kirchoff's law for currents and signalling technology [44].

In the following the case of an island operation in a network with multiple DER in-feed is presented. Other than using a main communication and decentralised protection system, the other possible solution for solving the problem of multiple in feed is also presented. In this case the change of voltage and frequency can give a criteria for selective network protection. Over- and under voltage and frequency relays can be used in this case [45].

Comparison with protection systems in current limited networks

The interest in devices capable of limiting fault currents grows together with the increased interconnection of the network, which leads to higher fault currents. In order to link and establish a stronger coupling of various systems sections without impairing stability or short-circuit behaviour, a new technology using super conducting fault current limiters (HTSC-FCL) and electronic high-speed circuit-breakers (ESI-switch) can be implemented. The benefit of the use of these elements is that the stress experienced by all components in the system is significantly reduced and the design can be much more cost effective [88].

In a substation such a unit is usually implemented in:

- the outgoing feeders;
- tie feeders (connecting feeders);
- incoming feeders.

The operational principle of a current limiter can be summarized in:

- reducing the magnitude of the fault current;
- switching off the fault current before reaching the peak.

A fault current limiter can limit a fault current passing through it within the first half cycle. Their use allows equipment to remain in service even if the prospective fault current exceeds its rated peak (Fig. 6.13). The current is usually limited to a value of three times the nominal current. In Fig. 6.13 two different types of current limiters are given (characteristics

in blue and green). It can be noted that the fault current limiter with green marked characteristic (semiconductor type) limits the current within few milli seconds and sets it to the value zero. The fault current limiter with the characteristic marked with blue (super-conductor) also limits the fault current in few milli seconds, but sets it to the nominal current value for max. 50 ms.

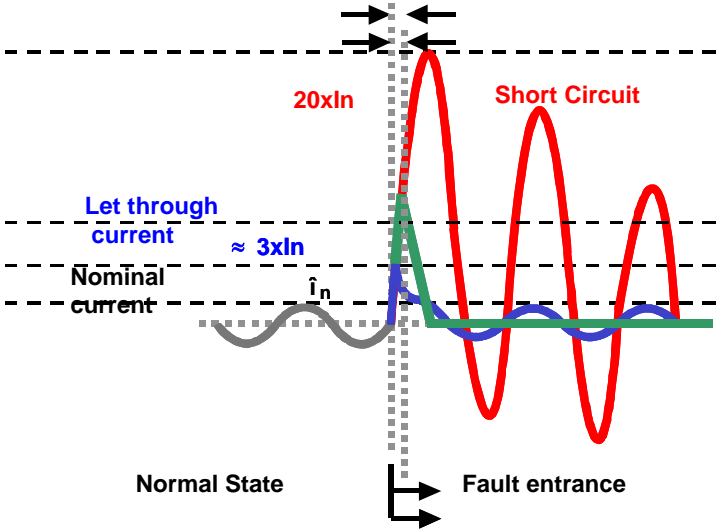

Fig. 6.13: Characteristics of fault current limiters

The protection system in the medium voltage network where the current limiter has been implemented suffers changes. Usually these networks are mainly protected by protection systems based on the principle of over-current. When the fault current is limited, the protection device sees no fault current and also no duration of a current higher than the nominal set current. Therefore, there is no need for the implemented over-current relay to send a tripping command to the circuit breaker. The limited or pass-through current is identified as the nominal current.

There are two possible solutions for this problem of unselectivity of the protection devices. The first new suitable solution uses the criteria of over-current protection, combined with the reverse interlocking as a criteria of line protection.

The principle of reverse interlocking will be explained in the following simple example (see Fig. 6.14). If a fault on one of the feeders occurs, all of the protection devices shown in Fig. 6.14 pick up. However, in order to satisfy the criteria of selectivity, only the protection device implemented

on the feeder where the fault occurred is supposed to locate it and send a tripping command to the circuit breaker to disconnect that feeder. The supply of electrical energy for the other customers (connected to the other feeders) should not be interrupted. As a back-up protection, the protection device located at the main feeder is about to disconnect the fault, but in this case all of the customers would be without supply.

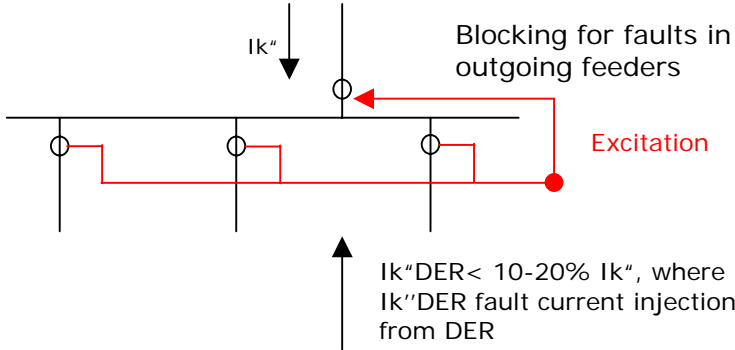

Fig. 6.14: Principle of reverse interlocking

With the implementation of the principle of reverse interlocking such a situation can be better managed. Namely, as soon as the circuit breaker from the feeder localises the fault present on it, it sends a blocking command to the main other protection devices at the other feeders. In case of a fault on the busbar, only the main protection device will disconnect the fault. If there are no other possibilities for energy supply, the customers will stay without power supply until this fault has been cleared.

The presented solution can be also implemented in networks with high penetration of DER as there are a few similarities.

As discussed before, the problems with the selectivity of the network protection can happen when the main power supplies is disconnected from the network, and the network is functioning as an island. Although, with regard to load flow, the DER supply the network with the needed power. But, in case of a fault in the network the requirements that the protection devices set to function properly are not fulfilled. This is explained in the Fig. 6.15 and Fig. 6.16. Namely, the injected fault current from DER has the value of 110% nominal current while settings of the protection devices are for 110% of the maximum line current. This means that during a fault on the line the value of the fault current through the line is smaller then

the set pick up current value of the protection device, which means no pick up. That means that the whole protection concept fails, due to a lack of excitation.

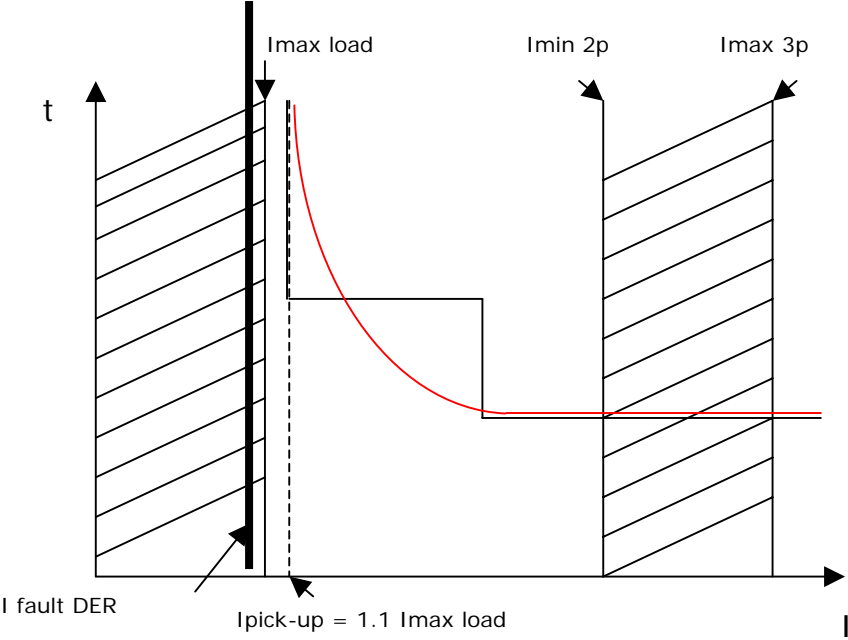
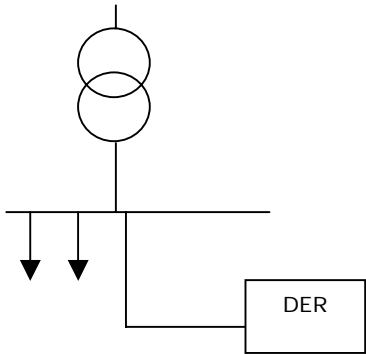

Fig. 6.15: Excitation current of the protection device and fault current from DER



$u_k = 6-12 \%$
 $I_k'' = I_n / u_k$
 $I_k'' = 8-12 I_n$
 $I_k'' \text{ DER} = 0.8 - 1.2 I_n$,
 since $I_k'' \text{ DER} = 10\% I_k''$
 $I_k'' \text{ DER} < I_{\text{max last}}$

Fig. 6.16: Calculation of the fault current of DER

6.3 Implementation of the possibility of recognising the fault current direction

This and the following Section discuss a few possible situations connected to the problems mentioned in Section 6.2.

In Fig. 6.17 a distribution line protected with two directional relays is presented. There is a communication channel between the protection devices through which a signal can be sent. This signal can either be a release signal if a fault is seen or a blocking signal if no fault is seen. No signal will be sent or received from devices which are out of operation. On this line the attitude of the protection devices during load flow and short circuit current flow conditions will be discussed. The direction of the load flow as well as the direction of the short circuit current flow through this line is presented in Fig. 6.17. Let's assume, for the purpose of these analyses, that the settings of the protection devices are set to manage the islanding operation, i.e. only DER are supplying the network and the main power supply is disconnected and that in the networks no overload situation can happen. That means that the protection devices are set to operate by current value of $1,1 I_n$.

Case 1 and Case 2 present the normal operation case of the line and therefore only the load flow for normal operation is calculated. In Case 1 the protection device (PD) 1 is excited and in the Case 2 the PD 2 is excited. These protection devices become excited during normal operation when the current flowing through the line reaches the value of 110 % of the nominal line current I_n . These protection devices (in the case 1 PD 1 and in the case 2 PD 2) are excited on one side from the criteria over-current (corresponding to their settings) and on the other side from the criteria direction. The line will be disconnected only when both PD 1 and PD 2 see the fault. However, the problem remains that one of the PD will always be excited in normal operation. The solution is discussed in the following text.

Case 3 presents the situation where the both protection devices see the fault. Namely, the fault happened inside the protected zone, so that both the tripping criteria direction and short circuit current are fulfilled. In this case PD 1 and PD 2 will both send a tripping command to the circuit breakers. Cases 4 and 5 present a situation when one of the PD (because

of internal problems) is out of operation and sees no fault current. In Case 4 it is PD 2 and in case 5 PD 1. This problem can be solved using the so called echo procedure. Namely, when a situation like this occurs, then PD 1 in Case 4 and PD 2 in Case 5 are about to send a tripping command to the circuit breaker and open the line because they receive no signal from the opposite PD, which means that the opposite PD is out of operation. Cases 6 and 7 present situations when the fault in the network happens outside the first protective zone of both PDs. Only the PD that sees the direction of the fault would send a tripping command as a back up protection.

Case 1		Normal operation: Load flow PD1 Excited PD2 Not excited
Case 2		Normal operation: Load flow PD1 Not excited PD2 Excited
Case 3		Fault inside the protection zone PD1 and PD2 Excited
Case 4		Fault inside the protection zone PD1 Excited PD2 Not excited
Case 5		Fault inside the protection zone PD1 Excited PD2 Not excited
Case 6		Fault outside the protection zone PD1 Excited PD2 Not excited
Case 7		Fault outside the protection zone PD1 Not excited PD2 Excited

Fig. 6.17: Possible situations during a fault on a line

6.4 New approaches in protection systems with DER

6.4.1 Introduction

The automation and protection relays are meant to ensure the system's optimal operation. The protection relay must provide fault detection and disconnection of the damaged element selectively and fast, in order to avoid fault extension, and to return the rest of the system to normal operation [15]. Today's power engineering is highly influenced by the changes in the power system that followed the deregulation, liberalisation, restructuring and privatisation, happening all around the world. Therefore, nowadays more than ever a very big importance is given to the substation automation and the network protection. The power companies of today require different approaches for making the utility industry more cost effective and responsive to customer needs. As a result, two important trends have emerged: the introduction of more automated functions and the use of more advanced information technology [46].

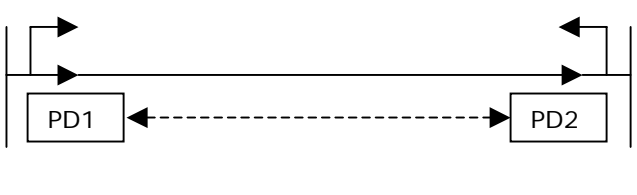
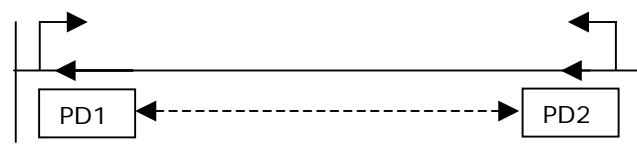
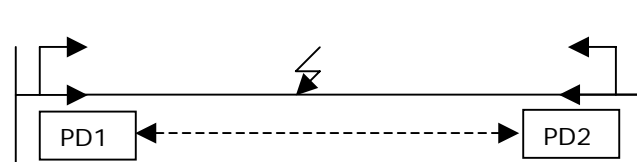
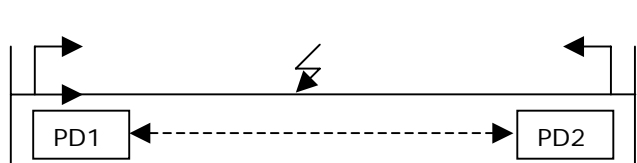
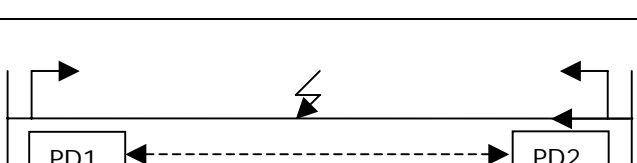
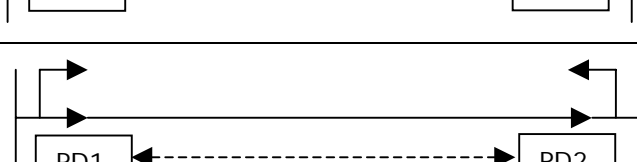
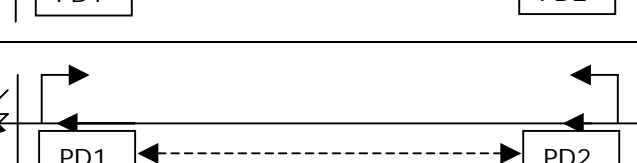
Remote terminal units

Historically seen, the first stage of using remote control and substation automation was the implementation of simple Remote Terminal Units (RTUs). These units have connected the mimic board and the control panel to the remote location for control and supervision purposes. The advantages of this system were that all the signals were in one processor and there was no need for communication among the processors, which simplified maintenance and configuration. The disadvantages of this solution were the weak processing power and no ability to follow the required functionality. The RTUs did not support enough communication ports and protocols to communicate with new protection devices which have more control functions. As a solution more processors were added so that the devices had the ability to communicate with each other. All of this encouraged the use of distributed control systems with integrated protection function. This solution quickly brought about other problems i.e.: higher costs, complicated system management and configuration, the need for high speed communication between CPUs, etc. In comparison with the service life of a substation, the different devices implemented in an automation system have short replacement cycles, and different generations of these devices may co-exist. When devices from different

manufactures or from different generations need to communicate with each other and if they use different communication protocols, gateways are mostly used to achieve interoperability. This solution is possible, but the disadvantages are that it is costly, with delays and errors in the communication [57].

Substation automation system

Emerging technologies in the field of information technology (IT) influence the secondary equipment in power systems, since more and more IT is used [51]. The IT relates to the technology for communications, processing, intelligent systems, computer networks, databases, user interfaces, etc. The implementation of IT for network protection purposes promises increased efficiency and quality of maintenance in secondary subsystems. The amount of data and the complexity of the network structure requires a very coherent data management system [57]. The final aim is to provide better service to the customers and to reduce the operating costs [54]. In Fig. 6.18 the development of the substation automation using the development of the implemented communication technology is presented.

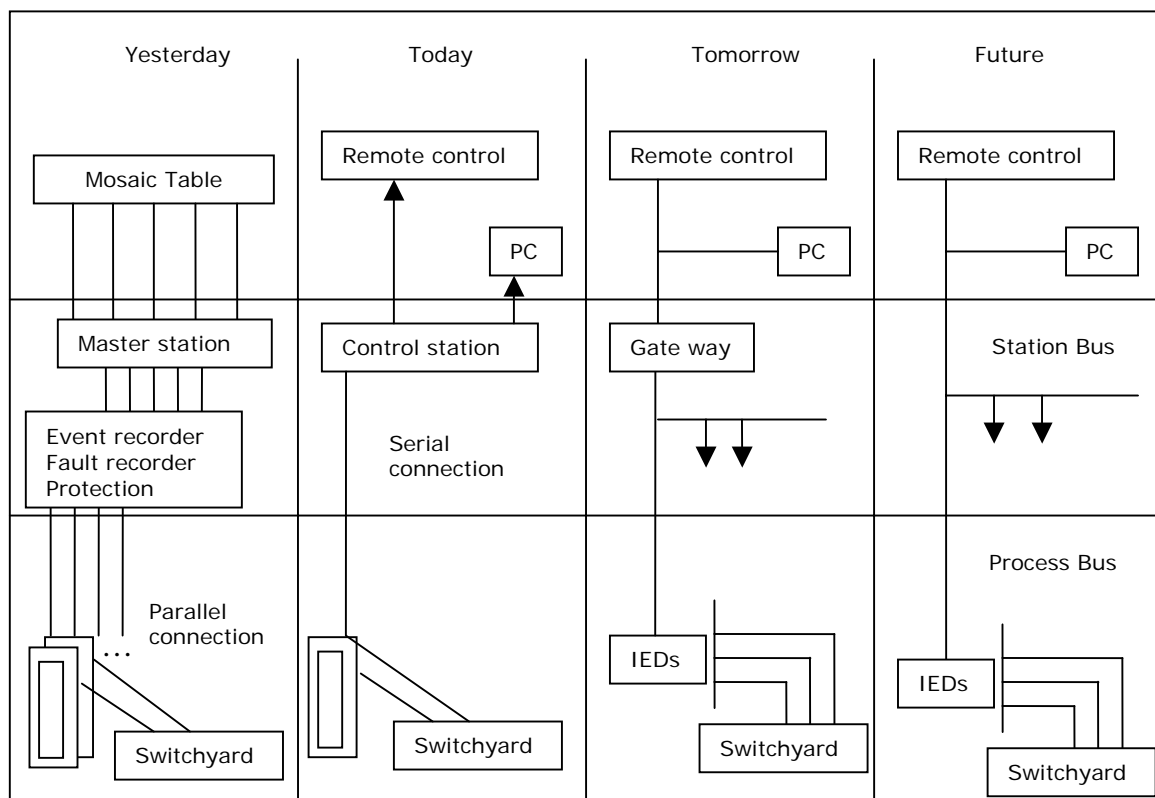

Fig. 6.18: Development of the substation automation

As a result of the technology developments, the following new requirements for monitoring and control are set [72]:

- ability to track the system changes very closely;
- ability to analyse the events and consequences automatically;
- ability to react to system changes quickly.

This new solution is presented using the Standards IEC 61850 and IEC 61970. The goals that are about to be reached with the implementation of the standards are the following [70]:

- From the user-point-of-view: the standards must support all the functions, that are present in the substations;
- Interoperability: the IEDs from different manufacturers must be able to exchange information between each other, as well as use these information for their internal functions;
- Flexibility of configuration: the standards must support different operational philosophies, as well as free settlement of functions, e.g. centralised or decentralised implementation;
- Long time stability: the standards must be future-safe, which means, that it must be able to withstand the development of the communication technology.

New approaches for system protection

- Adaptive protection systems

Adaptive protection is an online activity that modifies the preferred protective response to a change in system conditions or requirements. It is usually automatic, but can include timely human intervention [97]. An adaptive relay is a relay that can have its settings, characteristics or logic functions changed online in a timely manner by means of externally generated signals or control action. In other words, adaptive protection systems are systems which allow to change relay characteristics/settings due to the actual system state. For example, the primary zone pickup value of a distance relay can be changed online according to power infeed from a T-connected generator. The adaptive techniques use online

information of the system to optimise the protection system function. Some examples are: adaptive system impedance modeling (an up-to-date impedance model of the network that provides input data for a relay); adaptive sequential instantaneous tripping (for faults near the remote station); adaptive multi-terminal distance relay coverage (regarding infeed from T-connections in the relay settings); adaptive reclosure (prevent unsuccessful reclosure for permanent faults, high-speed reclosure in case of false trip).

- Wide area protection systems

The measured voltage and current phasors are transferred to a central computer where they are processed and used for monitoring, state estimation, protection, control and optimization. Such systems offer new opportunities for protection and control.

- Intelligent systems

Autonomous systems and computational intelligence are proposed as possible solutions for decentralized control. In this case adaption is reached by training the neural network to a certain performance, i.e. characteristic. The neurons can be trained in such a way that the normal behavior (circle) is adapted for high impedance faults.

6.4.2 The standards IEC 61850 - "Communication networks and systems in substations" and IEC 61970 - "Energy Management System Application Programming Interface"

Two emerging standards are related to the data interchange in substations – IEC 61850 and control centres – IEC 61970.

6.4.2.1 Definitions IEC 61850

In recent years the acceptance of the switchgear technology as "Substation Automation" with the functions of control, protection and monitoring has been accomplished. With the implementation of the Standard IEC 61850 an open communication in the substation will be reached. One of the main goals of IEC 61850 "Communication Networks

and Systems in Substations” is interoperability, i.e. the ability of Intelligent Electronic Devices (IEDs) from one or several manufactures to exchange information and to use it to perform the functions in an automated system. This also includes communication between the IEDs for protection, monitoring, metering, control and automation in substations. All applied IEDs have to fulfill the following interoperability [49] requirements:

- the communication standard IEC 61850 provides the *Objects* with all attributes and *Services* for the compatible data exchange;
- requirements regarding *functionality*, *performance* and *quality* in the domain substation automation have to be fulfilled;
- the *Engineering* has to take care that all the IEDs understand each other according to the „plug and play“ principle and that interactions with the surrounding domains (Fig. 6.19) are performed properly;
- since any installation built by components cannot be better than its weakest component, sustainability regarding quality assurance and long-term availability of compatible IEDs is important [58].

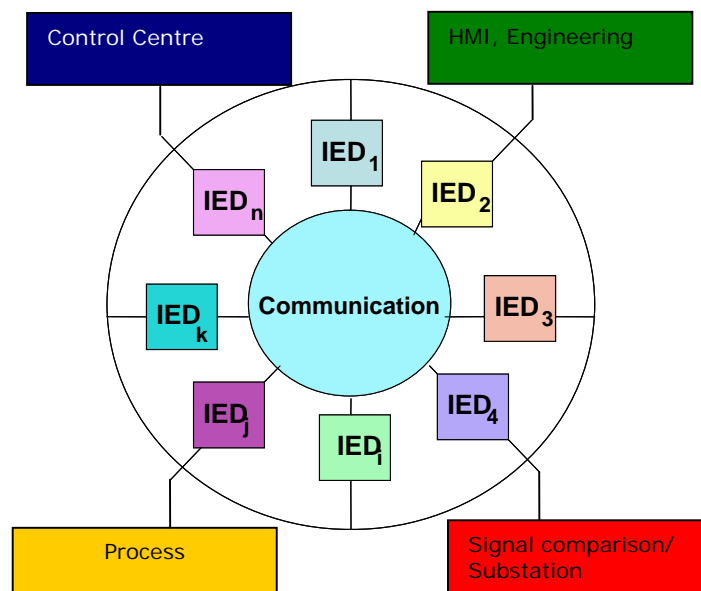

Fig. 6.19: Basic principle of IEC 61850 [58]

The functions in the substation are performed by the protection, control, monitoring and recording systems. A function can be divided into sub-functions and functional elements. The functional elements are the smallest parts of a function that can exchange data (communicate with each other) and are called logical nodes (LN) [46]. The LN may be implemented in a separate IEDs. The LN is an object such as, for example: a circuit breaker, insulator or grounding switch, current transformer, power transformer, switch control, measuring unit, automatic tap charger control, telecontrol interface, man machine interface, etc [52]. The LNs represent the basic object, such as the distance protection function in a line protection. Each LN has its own set of data. The data are exchanged following the rules which are called services [60]. Both the objects and services of Standard IEC 61850 have to be defined in such a way that all functional requirements of the process control by the Substation Automation System (SAS) can be fulfilled.

In substations, functions for control, automation and protection may be very complex and in order to have error-free performance they need to interact with some IEDs. For example, the distance protection works only by cooperation of the distance relay, current and voltage transformer, circuit breaker and HMI (Human Machine Interface). The last one is needed for presentation of fault information, reading and writing of parameters, etc (Fig. 6.20).

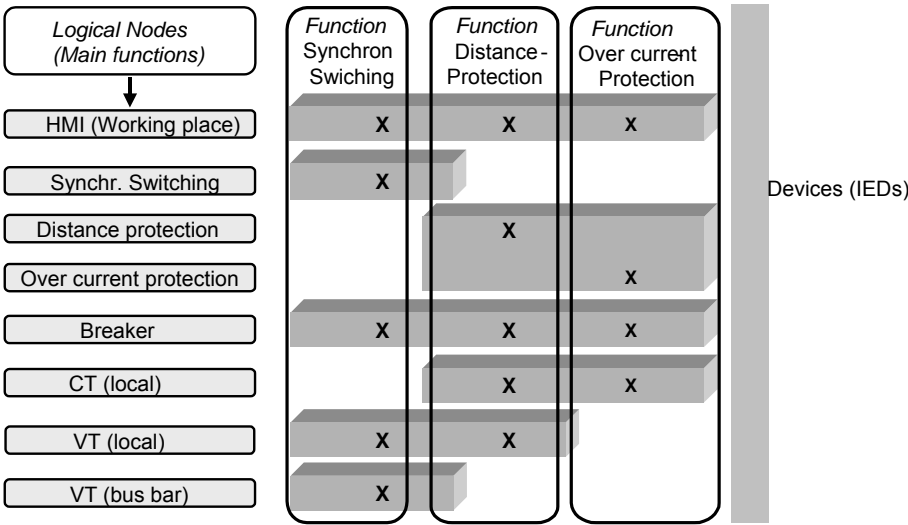

Fig. 6.20: Example for the allocation of functions and LN to IEDs [58]

In the following the most important function groups are listed [55]:

- system functions like control and time synchronisation;
- parameter- and configuration management;
- information presentation e.g. single line scheme, alarms, measured values, events;
- data acquisition of: topology or data changes, measured values, limit over reaching, faults, defects;
- network monitoring: e.g. fault analyses, power quality; monitoring of the primary equipment: switchgear, transformer, power lines; monitoring of the secondary equipment: e.g. watch dog by the protection devices;
- switchgear equipment (with interlocking, Synchro-check): switching with confirmation reply;
- protection of: power lines, transformers, bus bars, generators;
- automatic functions e.g.: synchro-check, re-closure.

6.4.2.2 Communication realisation with IEC 61850

The peer-to-peer communications in SAS are based on a Generic Substation Event (GSE). The GSE is based on the asynchronous reporting status of an IED's functional elements to other devices enrolled in the process. The generic data and services are mapped to a mainstream communication stack comprising Manufacturing Message Specification (MMS), Transmission Control Protocol/Internet Protocol (TCP/IP), and Ethernet. In this sense, the GSE replaces the hard wired control signal exchange between IEDs, for example, for interlocking and protection purposes.

The exchanged information can be divided into operational and configurational information [66]. Operational information includes status and control tasks and configurational information includes file transfer and changing settings tasks. Under real time conditions two other types of messages are also exchanged. Namely, the first type of message containing one or a few bits of information is mostly used for data

containing commands for blocking, release, tripping, indication of position of switchgear in automatic sequences, interlocking, protection and other data exchanges between peer devices. This type of message is called Generic Object Oriented Substation Event (GOOSE). The other type of message (Generic Substation Status Event (GSSE)) is for sampled values, used for sending streams of analogue data such as current and voltage samples [71]. The transfer of the real time data, settings and disturbance files is on a common 100Mbit/s network [48]. The data may be classified with regards to response or time requirements. The classes cover communication and response times between 3 ms (protection trip) and 1000 ms (file transfer). Also classes for time synchronization are defined ranging from 1 ms (time tagging of events) down to 1 μ s (samples, phases) [58].

6.4.2.3 Definitions IEC 61970

The Standard IEC 61970 “Energy Management System Application Programming Interface” (EMS-API) normalises a set of APIs for the manipulation of real-time critical, near real-time and historical EMS / SCADA data. The specification defines an elaborate model called Common Information Model (CIM).

The definition is object-oriented, for example: the CIM Measurement has relationships to MeasurementType and MeasurementValue. A number of Measurements can be attached to Terminal of conducting equipment, such as Breaker. The current position of a breaker can be defined with two data items:

`Breaker.Terminal.Measurement.MeasurementType.name` and

`Breaker.Terminal.Measurement.MeasurementValue.name`.

The above example shows that the common domain semantics standardises data exchange, irrespective of internal EMS/SCADA implementation models. It enables integration with EMS systems of different vendors, as soon as they provide the CIM view of their data and the IEC 61970 APIs implementation for exchange of that data [72].

6.4.2.4 Protection data management system

Once the relevant information is extracted, it can be distributed to multiple users responsible for maintaining the quality and reliability of the energy supply service. The real time serial bus technologies enable a large volume of data to be transferred between different components of the system. Various communication media can be used such as fibre optic cables or shielded copper cables. [47,48].

When the data are obtained from several types of IEDs such as digital fault recorders (DFRs), digital relays (DR), power quality (PQ) meters, remote terminal units (RTUs), sequence of event recorders (SERs), programmable logic controllers (PLCs) and circuit breaker monitoring (CBM) devices, then they can be analysed (Fig. 6.21). In this way the analysis includes both fault and power quality disturbances as well as detailed information of operation of switchgear and protection relays. These data are helpful for the managers (reliability and efficiency of the system operation), protection engineers (fault clearing equipment, protection relays), maintenance crews (switchgears operation), customer service (quality of power supply, fulfilment of power delivery contracts) and dispatchers (fault location and system operation restoration) [50,53].

Such a Protection Data Management System (PDMS) provides access to accurate and reliable information gathered by protection related devices, to aid faster and easier finding and solving of problems connected with the network protection system. An information system, which deals with dynamic information generated in different substations, has to execute the following main steps: data collection, data communication, data archiving and applying algorithms to generate information, information hosting for different user groups [53].

The initial collection of field data is done in numerical devices deployed for protection [55], monitoring or control. To benefit from this data at any time, remote access has to be established, which means sufficient communication facilities are a prerequisite, enabling data and information flow from the devices to the different user groups. Information generated from the collected data has to be presented in the way user groups are used to. Depending on the amount of the generated raw data and the storage and calculation capacity of the used devices, it might be advisable

to install data concentrators in the stations. This increases application speed, minimizes communication bandwidth and enables an economical use of storage capacity [46].

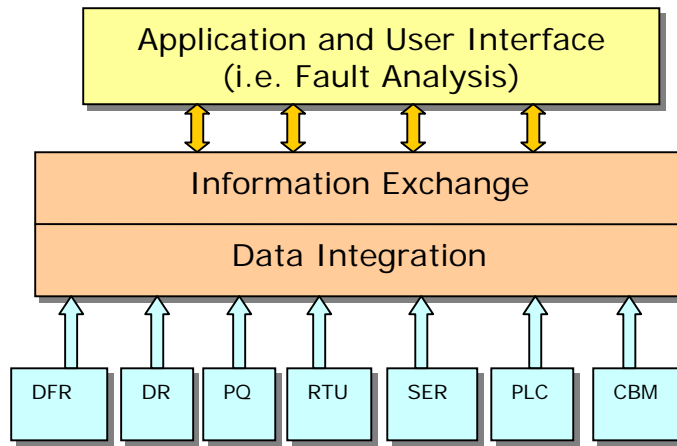

Fig. 6.21: Data integration and information exchange [53]

In this sense, protection management means handling, supervising and control of the protection system [66]. A model of the protection life cycle is presented in Fig. 6.22. The life cycle is divided into four functional sections: planning, standards & functional design; detail design & construction; commissioning & testing and operation & maintenance. Under the planning and standards functions, protection engineers are concerned with the requirements to put up a reliable, well coordinated and economic protection system based on acceptable standards. The functional design is derived to tighten up the planned requirements for implementation. In the detail design and construction functions, protection engineers ensure that functionality is included in the scheme. At the same time, the design and construction of protective system assemblies must also be simple and consistent to prudent utility practice. The commissioning and testing function involved in ensuring that the protective devices are properly interconnected and tested to verify its scheme and system integrity. They also certify that the system is finally safe for commissioning after applying appropriate settings. The protection systems are then maintained throughout their lifetime. During operation the working condition of the protection system is monitored until refurbishment is required to enhance the capability of the protection

system (see Table 6.1). Also this is done to provide indications for future plans [61].

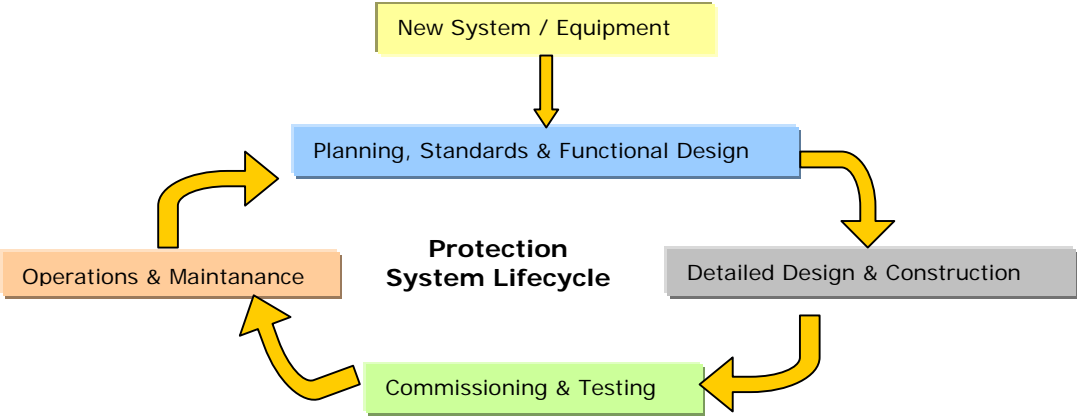

Fig. 6.22: Protection System Life Cycle [54]

The new protection system based on communication gives highest attention to security, availability and the wide range of required function, and takes into account the following guidelines: availability, security, dependability; application of well accepted standards; system scalability; flexibility ; and performance/price ratio.

Table 6.1 according to[61]

Type of Analysis	Functional Use	Frequency of Analysis
Reliability and Economic	Planning	5-10 years
System Impact	Planning	Major Project
System Review	Planning	2-3 years
Operational	Operations	Short-term changes (1-6) months
Settings & Coordination	Planning/ Commissioning	Every new system added
Investigative	Operations	Every system fault
Performance Audit	Operations	Yearly

6.4.2.5 Substation Automation System (SAS): realisation and availability

The traditional approach to data acquisition and processing for the control and protection assumes that the needs are served by independent instrumentation and controller infrastructures. Protective devices are connected directly to the switchyard via dedicated wiring typically terminated in the substation control house where the protection is installed. The Energy Management System (EMS), responsible for the overall power system control, is connected to the power system via Supervisory Control And Data Acquisition (SCADA) system. The SCADA system acquires and processes field data through RTUs that are wired to the substation switchyard and located in the control house [73]. In today's practise, the local substation protection and control solutions are independent from EMS and SCADA systems, and there is no data integration or information exchange. In addition a variety of monitoring devices are installed at the substation level for the purpose of acquiring and processing substation field data. This equipment is independent from the data acquisition and processing infrastructure for the system control and protection. The information exchange between these two types of equipment is limited. The main characteristics of the SCADA and EMS are:

- network-wide action with utilizing static or quasi-static view of the power system, handling of long-term non-dynamic phenomena in power systems, provision of a steady state data in slow time intervals,
- no ability to take any kind of dynamics, either control actions or oscillation, BUT they can operate coordinated with other systems and equipment.

The standard IEC 61850 presents a new solution for the substation automation system. Namely, most functions in substations are divided into three levels; station level, bay level and process level (Fig. 6.23). It is very common that the IEDs providing these functions are also allocated to these three levels [49]. The station level contains components such as SCADA, System protection unit, remote control, gate way and firewall, real time signal receivers and others.

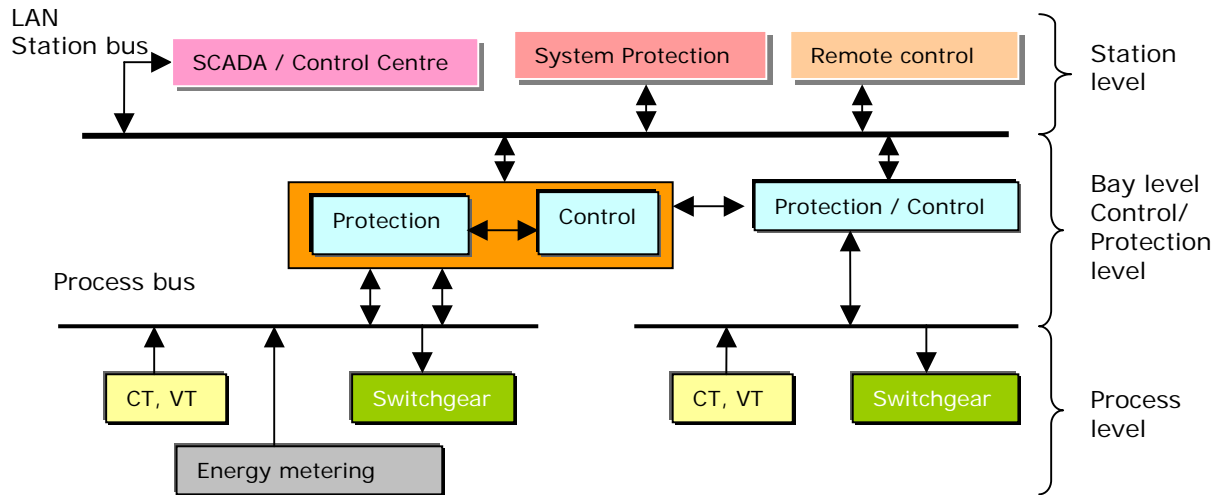

Fig. 6.23: Example of configuration of a substation automation system (SAS)

These components are interconnected with the bay level and between each other via a TCP/IP based Ethernet station bus. The bay level units contain an extensive range of protection and control functions which represent the heart of the system functionality [60,65].

The standard IEC 61850 focuses on a subset of interfaces (IF) shown in Fig. 6.23 and listed below:

- IF1: protection data exchange between bay and station level;
- IF2: protection data exchange between bay level and remote protection;
- IF3: data exchange within bay level;
- IF4: CT and VT instantaneous data exchange (especially samples) between process and bay level;
- IF5: control data exchange between process and bay level;
- IF6: control data exchange between bay and station level;
- IF7: data exchange between substation (level) and a remote engineer's workplace;
- IF8: direct data exchange between the bays especially for fast functions like interlocking;
- IF9: data exchange within the station level;

IF10: control data exchange between substation (devices) and a remote control centre.

The main feature of the SAS is a very high processing capacity [57]. Each unit can simultaneously manage several bays and they can work in parallel to provide increased redundancy. These units are connected to the primary equipment via a real time process bus with intelligent I/O (input/output; reading and writing) units of the process level located directly in the switchgear. I/O units perform all necessary input signal pre-processing like A/D conversion, digital filtering, phase calculation, etc.

The approaches of the standard IEC 61850 present a solution of [73]:

- integration of the protective system;
- integrated SAS;
- EMS integrated with SAS;
- total system integration.

In the sense of the total system integration the present idea solution in the area of Wide Area Monitoring Systems (WAMS) are meant. The WAMS are based on accurate measurements, have ability of load monitoring and fast control of network controllers. The Wide Area Protection (WAP) might be seen as a part of WAMS. The main characteristics of WAP are:

- presenting a dynamic view of the system ,
 - management of all kinds of stability and cascaded outages,
 - taking fast, optimised and coordinated actions.
- The benefits of the implementation of the standard IEC 61850 for the SAS can be presented in the perspectives of: planning, operation, engineering, and maintenance. The improvement of the protection functions, substation control, EMS control and the system wide monitoring are also a consequence of using this standard.

To calculate the system availability, component availabilities taken into consideration are given in Table 6.2 [57].

Table 6.2: Component availabilities according to [57]

Component	Availability
Transducers (T)	1 hour/year – 99.988%
I/O unit (card)	1 hour/year – 99.988%
CPU unit (P)	6 hours/year – 99.931%
Communication unit (C)	12 hours/year – 99.863% (not calculating communication line outage)

Availability for units connected serially can be calculated as:

$$A = (A1 * A2 * A3 * ... * An) \quad (6.1)$$

And for units connected in parallel

$$A = (1 - (1 - A1) * (1 - A2) * ... * (1 - An)) \quad (6.2)$$

Availability in classical solution with RTU is:

$A = AT * AI * AP * AC = 99.77\%$, which means 20 hours of outage for the control.

The availability situation for the protection is essentially better:

$A = AI * AP = 99.919\%$ with 7.1 hours of outage only.

Using a distributed system means a certain improvement, concerning the availability, but not so much in absolute figures, more in the fact that the whole substation can “never be lost”. Calculation shows:

$A = AI * AP * AC = 99.782\%$, which means 19 hours of outage for control.

The availability of the protection stays the same:

$A = AI * AP = 99.919\%$ with 7.1 hours of outage.

The new system architecture presented in this Section changes the picture with redundancy. With only two parallel CPUs can be calculated:

$A = AI * (1 - (1 - AP * AC) * (1 - AP * AC)) = 99.987\%$, that means 1.1 hours of outage for control, as well as for protection.

Comparing these results, with the results before, it is evident that the availability of the control has improved nearly 20 times, and the availability of the protection system 7 times.

6.4.3 Communication in distribution networks with DER

As uncertainty in power systems grows resulting from deregulation and liberalisation on the energy markets, power system protection concerning the secure network operation will play an increasingly important role. With the implementation of DER on the distribution systems and corresponding changes on the power flow, new requests are expected to be set to the protection devices (PDs). In such a complicated network structure the requirements of the PDs are rising. The importance of faster fault clearing times and better selectivity, smaller outage areas, etc. in a deregulated energy market is becoming very important. Nowadays, sophisticated protection relays can not only rely on logic installed in the microprocessors. A secure communication for fast data exchange between the devices is also becoming essential [61]. The Internet protocol (IP) based networks using the wide area time transfer system GPS (global positioning system) have been widely employed for power system communication. In some countries like Japan [62] and the USA the IP based networks have already been successfully used as communication links within, to and from control centres and substations [52,56]. Also, the PD communication is ready to be put to use.

The settings of the protection systems of today were made when DER were not present in the distribution network. Since the implementation of DER in the power systems, an analysis of the settings and protection concepts has to be made. Changes of the protection concepts are possible, depending on the amount of short circuit current in feed from DER. But, a secure decentralised protection is possible with the well-known protection criteria of today: over-current (grading for radial networks and directional grading for networks operating in rings), differential, distance, etc. With this the principle of primary and back up protection can be successfully realised. The implementation of DER on the distribution network and the secure operation on the networks today relies on communication and management systems. The data of the weather forecast (wind, water, sun), other forecasts (gas, biomass), energy generation in ¼ hours day profile, energy import–export, energy storage, the DER application, online-optimisation, etc. are managed by the energy management system. The control stations via communication links inform the DER of their schedule application [62,64]. The communication can be

realised using radio communication links, power line communication (PLC), ripple control, etc. With the possibility to implement the communication as a part of the protection system, a few ideas are applicable.

As a visualisation of the functionality of the new protection principle an illustration network is given on Fig. 6.24. The “decentralised” protection in this variant is going to be seen as a back–up protection system. This „decentralised” protection is equal to today’s state of the art over-current, distance or differential protection (explained previously). The “decentralised” protection is of course parameterised with the necessary settings to satisfy the criteria of back up protection in the sense of selectivity. As a primary protection system, protection scheme based on a phasor and state of the circuit breakers is proposed as an extension of the energy management system. The installed numerical protections are able to measure and to transmit time-stamped phasors of the voltages and currents to the system protection unit installed at the energy management system. If protection systems with local control function are used, they can also provide information about the feeder (state of circuit breaker, grounding switch and isolators).

If there is a fault in the network, the primary protection is the one that should localise the fault and send via the communication link the tripping command to the circuit breakers. If there is a faulty communication, the main protection role uses the “decentralised” back–up protection with a delay time of 200–300ms.

It is important to stress that this new solution based on communication also requires also a sensor type of current transformers, according to the higher sampling rate.

As said before this protection method is based on phasor measurements. Phasors are presentation of U and I at diff. buses of power system and they define the state of the power system using DFT. The main characteristics of the phasors are:

- phasor is a complex number associated with a sinusoidal wave;
- phasor magnitude is the same as the sinusoidal wave magnitude;
- phasor phase angle is the phase of the wave at $t=0$;

- phasor is associated with a single frequency;
- the time dimension is removed from the phasor based Eqs.;
- phase is the indicator of the dynamic performance of the system with the swing Eq., machine oscillating modes can be determined by measuring the phase angle of the positive-sequence voltage phasor at the machine terminals.

In this sense a transient state on a power network is a condition in which the magnitude, phase angle, or frequency of one or more bus voltages become a function of time.

The phasor measurement follows with a reference determinate in the moment of measurement. Essential is synchronisation of the sampling data. Today synchronisation accuracies of order $1\mu\text{s}$ are possible. The time tagged phasor measurements in SPC can be compared with the data from a previous instant, which can be used for control.

The idea and a basic realisation of the implementation of communication for the purposes of protecting a line will be presented in the following [67]. The network presented on Fig. 6.24 contains 7 busbars and 8 lines. Each circuit breaker (two at the ends of each line) can be tripped either by the bus bar protection, line primary protection or directional over-current protection located at each substation.

The necessary information collected at each substation includes:

- the current values (magnitude and direction) of all feeders connected to the station;
- the network topology;
- the status of all PDs and circuit breakers located at every station.

The information sent to the neighbouring stations includes: the identification of the confirmed faulted line (CFL), if one has been found; and the status of the local PDs and circuit breakers. Once a decision of CFL is made, locally or from a received message, a proper delay time for every PD in the network according to the stored network topology will be sent. For the exchange of data power line carrier, microwave, pilot wire

The communication between the substation and the PDs can be achieved via a local area network (LAN) within a substation or via a dedicated link. The communication between neighbouring substation can be realised via a wide area network (WAN) or dedicated link. The algorithm for the internal data exchange as well as between substations is given in Fig. 6.25.

In case of a short circuit, the primary protection is the one that should localise the fault and send the tripping command to the circuit breakers via the communication channel. In case of a faulty communication, missing data, or other problems, the “decentralised” back – up protection takes over the protection role and clears the fault with a time - delay. In this sense, this protection is required to operate only when the main protection fails to clear the fault.

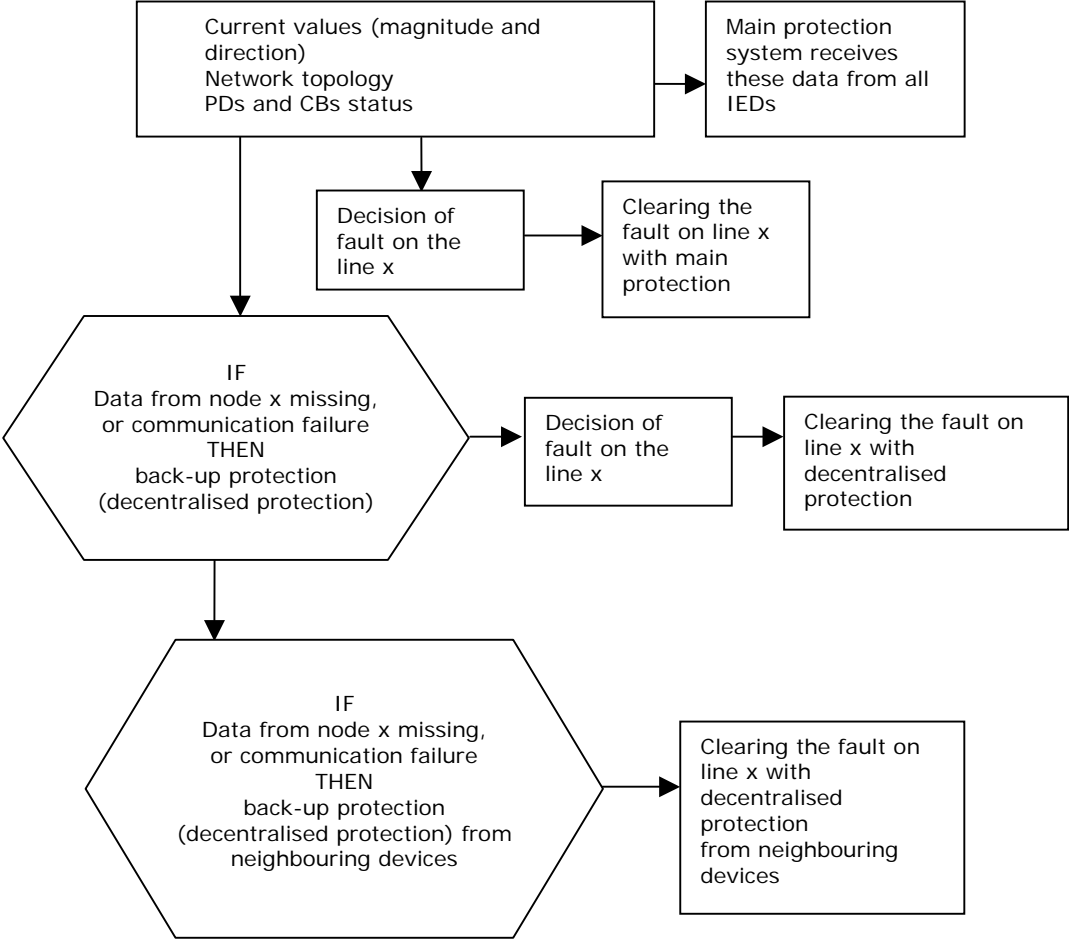

Fig. 6.26: Block diagram of the protection algorithm

The primary protection with the help of logic functions and using the received phasor data, network topology and the status of the circuit

breakers locates the fault in the network [68]. This procedure is given in a block diagram in Fig. 6.26.

In the following paragraphs, simulations of a small network will be shown and the protection scheme discussed in detail. As an illustration of this principle see Fig. 6.24. A fault as shown on the Fig. 6.24 is considered. The main protection system according to the presented procedure locates the fault and sends in the shortest possible time a tripping command to the circuit breaker on the line protected with the protection device 14

If the main protection unit fails to operate during this fault, the decentralised protection, namely the protection device 14 will clear the fault with appropriate time delay.

In case of mal function of the circuit breakers located on this line, the neighbouring substations will get this information as well. The protection device 9, and the protection device 7, are set to operate in a delay. These units will clear the fault. With these characteristics, this protection concept characterise itself with high reliability [67].

In the presented example the management of the measured data is realised within the system protection centre (see Fig. 6.27).

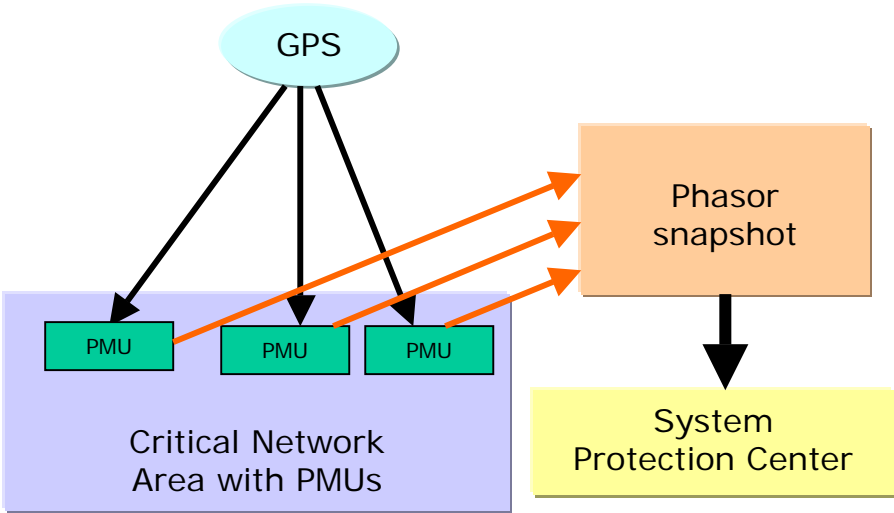

Fig. 6.27: Structure of WAMS

The WAMS contain the following hardware units:

- phasor measurement units (PMU);

- communication links;
- central unit – PC.

The PMU contains the units given in Fig. 6.27a. The main application of a PMU are:

- state estimation – most important part of monitoring the power system,
- instability prediction – real time stability analysis,
- adaptive relaying - dynamic relay settings enabling a better response to power swings,
- improved control of power systems – direct feedback to controllers (VSC, UPFC, etc.), dynamic control of the power system.

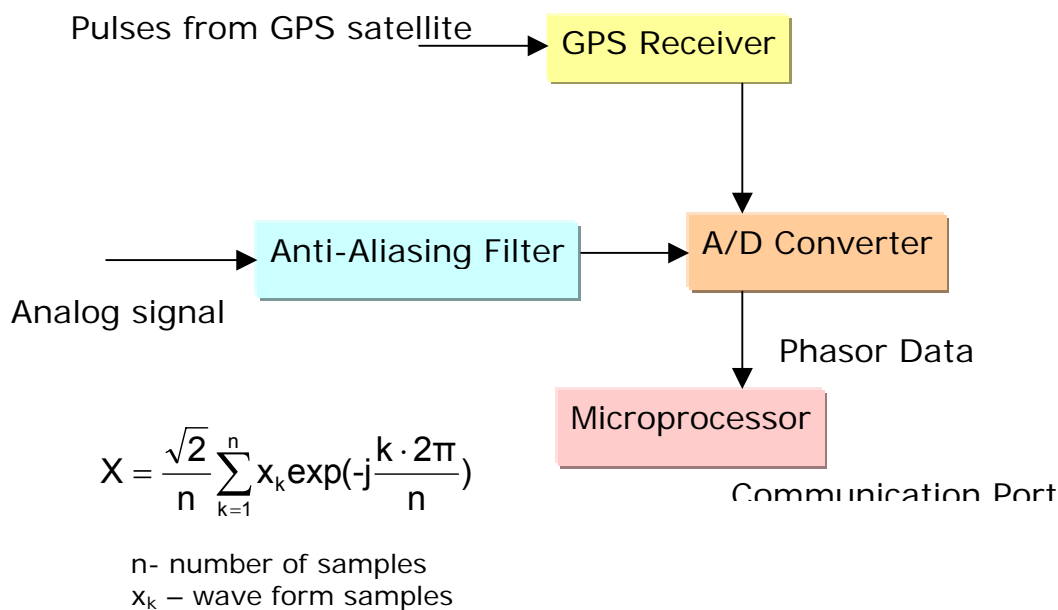

Fig. 6.27a: Basic block diagram of PMU

The system protection centre collects, synchronizes and sorts collected measurements. The ability to provide needed data for any application, as well as the robustness (resistance against poor quality of input data) and the fast execution are obtained.

6.5 New concept of network protection based on additional signal injection

Another possibility for the protection of the network is injection of a signal with additional frequency (e.g. 120 kHz) or an interharmonic, non-characteristic frequency into the network at a specified position. This signal will be measured on each feeder in the substations, either by newly installed logical units or by extended numerical relays. This new protection scheme, based on a non-characteristic frequency, has only one source in the system, the fundamental frequency has multiple sources from the networks as well as by DERs. This logical protection scheme uses the well-known reverse interlocking.

As an illustration of this principle see Fig. 6.28 and Figs. 6.29a-e. This idea will also be shown in a simulation of a small utility network.

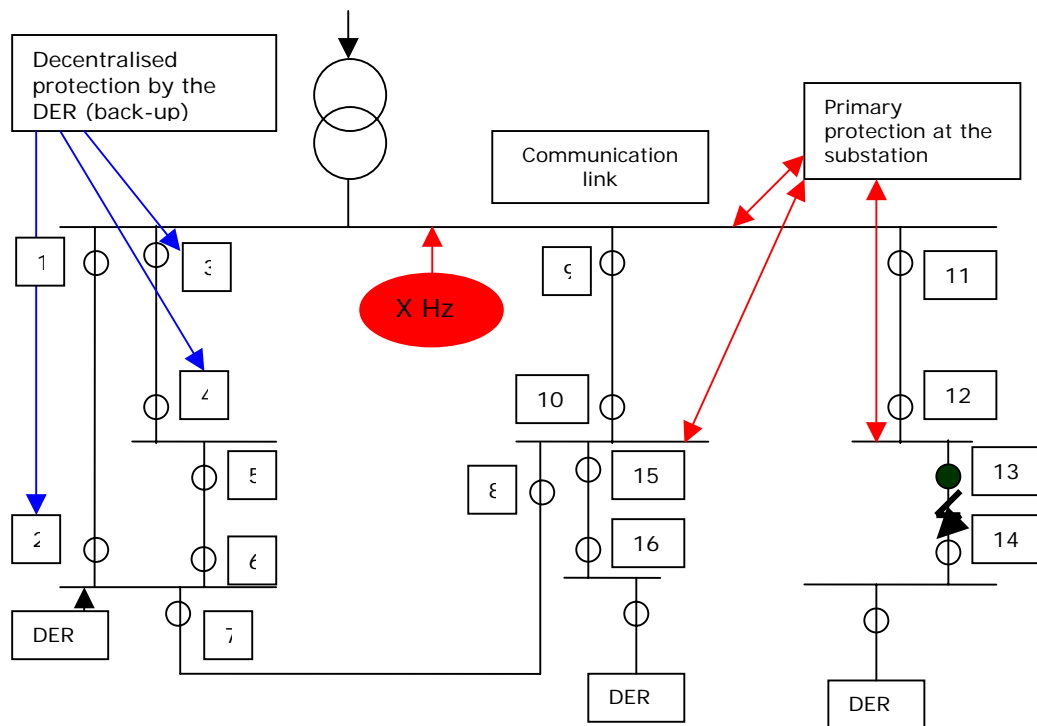

Fig. 6.28: The idea of using signal injection for protection systems

In the presented network a signal with a frequency of 80 Hz has been injected. The signal has been measured at all nodes in the network as presented. In a case of a fault on the line 1, this signal will be measured everywhere except on the faulted line and on the following node. The

protection principle can be realised simply by using the reverse blocking function.

In MATLAB the presented test network has been realised for investigating this fault location method. In the test network (Fig. 6.28) a signal with $f = 80 \text{ Hz}$ has been injected.

In the following diagrams the results of the analysis of the signal spreading through the network with and without a fault present in the network are presented. The first column of the table presents the frequency spectra of the measured signals on three different nodes of the network: between line segments, on the spot of the fault and on the load node, before a fault has occurred on the protected line.

Fig. 6.29a and Fig 6.29b present the frequency spectrum on the node between the line segments (Fault Locator 1), zoomed frequency spectra are presented. Fig. 6.29c and Fig 6.29d present the frequency spectrum on the fault node between the line segments (Fault Locator 2). Fig. 6.29e and Fig. 6.29f present the frequency spectrum on the load node (Fault Locator 3).

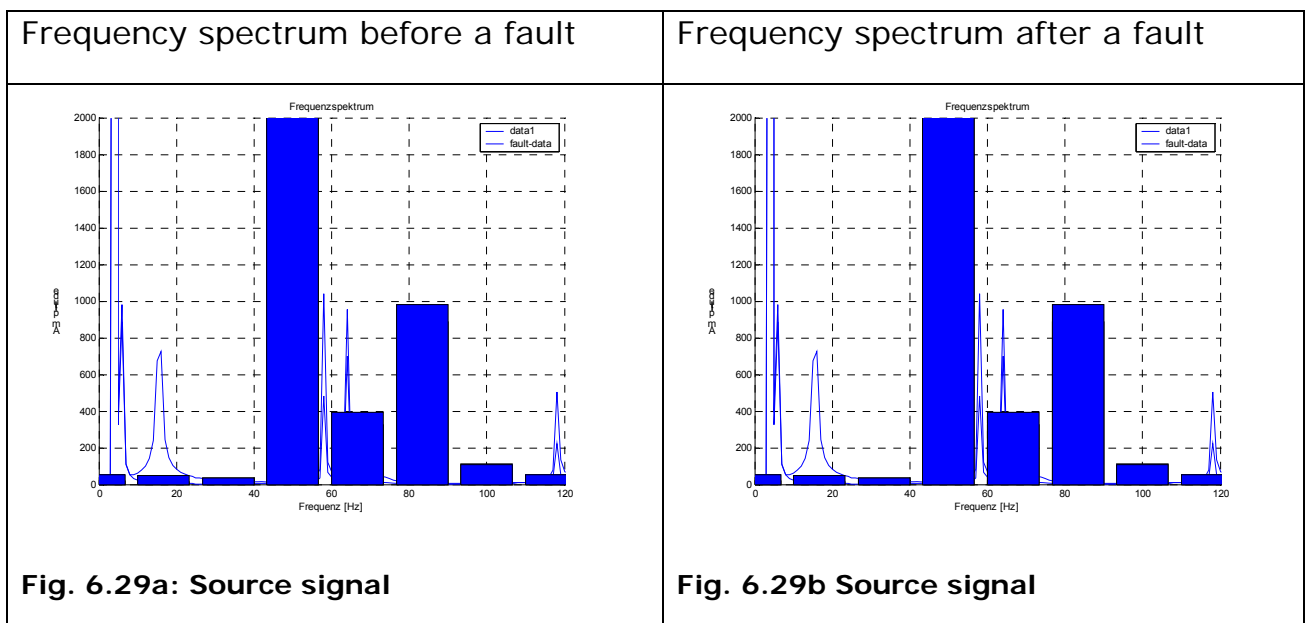

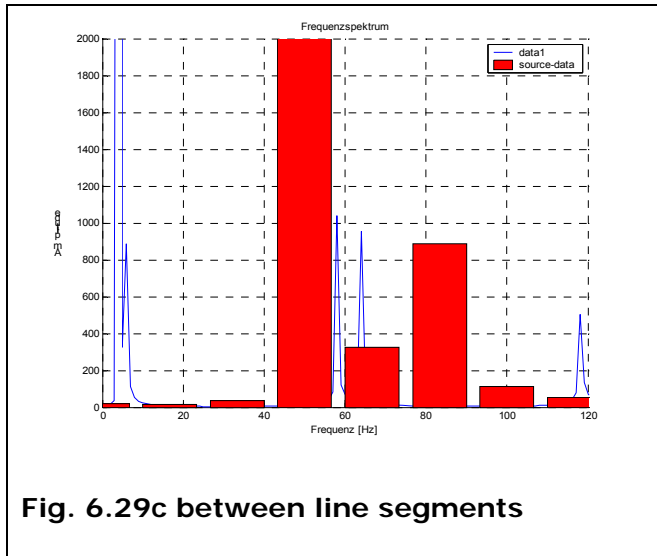

Fig. 6.29c between line segments

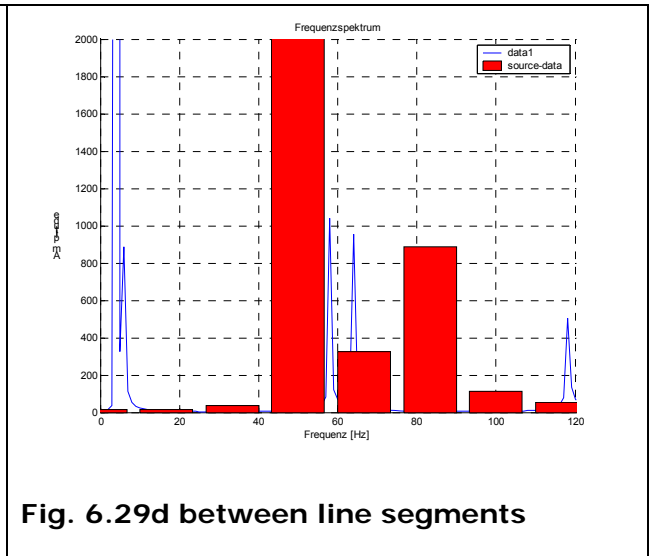

Fig. 6.29d between line segments

For the analysis of this fault location method the figures of the frequency spectrum measured at the point of load are important. Fig. 6.29e gives the frequency spectrum on the node Load before the occurrence of the fault on the line.

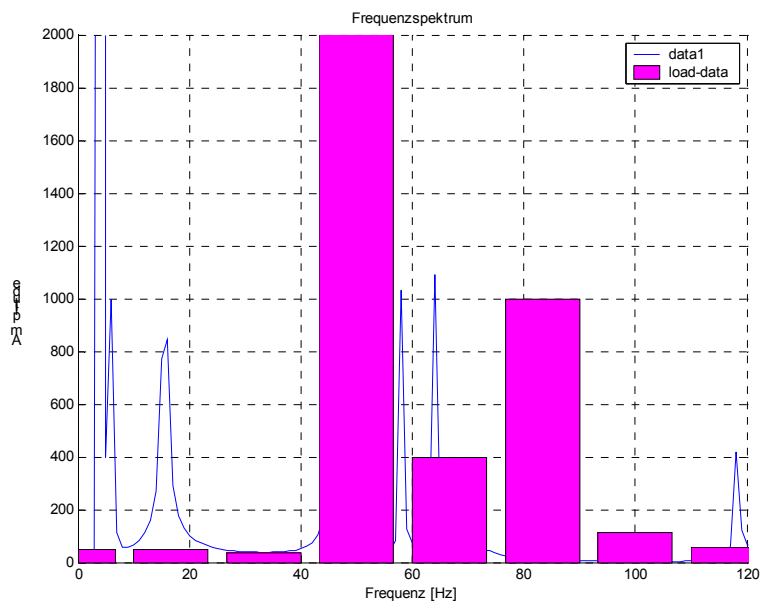

Fig. 6.29e: Frequency spectrum on the node Load before the fault

As it can be seen in Fig. 6.29f the injected frequency of 80 Hz is measured with the amplitude of $A = 1000$ V.

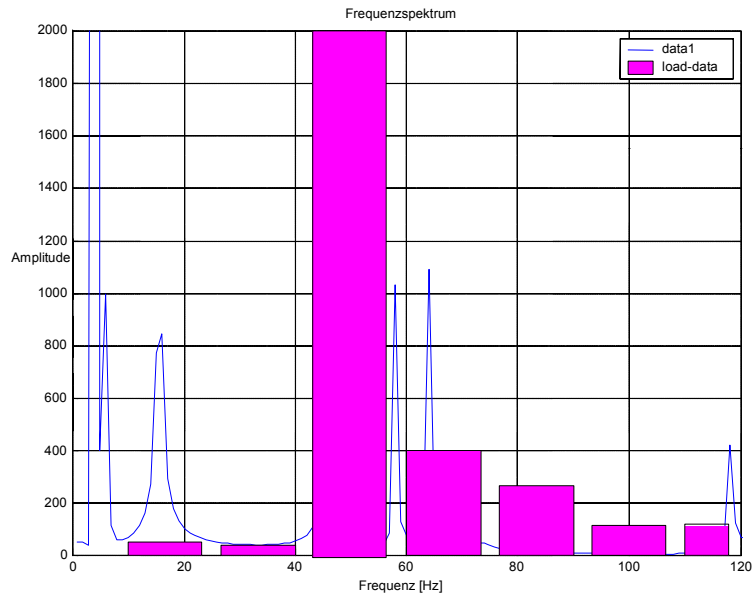

Fig. 6.29f: Frequency spectrum on the node Load after the fault

When a fault occurs, the amplitude of the injected signal on the node Load drops to a value of $A = 220 \text{ V}$. With this, the fault locator unit can inform the main protection device that on the line segment before, a fault has occurred (see Fig. 6.29f).

7. E- learning – The new teaching method

7.1 Introduction

During recent years traditional education system has changed to a new way of teaching, namely e-learning, in order to keep up with the modern society. The modern society is challenged from the global orientation of the world economy, strong competition and the change of the social structure. Furthermore, modern information and communication technologies are transforming the way people learn. With the advent of the Internet and the multiple formats that can be communicated over the World Wide Web, there are now several new and exciting ways to present teaching information. The two principal features of the e-learning platform are the delivery of information and data, in electronic format as didactical units e.g. courses, lessons and checking of the training results. Hypermedia offers a great potential as a framework for modern e-learning tools as it allows for the incorporation of constructive learning strategies. The new information techniques make it possible to optimise the requirements of a modern society, so a lot of institutions for higher education throughout the world are developing and offering new teaching methods to the students, as so called virtual teaching [70].

Protection technique as one of the fundamental disciplines of power system engineering has always played a very important role in the security and reliability of electric power systems. The safety of electrical power systems and the protection of electrical equipment benefited with the advance of microprocessor technology implemented in protection technique. Yet, because of the complexity of the electrical power system and influencing factors mentioned in previous chapters, protection technique remains a challenging discipline [71].

The presentation of the realised e-learning course is as follows. In 7.2.1 the structure of the teaching tool is presented. In 7.2. the chapter contents and the realisation of the teaching tool are explained. The results, namely the feed back from the users of this e-learning course, are given in 7.3.

7.2 E-learning system - Virtual protection technique

7.2.1 Structure of the e-learning system

The module “Virtual Protection Technique” is realised as a group of chapters: Basic Principles of the Digital Protection Devices, Fuses, Over-current Protection, Differential Protection, Distance Protection, Over/Under Voltage Protection and Over/Under Frequency Protection [12]. The basis for the realization of the E-learning system is a theoretical scenario based on the existing lecture [74-86]. In developing the modules, the first goal was to capture the attention and then encourage the interest of the student. In order to be able to convey the content with some charm, a lot of attention has been paid to construct clear and straightforward ways to introduce the teaching concepts. This has been realized for example, by using different types of animations and introductory videos. All the chapters are available from the main menu of the module. The logical structure of the chapters enables the student to easily follow the study material. The imparted knowledge is divided into two parts: the first part is the basic knowledge constructed mainly as small text blocks, joined with figures, tables, graphics, animations -acoustic and non-acoustic- and simulations. The second part is the deepened knowledge, additional contents of teaching, internal and also Internet links. It is also possible to download the teaching materials. Generally the chapters are divided into basic principles, function and implementation on the power system of each of the discussed types of protection. The teaching module is supported with numerous MATLAB simulations that give an illustration and visualisation of the complexity of the protection technique.

7.2.2 Chapter contents and Realisation

The first chapter - Basic Principles of the Digital Protection Devices - gives an introduction to the power protection technique. In this chapter the elements that one digital protection system contains, in order to fulfil the task of protection are given. The task of protection of the electrical equipment and personnel from over voltages, short current and so on, as well as the principal function and the implementation of the power protection technique in the network with the different types of protection

devices are explained in this chapter. This chapter also includes a report of the development of the protection devices (mechanical, electrical, digital) and definitions of the requirements of the modern digital protection devices [75]. The confrontations between some of the requirements (for example promptness and costs) are also explained and some problems concerning this are discussed. The student has the possibility via external links to get additional information directly from a few manufacturers listed on the site. Fig. 7.3 and Fig. 7.4 give some of the basic protection principles. Fig. 7.3 shows the basic protection principles like: over-current, current – difference, current – phase angle – difference and the method of calculation using the symmetrical components. Fig. 7.4 shows the basic protection principles like: impedance, power direction, over and under voltage, frequency and also some additional criteria for fault location like temperature, etc. By clicking on the type of protection of interest to the user, one can get further additional information (deepening knowledge). The student has the possibility via external links to get additional information directly from a few manufacturers listed on the site [77].

The second chapter - Fuses - discusses the functional principle of this type of protection and in a few examples shows its implementation in the network. This type of protection is usually used for protection of distribution lines and small transformers on the low voltage level. Some examples from the industry implementation of fuses are also given.

The third chapter – Over-Current Protection - discusses its functional principle and implementation in the network [15]. An algorithm of this type of protection is also presented. The function of the protection is illustrated in a few MATLAB simulations. Fig. 7.5 is an illustration of this chapter. Namely, it presents the different types of over-current protection principles. Also, an example of time grading of the over-current protection devices in one protected distribution line is given, and a basic algorithm presenting the principle of function of one over-current protection device is shown. This chapter shows how a student gets familiar with the realisation of one over-current time dependent digital protection device. Step by step procedure of programming in MATLAB is explained. The student has the possibility of changing a few parameters (time settings) of the protection device and with that she/he can make some conclusions concerning the function of this type of protection devices on her/his own.

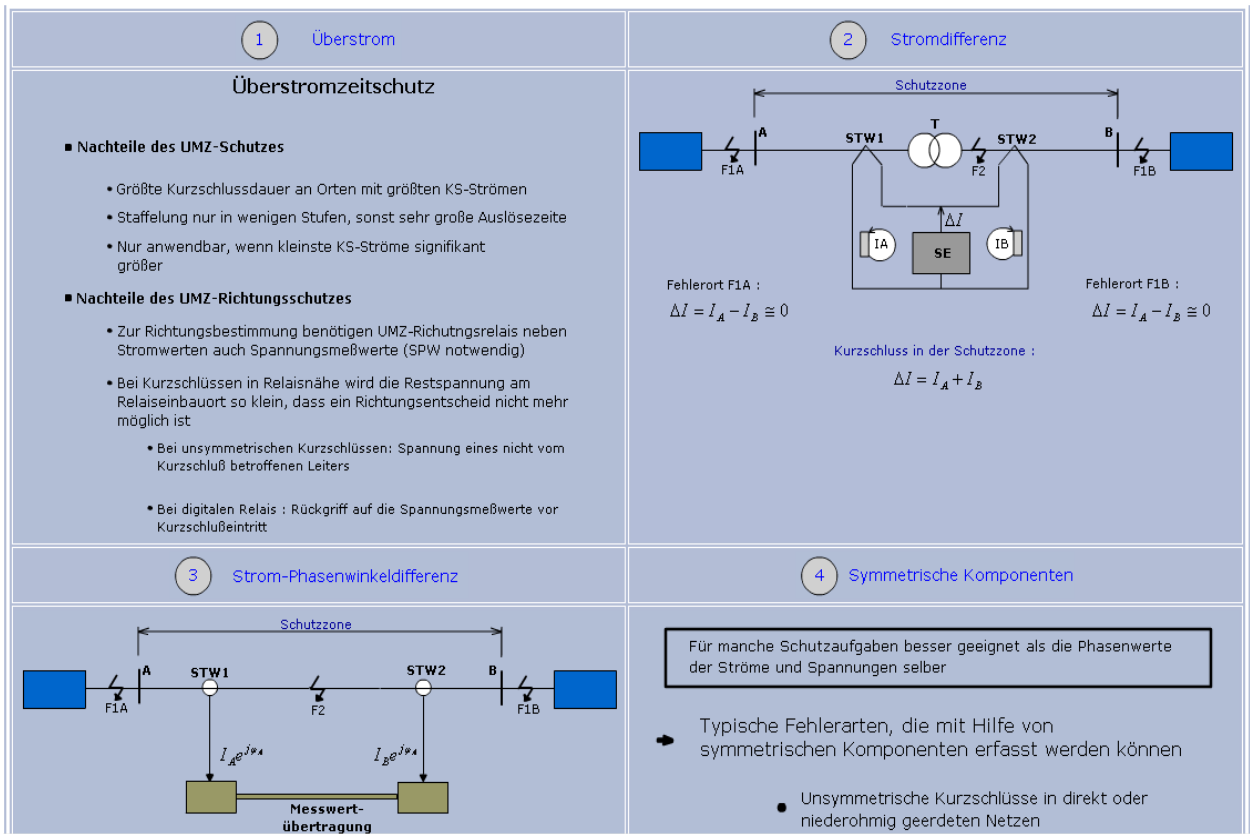

Fig. 7.3: Basic principles of the digital protection

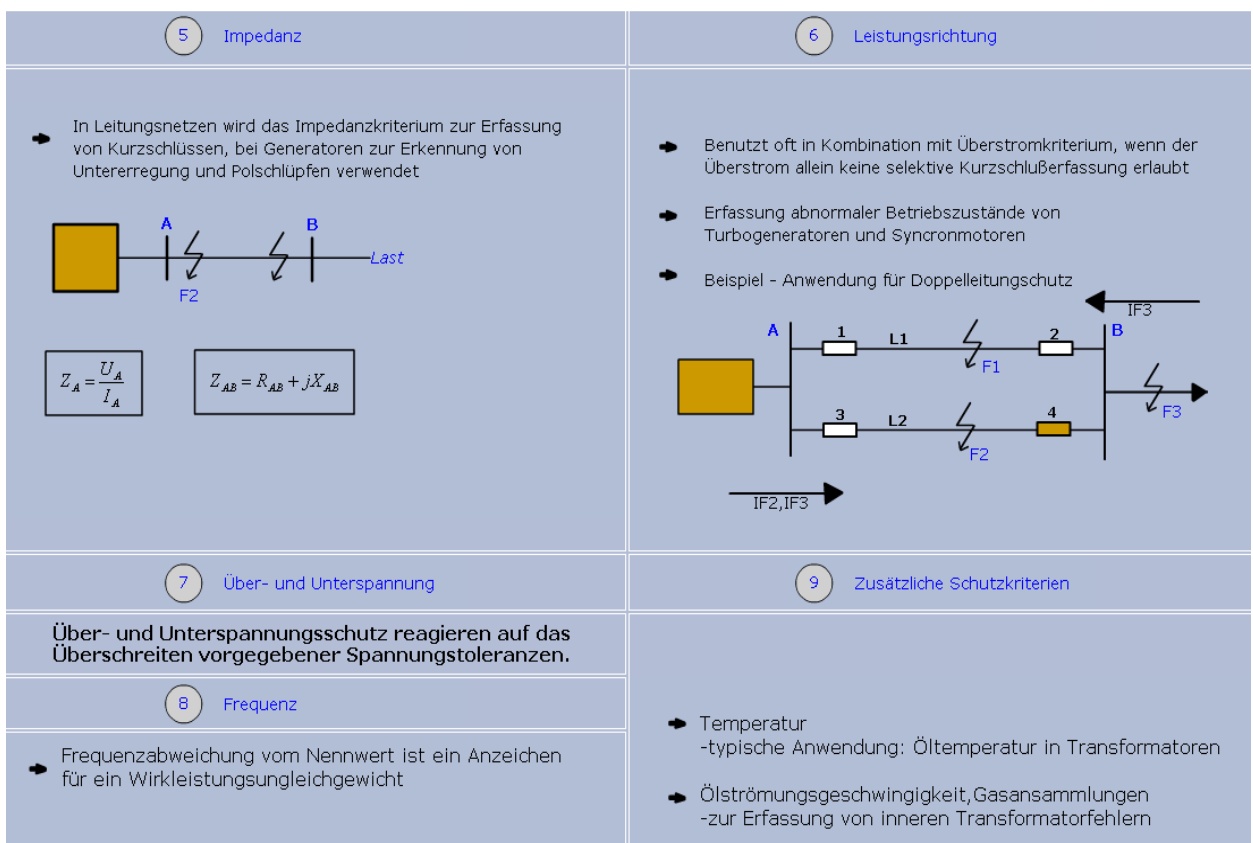

Fig. 7.4: Basic principles of the digital protection

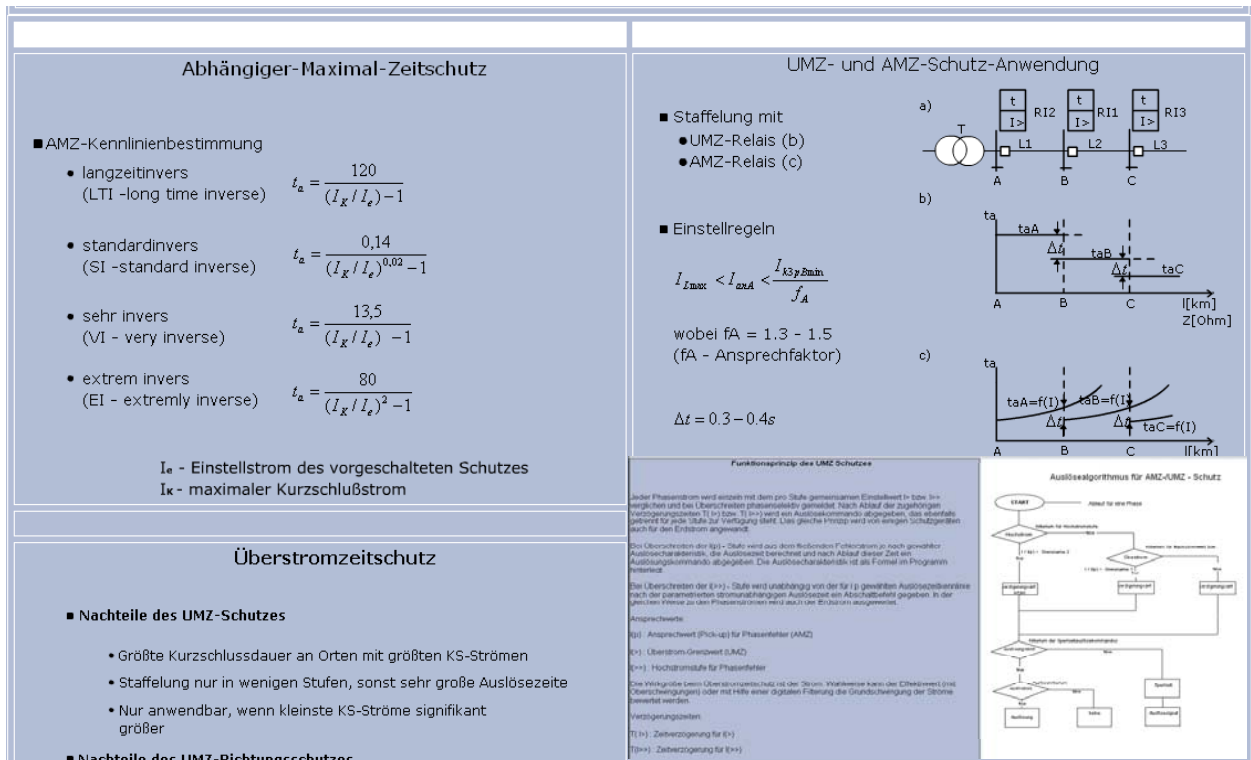

Fig. 7.5: Animated realisation of an over-current time dependent digital protection device

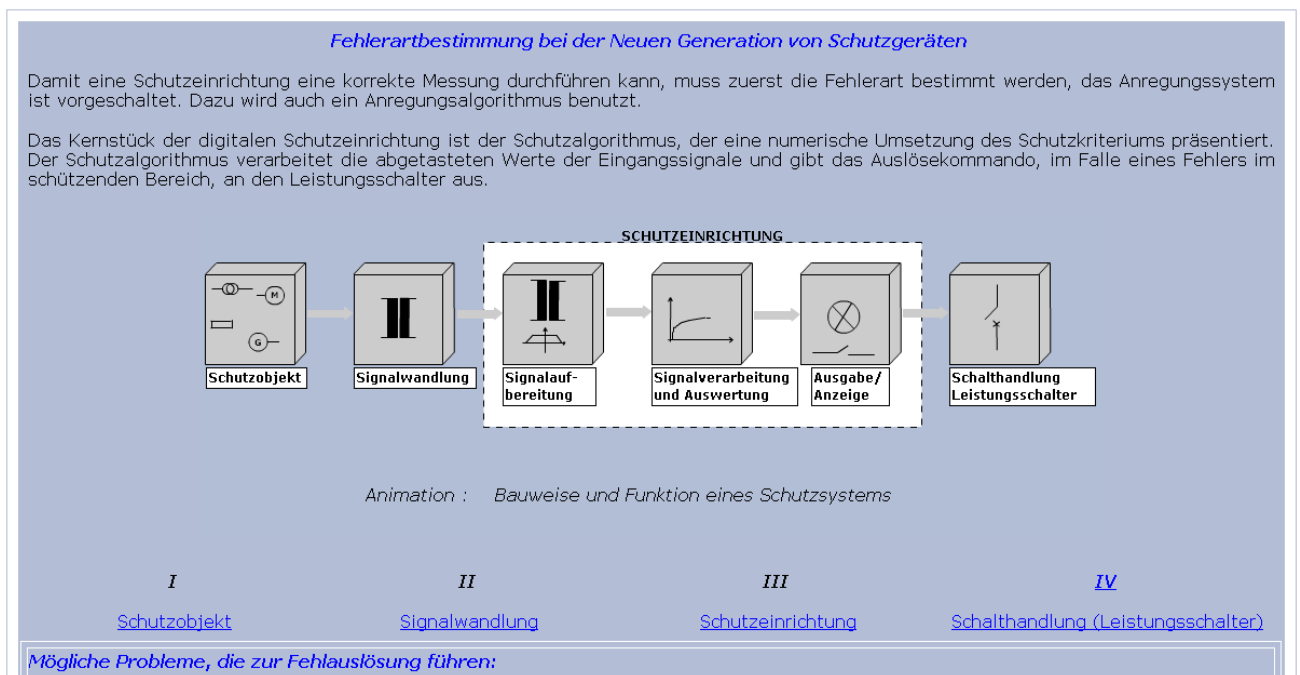
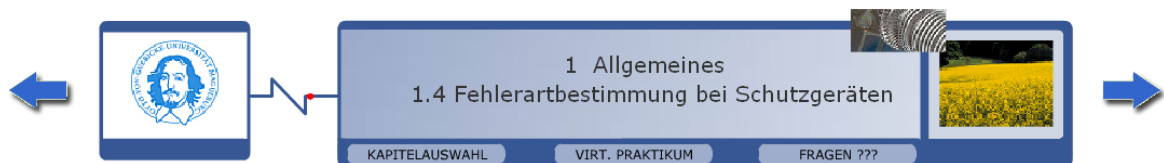

Fig. 7.6: Which elements contain the digital protection?

The chapter Differential Protection first provides a brief theoretical introduction providing explanations concerning the differential protection. In a few basic MATLAB examples the function of this type of protection is presented, and the implementation in the network is shown [76]. The application of the differential protection devices from the industry is also presented in a few examples, and with this the student receives information about the functional principle and application of this type of protection in the power system. The problems of current transformer saturation and their impact on the differential protection devices are also discussed in a few examples (Fig. 7.7).

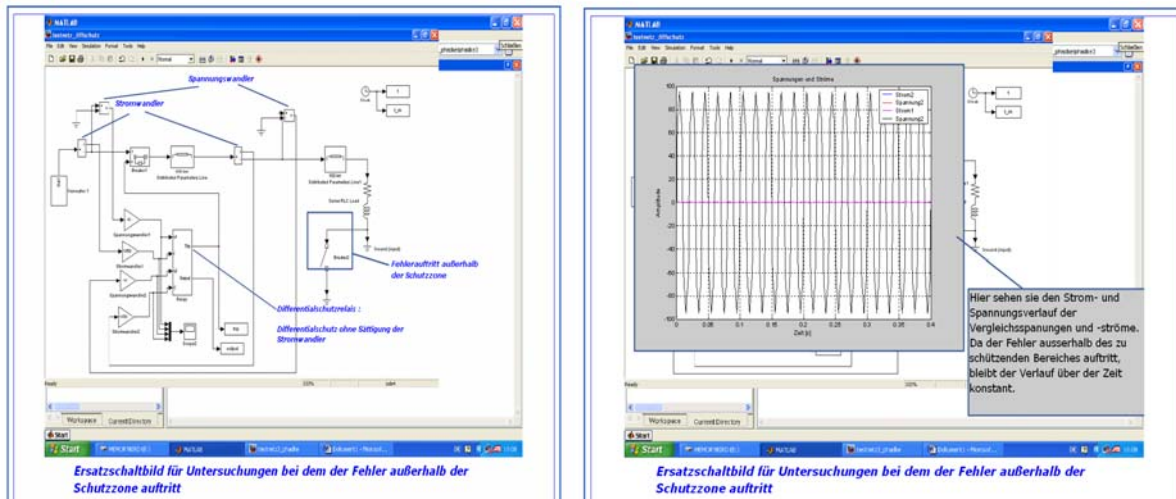

Fig. 7.7: Functional principle of differential protection

The chapter - Distance Protection – analyses the functional principles of different distance protection algorithms starting from the classical (differential equations, filters and stationary equations) to the new artificial methods - parameter estimation, harmonic activated neuronal networks – HANN, of impedance -distance to the fault- calculation. A few MATLAB examples of comparison between the algorithms in a sense of promptness and sensitivity are given [79]. In Fig. 7.8 the results of a MATLAB – simulation for the function of a digital distance protection device are presented. In this example the results of the algorithm of Phadke/Ibrahim are shown. This type of algorithm belongs to the group of so called filter algorithms. The calculation of the line parameters (impedance and angle) follows after the deviation of the complex values of

the measured signals of current and voltage. The principle of function of this algorithm as well as for the other types of algorithms is shown to the students in a step by step format. Fig. 7.8 presents an example where a single line fault (phase A) occurs at the moment $t = 0.2$ s and the algorithm gives the trip command to the circuit breaker after $t = 8$ ms. The student can choose between the different types of algorithms and study the differences and obtain conclusions by carrying out simulations under different fault conditions.

In the chapters - Over/Under Voltage Protection - and - Over/Under Frequency Protection - a few MATLAB examples show the implementation of these types of protection in the network. The functional principles and application are also presented.

Finally, the last chapter - "Picture of the Future" concerns the settings of the digital protection devices implemented in a distribution network with DER. A test distribution network with DER is chosen to illustrate the setting problems of the implemented network protection [80].

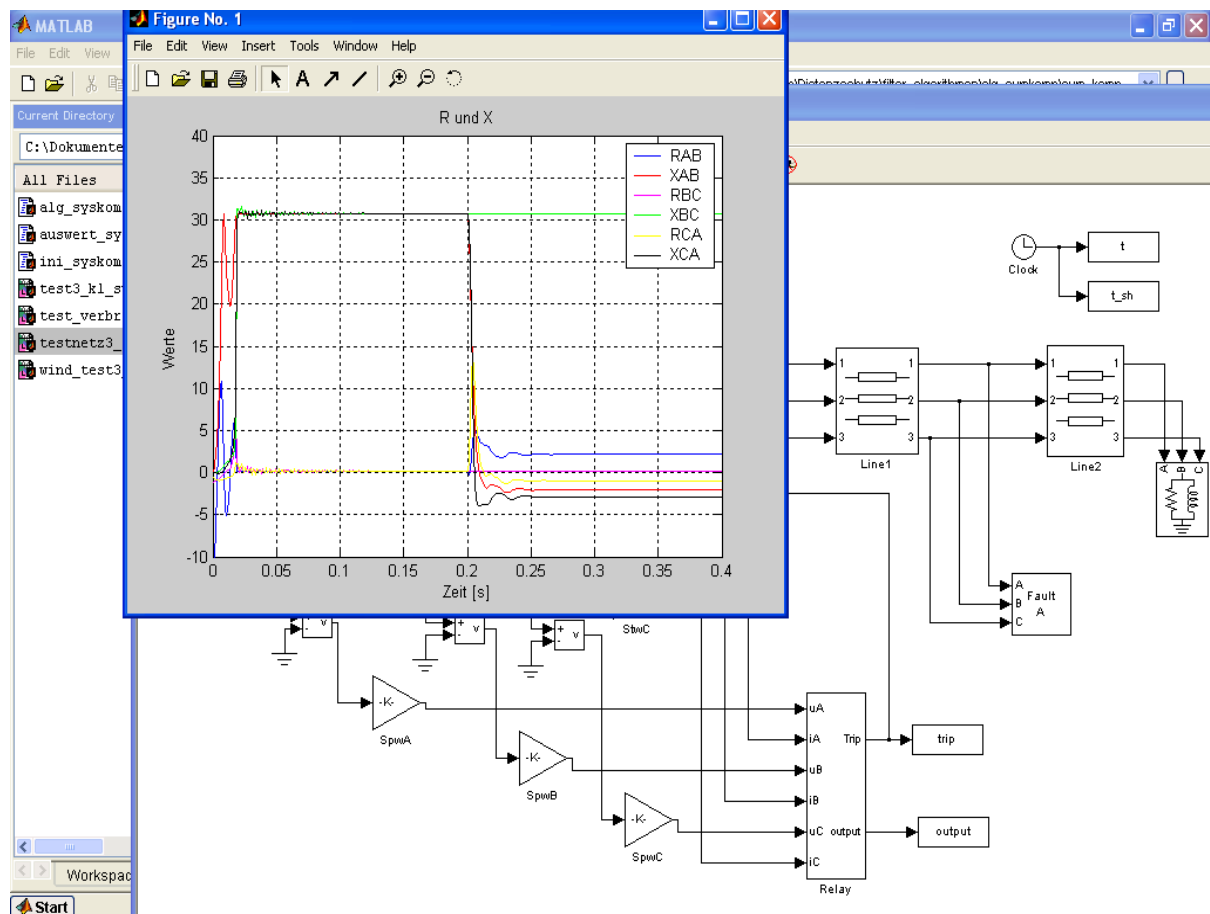

Fig. 7.8: MATLAB – Simulation: Distance protection

In this module a virtual practical exercise of three different protection devices is also implemented. The practical exercise is part of the lecture in the protection technique laboratory of the faculty. The student has the possibility to learn the use of the over-current, distance and differential protection devices, the construction of a tripping characteristic, as well as the response of the different protection devices under normal, overload and fault conditions. For teamwork among the students some virtual seminars are included. They are meant to occur at the end of the virtual lecture as a final report [83].

7.3 Results of implementation of e-learning system

In the multimedia laboratory 15 students were selected as a testing group for the module of digital protection. The students were of three different nationalities (German, Polish, Ukrainian) and between the ages of 22 and 27. Most of them (9) are studying in the master program offered at the university and the rest of them (6) are in the diploma program [83].

Nationality	Nr. of tested students	Age
German	6	1*22, 2*23, 3*25
Polish	4	1*22, 1*23, 2*24
Ukrainian	5	2*22, 3*23

Matter	Nr. of tested students
Previous Knowledge in the subject	1
Understanding the material	14

In the following table the number of students is listed considering the preferred type of studying (conventional or e-learning).

Matter	Conventional way of studying	e-learning	No answer/ both
Understanding the material	6	6	3
Clarity of the teaching material	1	10	4
Knowledge check up	2	10	3
Studying home	0	15	0
Possibility of communication during the studying (with lecturer or with other students)	11/9	4/3	0/3

In terms of the knowledge check-up the students wrote the following remarks:

They find a small test better in checking their knowledge and they see it as a preparation for the main exam. Some students (2, nat. Ukrainian) even prefer only on-line tests and exams. They also find the short test a very good opportunity to review what was taught on the day and in this way they see a possibility of studying better and faster.

Matter	Grade
Presentation of teaching material	6*A + 9*B
Presentation of tables	5*A + 10*B
Presentation of Animations	6*A + 9*B
Figure selection	2*A + 13*B
Graphics selection	8*A + 7*B
Overview of the teaching material	9*A + 6*B
Navigation realisation	7*A + 8*B

In terms of the preferred way of studying, below are some comments from the students:

- Some of the students (4, nat. German, Ukrainian and Polish) prefer the e-learning way of studying and they are willing to see it as a substitution of the conventional method of studying; They find this method of studying easier to understand and better than the conventional way of studying;
- Some of the students (5, nat. German, Ukrainian and Polish) prefer the conventional way of studying, but they do not mind using e-learning as a illustrative method for gaining more knowledge, or a possibility of re-caping. The main reason for this is that this group of students misses the lecturer and his/her explanation during the virtual studying (although there were some acoustic explanation implemented in the e-learning at the points we thought needed). Some students from this group prefer going to the library to get additional knowledge, rather than surfing on the web;

The rest of the students (6, nat. German, Ukrainian and Polish) see e-learning as an addition to the conventional way of studying, or studying at home and discussion with fellow students (who are also on-line). This group of students also prefers the possibility of using a PC during studying.

8. Conclusion

The continuously rising implementation of DER in the distribution network requests analyses of the present network protection concepts. Depending on the type of connection to the network, the influences of the DER on the network protection systems vary. This dissertation concentrates on the analyses of the influence of implementation of small DER, which are connected to the network via an inverter.

The first problem discussed in this dissertation is the influence of high level of harmonics on the protection devices. The rising implementation of power electronic devices into the network, both on the side of the energy generation and energy consumption, leads to a high level of injected harmonics into the network. The influence of a high amount of harmonics, according to the Standard IEC 61000-3-2, on different types of algorithms implemented in different types of protection devices was investigated using a test network. The tested algorithms implemented in the distance protection devices were based on conventional methods such as steady state algorithms, algorithms using the differential equation of first or second order written for the protected line, algorithms based on the filter approach, and on the "new" methods using artificial intelligence i.e.: parametrical estimation and harmonic activated neuronal networks. The different types of protection devices that were investigated were based on the principle of over-current (definite-current and inverse time), distance and differential. Some of the tests were conducted in the protection technique laboratory at the university. From both tests (simulation and practical) it is concluded that the state-of-the-art protection devices are insensitive to harmonics according to the allowed level by the standard IEC 61000-3-2. The tendency of today's protection technology engineers lies in searching for ways to shorten of the calculation time of the algorithms.

The second problem discussed is the challenge set to the network protection systems in the distribution networks with implemented DER. A few examples illustrate the situation of the energy supply of the future illustrate the problems of lack of protection with the present protection concepts. In this sense, this work presents and analyses a protection

concept in distribution networks with DER, using the substation automation system and the protection management system based on the new standard IEC 61850 for communication networks in substations. The method of using an additional signal injection as additional criteria for the presented network protection concept is also discussed.

The basis for efficient protection system management is the knowledge of power system performance under fault and normal operation (service) conditions as well as the switchgear interfaces. This requires a proper knowledge of power system engineering. With a changeable power system infrastructure, the protection system management becomes a real challenge to the network protection experts. Computer- and internet technology, modern serial communications, sharing of data with other disciplines and a trend towards system engineering require a broader knowledge and close co-operation with others, beside the protection system engineers.

With the goal of spreading the knowledge of network protection systems, in the frames of this work a special e-learning course was realised. The internet provides new possibilities for gaining and spreading knowledge. The time and place independence, the high amount of possibilities for knowledge sources and on line discussions are just a few of the possibilities. In this work, the idea, the realisation and the implementation of this new way of teaching and studying digital network protection alongside the conventional way are presented as well. An importance is also given to the feed back of the user of the e-learning course. This course is offered to the students at the university in a specially realised multimedia laboratory and used for gaining knowledge in the area of network protection technique. The possibility of using the course at home for re-capitulation of the taught material and for self-test is also possible, by simply logging on to the e-learning course. This course could also be used by engineers who want to refresh their knowledge in the form of a fast (self) training.

9. Zusammenfassung

Die stetig steigende Anbindung von dezentralen Energieerzeugern (DER) an Mittel- (MS) und Niederspannungsnetze (NS) fordert eine Analyse der bestehenden Netzschutzkonzepte. Die Beeinflussung der Netzschutzkonzepte ist abhängig davon, wie die DER an das Mittelspannungsnetz angebunden sind. Die vorliegende Arbeit konzentriert sich auf die Analyse von Beeinflussungen durch kleine DER, die an das Mittelspannungsnetz über einen Umrichter angebunden sind.

Das erste Problem, das in dieser Arbeit untersucht ist, ist die Beeinflussung der unterschiedlichen Schutzalgorithmen durch hohe Anteile von Harmonischen. Diese werden verursacht durch die steigende Zahl elektrischer Geräte, sowohl auf der Verbraucherseite als auch auf der Seite der Energieerzeuger. Die Beeinflussung, entsprechend der Norm IEC 61000-3-2, wurde an unterschiedlichen Typen von Netzschutzsystemen untersucht. Die getesteten Distanzschutzalgorithmen basierten auf konventionellen Methoden zur Berechnung der Impedanz wie: Sinus-Algorithmen, Algorithmen basierend auf der Leitungs-Differentialgleichung erster oder zweiter Ordnung, Filteralgorithmen für Berechnung komplexer Zeiger, und Algorithmen, die auf künstliche Intelligenz basieren, wie harmonisch aktivierte neuronale Netze. Die unterschiedlichen Typen von Netzschutzprinzipien, die untersucht wurden sind: Überstrom, Distanz und Differenzial. Einige Untersuchungen wurden auch im Netzschutzlabor der Universität durchgeführt. Bei beiden Tests konnte nachgewiesen werden, dass die heutigen state-of-the-art Netzschutzsysteme durch Harmonische entsprechend IEC 61000-3-2, praktisch nicht beeinflusst werden.

Der zweite Problembereich, der in dieser Arbeit diskutiert wird, sind die Anforderungen, welche die Anbindung von DER an das Netz, an moderne Netzschutzsysteme stellen. Einige Beispiele illustrieren die Lage der Energieversorgung der Zukunft und zeigen Selektivitätsprobleme auf, sollten nur konventionelle Netzschutzsysteme benutzt werden. In dieser Arbeit wird ein neues Schutzkonzept für Mittelspannungsnetze mit hohem Anteil an DER vorgestellt und analysiert. Das Konzept beruht auf der neuen Norm für „Substation Automation System - IEC 61850“ und einem Netzschutz-Managementsystem. Die Methode der zusätzlichen Signal-Einspeisung wurde ebenfalls vorgestellt.

Die Basis eines effizienten Netzschutz-Managementsystems ist das Wissen vom Verhalten des Systems in normalen Betrieb und unter Fehlerbedingungen. Die Computer- und Internettechnologie, die moderne Kommunikation, der interdisziplinäre Datenaustausch stellen ganz neue Anforderungen an die Wissensbasis energietechnischer Ingenieure.

Mit dem Ziel neue Medien in der Ingenieurausbildung einzusetzen ist, im Rahmen dieser Arbeit ein E-learning Kurs entwickelt worden. Dabei ermöglicht das Internet neue Methoden zur Wissensvermittlung zu entwickeln. Die Unabhängigkeit von Zeit und Ort, die große Anzahl von Lernmöglichkeiten und die Online-Diskussionen sind nur einige zu nennende Vorteile. In dieser Arbeit ist die Idee zur Realisierung sowie Ergebnisse des E-learning Kurses im Bereich digitaler Netzschutztechnik, als Erweiterung der konventionellen Lehrveranstaltung präsentiert worden. Dieser Kurs wird den Studenten der Universität in einem speziell gestalteten Multimedialabor angeboten. Es besteht via Internet die Möglichkeit den Kurses z.B. zu Hause zur Wiederholung und Prüfungsvorbereitung nochmals zu bearbeiten.

10. Literature

- [1] J. M. Gers and E. J. Holmes. Protection of Electricity Distribution Networks. IEE Power & Energy Series 47. 2003. ISBN 0-86341-357-9.
- [2] H. Clemens and K. Rothe. Schutztechnik in Elektroenergiesystemen. Technik Verlag. 1991. Auflage 5. ISBN 3-341-00828-4.
- [3] W. Doemeland. Handbuch Schutztechnik. Technik Verlag. 1995. ISBN 3-341-01093-9.
- [4] H. Ungrad, W. Winkler and A. Wiszniewski. Schutztechnik in Elektroenergiesystemen. Grundlagen, Stand der Technik, Neuentwicklungen. Springer Verlag. 1991.
- [5] H.-J. Herrmann. Digitale Schutztechnik. Grundlagen, Software, Ausführungsbeispiele. VDE-Verlag. 1997. ISBN 3-8007-1850-2.
- [6] A.G. Phadke and J.S. Thorp. Computer Relaying for Power Systems. Research Studies Press, Ltd., 1988.
- [7] K. M. Jensen and H. Lipken. Verhalten von Stromwandlern für Meßzwecke bei Überströmen. Elektrizitätswirtschaft. Jg. 78. Heft 17. 1979.
- [8] H.-J. Herrmann. Digitale Schutztechnik im Elektroenergiesystem – Algorithmen für den Staffelschutz. Elektrie. Berlin 44. Heft 3. 1990.
- [9] H.-J. Herrmann. Digitaler Überstromzeit- und Distanzschutz. Elektrie. Berlin 44. 1990.
- [10] G. Hosemann and H. M. Steigerwald. Modal Saturation Detection for Digital Differential Protection. IEEE Transactions on Power Delivery. Vol.8. No.3. 1993. pp. 245-151.
- [11] H.-J. Herrmann. Entwurf digitaler Schutzeinrichtungen unter Berücksichtigung der Stromwandlersättigung. Elektrie. Berlin 56. 2002. pp. 9-12.
- [12] D. Tziouvaras, P. McLaren, C. Alexander, D. Dawson, J. Esztergalyos, C. Fromen, M. Glinkowski, I. Hasenwinkle, M. Kezunovic, L. Kojovic, B. Kotheimer, R. Ruffel, J. Nordstrom, S. Zochol, Mathematical Models for Current, Voltage and Coupling Capacitor Voltage Transformers, IEEE Transactions on Power Delivery Vol. 15. No. 1. 2000. pp. 62-72.

- [13] A. Kloss. Netzurückwirkungen der Leistungselektronik. VDE Verlag. Berlin. 1996. ISBN 3800721570.
- [14] R. Krebs. Analysis Anisotropien dreiphasiger Betriebsmittel. Ph.D. Dissertation. Technical Dept. University Erlangen Nuernberg. 1990.
- [15] M. Kezunovic, I. Rikalo, "Automating the Analysis of Faults and Power Quality," IEEE Computer Applications in Power Vol. 12. No. 1. 1999. pp. 46-50.
- [16] H. Nelles and H. Opperskalski. Digitaler Distanzschutz. Verhalten der Algorithmen bei nichtidealen Eingangssignalen. Dt. Univ.-Verl. 1991. ISBN 3-8244-2022-8.
- [17] M. Kezunovic, "A Survey of Neural Net Applications to Protective Relaying and Fault Analysis," Engineering Intelligent Systems Vol. 5. No. 4. 1997. pp. 185-192.
- [18] B. Hadzi-Kostova, J. Haubrock, Z. Styczynski: Investigation of the Influence of Non-sinusoidal Currents and Voltages on the Digital Distance Protection. 4th Balkan Power Conference. Sarajevo, Bosnia and Herzegovina. 2004. pp. 185-190.
- [19] B. Hadzi-Kostova, Z. Styczynski: A Comparison of Distance Protection Algorithms in Distribution System with High Level of Harmonics, CRIS. Grenoble, France. 2004. Section 5 Paper 3.
- [20] P.G. McLaren, C. Henville, V. Skendzic, A. Girgis, M. Sachdev, G. Benmouyal, K. Mustaphi, M. Kezunovic, Lj. Kojovic, M. Meisinger, C. Simon, T. Sidhu, R. Marttila, D. Tziouvaras, "Software Models for Relays," IEEE Transaction on Power Delivery Vol. 16. No. 2. 2001. pp. 238-246.
- [21] T. Sequi, P. Bertrand, M. Guillot, P. Hanchin, P. Bastard. Fundamental Basis for Distance Relaying with Parametrical Estimation. IEEE Transactions on Power Delivery. Vol. 15. No.2. 2000. pp. 345-349.
- [22] F. Zahra, B. Jeyasurya, J. E. Quaicoe. High-speed transmission line relaying using artificial neural networks. Electric Power Systems Research 53. 2000. pp. 173-179.
- [23] T. Lobos, Z. Leonowicz, J. Rezemer and J. Koglin. Advanced signal processing methods of harmonics and interharmonics estimation. 7th International Conference on Developments in Power System Protection. 2001. pp. 315-318.

- [24] M. Kezunovic, "A Survey of Neural Net Applications to Protective Relaying and Fault Analysis," *Engineering Intelligent Systems* Vol. 5. No. 4. 1997. pp. 185-192.
- [25] Z. M. Radojevic, V. V. Terzija and M. B. Djuric. Numerical Algorithm for Overhead Lines Arcing Faults Detection and Distance and Directional Protection. *IEEE Transactions on Power Delivery*. Vol.15. No.1. 2000. pp. 156-162.
- [26] A. Abur, M. Kezunovic, "A Simulation and Testing Laboratory for Addressing Power Quality Issues in Power System," *IEEE Transactions on Power Systems* Vol. 14. No.1. 1999. pp. 3-8.
- [27] Bundesministerium für Wirtschaft und Technologie. Nachhaltige Energiepolitik für eine zukunftsfähige Energieversorgung. 2001.
- [28] Bundesministerium für Umwelt, Naturschutz und Reaktorsicherheit. Erneuerbare Energien und nachhaltige Entwicklung. 2000.
- [29] S. A. Hallij. More then Enviro-friendly. *IEEE Power & Energy Magazine*. Vol. 2. No. 3. 2004. pp. 16-22.
- [30] R. C. Sonderregger, D. Henderson, S. Bubb and J. Steury. Distributed Asset Insight. *IEEE Power & Energy Magazine*. Vol. 2. Nr. 3. 2004. pp. 32-39.
- [31] K. Voges and D. Povh. Power Transmission in the Coming Century. Cigre Reginal Meeting South Asia and Westren Pacific. Melbourne. 1997.
- [32] M. A. Redfern and Ö. Usta. A new Microprocessor Based Islanding Protection Algorithm for Dispersed Storage and Generation Units. *IEEE Transactions on Power Delivery* Vol. 10. No. 3. 1995. pp. 134-140.
- [33] P. L. Villeneuve. Concerns Generated by Islanding. *IEEE Power & Energy Magazine*. Vol. 2. Nr. 3. 2004. pp. 49-53.
- [34] G. Potamianakis and C. D. Vournas. Aggregation of Wind farms in Distribution Networks. European Wind Energy Conference and Exhibition. Madrid. 2003.
- [35] R. Klosse, F. Santjer and G. Gerdes. Elektrische Netzschutztechnik an Windenergieanlagen. *DEWI Magazin* Nr. 13. 1998.
- [36] S. J. Haslam, P. A. Crossley, N. Jenkins, M. Burt and A. Borrill. Design and Evaluation of a New Type of Protection for Wind Farms. *Developments in Power System Protection*. 1997. Conference

Publication No. 434.

- [37] P. P. Barker and B. K. Johnson. Power System Modelling Requirements for Rotating Machine Interfaced Distributed Resources. IEEE Transactions on Power Delivery. Vol. 5. No. 5. 2002. pp. 123-129.
- [38] W. Novak and G. Koch. New system protection requirements in de-regulated markets. PSP 2004. pp. 34-41.
- [39] S. K. Salman and I. M. Rida. Investigating the Impact of Embedded Generation on Relay Settings of Utilities' Electrical Feeders. IEEE Transactions on Power Delivery. Vol. 16. No. 2. 2001. pp. 272-279.
- [40] R. Bitsch, W. Feldmann and G. Aumayr. Virtuelle Kraftwerke – Einbindung dezentraler Energieerzeugungsanlagen. ETZ. Heft 9/2002.
- [41] B. Hadzi-Kostova, Z. Styczynski: Challenges Set to the Digital Protection with Implementation of Dispersed Energy Resources on the Network. IV Mako CIGRE. 2004. Section C6-03.
- [42] B. Hadzi-Kostova, Z. Styczynski: Identification of Problems by Connecting Decentralised Energy Resources on the Distribution Network. IV Mako CIGRE. 2004. Section B5-05.
- [43] B. Hadzi-Kostova, Z. Styczynski: Investigation of the influence of integrated dispersed energy resources and on non-linear loads on the digital protection, ETAI, VI National Conference. Ohrid, R. Macedonia, Section H5. 2003. pp. 1-6.
- [44] J. Motohashi, K. Taguchi, T. Takano, M. Watanabe and K. Ogawa. Development of Advanced Systems Corresponding to the Connection of Dispersed Generation to Distribution System in Tokyo Electric Power Company. CIGRE 2004. Paper C6-109
- [45] D. Tholomier, R. Rallain, H. Grasset and A. Perks. The Challenges Met During Protection Relay Certification. CIGRE 2004. Paper B5-206.
- [46] N. Lahner, S. Csontos, S. Chari and W. Baass. Incremental implementation of utility-wide protection information system. CIGRE 2004. Paper B5-104.
- [47] S. Gal, F. Balasiu and N. Chiosa. Protection System Database. CIGRE 2004. Paper B5-207.
- [48] B. Min, S. Lee, M. Choi, S. Kang, S. Hyun, H. Kim, J. Roh and J.

- Hong. Automated Relay Setting and Protection Database Management System. CIGRE 2004. Paper B5-208.
- [49] K. Brand, C. Brunner and W. Wimmer. Design of IEC 61850 Based Substation Automation Systems According to Customer Requirements. CIGRE 2004. Paper B5-103.
- [50] Z. Shukri, A. Zin and K. Lo. Integrating Protection Engineering and Management Tools for Utility Practices. CIGRE 2004. Paper B5-209.
- [51] M. Kezunovic, T. Popovic, D. Sevcik and A. Chitambar. Automated Fault Analysis Using Advanced Information Technology for Data Integration and Information Exchange. CIGRE 2004. Paper B5-102.
- [52] F. Hohlbaum, L. Hossenlopp and G. Wong. Concept and First Implementation of IEC 61850. CIGRE 2004. Paper B5-110.
- [53] R. Subramanian and H. Hosani. Substation Control System-Present Practices and Future Trends. CIGRE 2004. Paper B5-101.
- [54] B. Deck and M. Naedele. IT Security for Utility Automation Systems. CIGRE 2004. Paper B5-105.
- [55] K. Uhlen, L. Warland, J. Gjerde, K. Vu and O. Kirkeluten. Concepts for Intelligent monitoring and Control of Power Grids by Use of New Measurement Technologies. CIGRE 2004. Paper B5-109.
- [56] V. Thong, D. Dommelen, J. Driesen and R. Belmans. Impact of Large Scale Distributed and Unpredictable Generation on Voltage and Angle Stability of Transmission System. CIGRE 2004. Paper C6-205.
- [57] J. Curk, I. Kobal and G. Parkelj. Modern IT Technology Improves Substation Control and Protection Systems Architecture. Power System Protection Conference. Bled. 2004. pp. 41-45.
- [58] K.P. Brand and B. Buchholz. System requirements ensuring interoperability in the substation automation. ETZ, 2004.
- [59] P. McGuire, D. MacGregor, A. Guiliante, R. Patterson and G. Holt. Automated Setting of Relays for Transmission Line Pilot Protection. Paper B5-202, CIGRE 2004.
- [60] A.P. Apostolov. Distributed Protection, Control and Recording in IEC 61850 Based Substation Automation Systems. APAP Korea 2004. pp. 41-46.
- [61] C. Hoga, H. Schubert, G. Wong and G. Kissling. Securing the Future

- of Substation Automation with IEC 61850. APAP Korea 2004. pp. 47-52.
- [62] T. Kato, H. Kanamori, K. Okuyama, Y. Suzuoki, Y. Kawasaki and T. Funabashi. Conceptual Study on a New Protection Schema Based on Information Technologies for Distribution System with High Penetration of Distributed Generators. APAP Korea 2004. pp. 84-89.
- [63] J. Jäger, L. Shang and R. Krebs. New Overcurrent Protection Characteristics for a Time Optimised Selective Grading under Consideration of Networks with Distributed Generation. APAP Korea 2004. pp. 90-93.
- [64] S. Kim, K. Kim, S. Jang and J. Choi. Advanced Protective Functions for grid Connected Distributed Generations. APAP Korea 2004. pp. 457-461.
- [65] A.P. Apostolov. Application of Peer-to-Peer Communication for Protective Relaying. IEEE Transactions on Power Delivery. Vol.17. No.2. 2002. pp. 123-129.
- [66] M. Kezunovic, A. Abur, A. Edris and D. Sobajic. Data Integration/Exchange. IEEE Power & Energy Magazine. Volume 2. Nr. 3. May/June 2004. pp. 24-29.
- [67] M. Gilany. A New System Technique for Backup Protective Relays. 14th International Conference on Power System Protection. Bled, Slovenia. 2004. pp. 187-191.
- [68] B. Hadzi-Kostova, Z. Styczynski and R. Krebs. New Protection Concepts for Distribution Systems with Distributed Generation. PowerTech, St. Petersburg, Russia (in Press) 2005.
- [69] B. Hadzi-Kostova and Z. Styczynski. Network Protection in Distribution Systems with Distributed Generation. New Orleans, USA. (in Press) 2005.
- [70] K.P. Brand and W. Wimmer. Der Standard IEC 61850, offene Kommunikation in Schaltanlagen im deregulierten Strommarkt. Bulletin SEV/VSE. Nr. 1. 2002.
- [71] Verband der Netzbetreiber-VDN beim VDEW. IEC 61850 – Anforderungen aus Anwendersicht. www.vdn-berlin.de. Ausgabe: 2004.
- [72] M. Kezunovic, T. Djokic and T. Kostic. Automated Monitoring and Control Using New Data Integartion Paradigm. International

Conference on Systems Science. 2005.

- [73] M. Kezunovic. Data Integration and Information Exchange for Enhanced Control and Protection of Power Systems. International Conference on Systems Science. 2003.
- [74] H. T. Roman. Reengineering Education. IEEE Power & Energy Magazine. Vol. 2. No. 3. 2004. pp. 85-88.
- [75] M. Kezunovic, A. Abur, G. Huang, A. Bose, K. Tomsovic, "The Role of Digital Modeling and Simulation in Power Engineering Education," IEEE Transactions on Power Delivery Vol. 19, No.1. 2004. pp 64-72.
- [76] M. Kezunovic, "An Advanced Approach to Teaching Protective Relaying Courses," Intl. Journal of Electrical Engineering Education Vol. 28, No. 3. 1991.
- [77] M. Kezunovic. User-Friendly, Open-System Software for Teaching Protective Relaying Application and Design Concepts. IEEE Transactions on Power Systems. Vol. 18, No. 3, 2003. pp. 986–992.
- [78] B. Hadzi-Kostova. Multimedialer Lernprozess mit Wissenskontrolle regenerative Energie für das Fachstudium der Studenten des Landes Sachsen-Anhalt, IV Dresdener Kreis. Hannover, 2003. pp. 99-107.
- [79] B. Hadzi-Kostova. Multimedia in der Lehre - Regenerative Energieerzeugung – RegEn–M, V Dresdener Kreis, 2004.
- [80] B. Hadzi-Kostova, Z. Styczynski and R. Krebs. Teaching Digital Network Protection Using E-Learning System, 14th International Conference on Power System Protection. Bled, Slovenia. 2004. pp. 249-254.
- [81] B. Hadzi-Kostova, J. Haubrock, A. Lebioda, A. Orths and Z. Styczynski. Teaching Renewable Energy Using E-Learning System RegEn–M (Renewable Energy Multimedial). ED-MEDIA, Lugano, Switzerland. 2004. pp. 1791-1795.
- [82] B. Hadzi-Kostova and Z. Styczynski. Teaching Renewable Energy Using Multimedia, PSCE, New York, USA. 2004.
- [83] B. Hadzi-Kostova and Z. Styczynski. Network Protection in Distribution Systems with DER, Wroclaw, Poland, V Conference on Distributed Power Networks. 2004. pp. 199 – 204.

- [84] B. Hadzi-Kostova and Z. Styczynski. Teaching Water Power Plants Using an E-learning System. PowerTech. St. Petersburg, Russia, (in Press) 2005.
- [85] A. Angelov, J. Haubrock, B. Hadzi-Kostova and Z. Styczynski. Teaching Renewable Using VRML-Technology. PowerTech, St. Petersburg, Russia, (in Press) 2005.
- [86] M. Purmann. Optimierung des Betriebsverhaltens von PEM-Brennstoffzellen unter Berücksichtigung von elektrischem und Gesamtwirkungsgrad bei unterschiedlichen Lastanforderungen und Betriebsparametern. 2004. ISBN 3-929757-63-X.
- [87] R. Krebs and O. Ruhle. NETOMAC Real-Time Simulator – Standard Test Modules for Enhanced Relay Testing 14th International Conference on Power System Protection. Bled, Slovenia. 2004.
- [88] R. Krebs and R. Ganjavi. How to Provide Selective Protection in Current Limited Power Systems. 3rd International Conference on Power System Protection and Automation. Delhi, India. 2004.
- [89] G. Benmouyal, E. O. Schweitzer and A. Guzman. Synchronized phasor measurement in protective relays for protection, control and analysis of electric power systems. 29th Annual Western Protective Relay Conference. Washington, USA. 2002.
- [90] C. Rehtanz and J. Bertsch. Wide Area Measurement and Protection System for Emergency Voltage Stability Control. Available at: <http://www.eeh.ee.ethz.ch/psl/publications/papers.html>
- [91] M. Zima. Special Protection Schemes in Electric Power Systems. Literature survey. ETH Zürich. 2002. Available at: <http://www.eeh.ee.ethz.ch/psl/publications/papers.html>
- [92] M. Larsson, C. Rehtanz and J. Bertsch. Real-Time Voltage Stability Assesment of Transmisson Corridors. Available at: <http://www.eeh.ee.ethz.ch/psl/publications/papers.html>
- [93] J. Bertsch, M. Zima, A. Suranyi, C. Carnal, C. Rehtanz and M. Larsson. Experiences with and Perspectives of the System for Wide Area Monitoring of Power Systems. CIGRE/IEEE-PES International Syposium Quality and Security of Electric Power Systems. Montreal, Canada. 2003.
- [94] C. Rehtanz, M. Larsson, M. Zima, M. Kaba and J. Bertsch. System for Wide Area Protection, Control and Optimization based on Phasor Measurements. Power Systems and Communication System Infrastructures for the Future. Beijing, China. 2002.

- [95] M. Larsson, R. Gardner and C. Rehtanz. Interactive Simulation and Visualisation of Wide Area Monitoring and Control Applications. Available at: <http://www.eeh.ee.ethz.ch/psl/publications/papers.html>. 2002
- [96] C. Martinez, M. Parashar and J. Dyer: Phasor Data Requirements. EIPP – Real Time Task Team. 2004.
- [97] C. Rehtanz and D. Westermann. Wide Area Measurement and Control System for Increasing Transmission Capacity in Deregulated Energy Markets. 14th PSCC. Sevilla, Spain. 2002.
- [98] M. Geidl. Protection of Power Systems with Distributed Generation Available at: <http://e-collection.ethbib.ethz.ch/>. 2005.
- [99] EPRI Section 9. Distributed Generation Modeling Guidelines. Available at: http://www.disgen.com/downloads/09-DGModelingGuidelines_Revised.PDF 2005.

During my work as an assistant at LENA I have supervised the following diploma theses and independent study- and semester- projects.

Diploma works

- [1] J. Haubrock: Entwicklung und Realisierung einer webbasierten Lehrveranstaltung im Fach Alternative Energiequellen für Studenten des Landes Sachsen-Anhalt (Module Wind als Energiequelle und Brennstoffzelle). April 2004.
- [2] A. Angelov: Entwicklung und Realisierung einer webbasierten Lehrveranstaltung im Fach Alternative Energiequellen für Studenten des Landes Sachsen-Anhalt (Module Photovoltaik und Allgemeine Grundlagen der dezentralen Energieerzeugung). April 2004.
- [3] K. Ivanyshyna: Wirtschaftspolitische Optionen für dezentrale Energieerzeugern. Oktober 2005.
- [4] M. Loerke: Entwicklung und Realisierung einer webbasierten Lehrveranstaltung im Fach Netzschutztechnik für Studenten des Landes Sachsen-Anhalt. Oktober 2005.
- [5] M. Netzband: Untersuchung der Änderung der Sternpunktbehandlung auf das Netzschutzkonzept. Oktober 2005.

Independent study– and semester projects

- [1] M. Loerke: Entwicklung und Realisierung einer webbasierten Lehrveranstaltung im Fach Netzschutztechnik für Studenten des Landes Sachsen-Anhalt. Juli 2004.
- [2] M. Netzband: Aufbau und Inbetriebnahme eines Netzschutzversuchsstandes mit modernen Schutzgeräten zur Durchführung von Laborpraktika. Juli 2004.
- [3] M. Käbisch: Aufbau und Inbetriebnahme einer Wetterstation, Messungsdurchführung, Übertragung den Messdaten und Bearbeitung der Messwerte. August 2004.
- [4] N. Schäfer: Entwicklung und Realisierung einer webbasierten Lehrveranstaltung im Fach Alternative Elektroenergiequellen für Studenten des Landes Sachsen-Anhalt (Modul Wasserkraft als Energiequelle). August 2004.
- [5] J. Haubrock: Untersuchung der Beeinflussung des Distanzschutzes von Harmonischen. April 2003.

Published MaFo Books

- [1] **A. Orths:** Multikriterielle, optimale Planung von Verteilungsnetzen im liberalisierten Energiemarkt unter Verwendung von spieltheoretischen Verfahren. ISBN: 3-929757-57-5.
- [2] **M. Purmann:** Optimierung des Betriebsverhaltens von PEM-Brennstoffzellen unter Berücksichtigung von elektrischem und Gesamt-vwirkungsgang bei unterschiedlichen Lastanforderungen und Betriebsparametern. ISBN: 3-929757-63-6.
- [3] **M. Al-Hamid:** Extraktion von höheren Moden TEM-Wellenleitern. ISBN: 3-929757-64-8.
- [4] **H. Haase, J. Nitsch, T. Steinmetz:** Transmission-Line Super Theory - A new Approach to an Effective Calculation of Electromagnetic Interference. ISBN: 3-929757-67-2.
- [5] **A. Bachry:** Power Quality Studies in Distribution Systems Involving Spectral Decomposition. ISBN: 3-929757-68-0.
- [6] **Z. Styczynski:** Power Network and Renewables - A Scientific Report- (5 Years Research). ISBN: 3-929757-69-9.
- [7] **E. Blume:** Numerische Analyse der Kopplung linearer Antennen innerhalb eines Resonators. ISBN: 3-929757-71-0.
- [8] **E. Handschin, Z. Styczynski:** Power System Application of the Modern Battery Storage. ISBN: 3-929757-75-3.
- [9] **H. Haase:** Full-Wave Field Interactions of Nonuniform Transmission Lines. ISBN: 3-929757-78-8.
- [10] **D. Nitsch:** Die Wirkung eingekoppelter ultrabreitbandiger elektromagnetischer Impulse auf komplexe elektronische Systeme. ISBN: 3-929757-79-6.